

# LEMO's Environmentally Sealed Connectors ●

K Series - Mechanical Keying

E Series - Hermaphroditic Keying

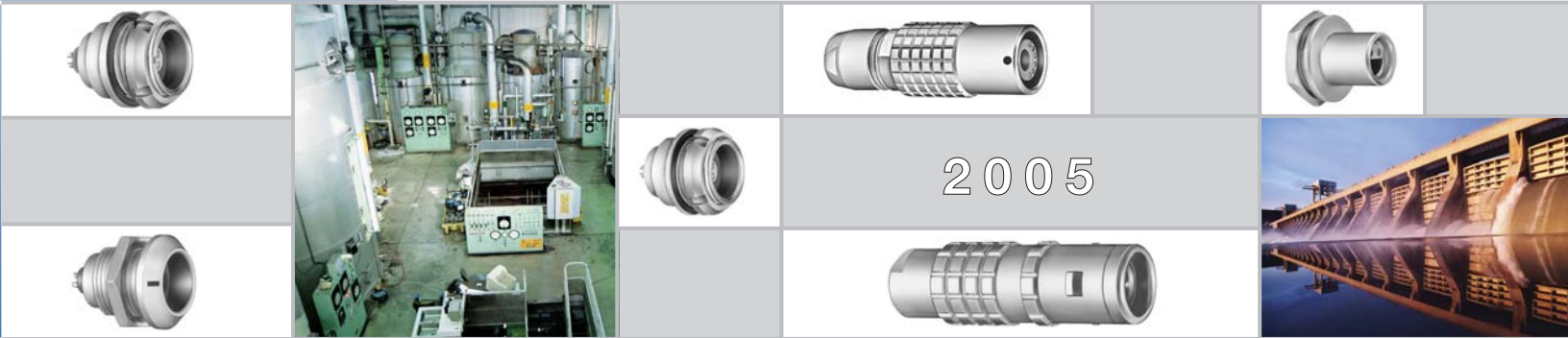

2005



**LEMO**

# Expect Success. Spec LEMO®



## • A Global Leader

Since its beginning in Switzerland in 1946, LEMO® has evolved into a worldwide leader in the design and manufacture of circular connectors, with products sold in more than 80 countries.

Today, LEMO offers a product line for almost any application, from medical equipment to test and measurement instrumentation.

## • LEMO Means "Quality"

The name LEMO has become synonymous with quality and customer service in the connector industry, setting standards that others strive to meet. Our connectors are designed in an ISO 9001 business environment, ensuring the highest quality products for our customers.

## • LEMO – We Deliver Reliability

Ask for LEMO connectors for any application where quality, safety and ruggedness are essential; where reliability is critical or where connectors are frequently engaged and disengaged, even in the toughest environments.

LEMO Connectors offer a unique combination of benefits:

**Original QUICK-LOK™** push-pull, self-latching system saves space and time while ensuring durable connections.

**Precision construction** from machined brass, stainless steel or aluminum ensures safety and uniform mating.

**Gold plated contacts** assure excellent electrical performance.

**Collet-type strain relief** securely grips circumference of any round cable, protecting connection even under extreme stress.

**Bend relief option** offers additional cable protection, including color-coding for easy identification.



## Custom Design

If we don't have it, we'll build it. Although we offer the most extensive product line in the industry, we understand that some application needs are unique. If we don't have exactly what you need, LEMO will design and build a connector that's just right for your application.

## Cable Assembly

Expand the quality of the connector to the cable assembly with our one-stop shop value-added service. LEMO's skilled technicians build and test assemblies to your specifications.

## Customer Support

Customer Support when you need it. Only LEMO offers extended customer service hours so you get technical support when you need it. LEMO's Customer Support Team includes in-house Product Specialists, plus a nationwide network of sales representatives and distributors.



**LEMO®**

## ● Table of Contents

<b>General Information</b>	LEMO's Product Line .....2 Characteristics of Primary Series .....2 LEMO's Line of Series by Types .....3 QUICK-LOK™ Push-Pull Self-Locking System ...4
<b>General Characteristics</b>	Outer Shell, Technical Characteristics .....5 Electrical Characteristics .....6 Insulator, Technical Characteristics .....7 Electrical Contact .....8
<b>K Series Connectors</b>	Introduction .....14 Interconnections .....14 Part Section Showing Internal Components .....15 Part Number Example .....17 Models .....18 Types .....27
<b>E Series Connectors</b>	Introduction .....44 Interconnections .....44 Part Section Showing Internal Components .....45 Part Number Example .....46 Models .....47 Types .....55
<b>Accessories</b>	Insulators for Crimp Contacts .....84 Crimp Contacts .....85 Bend Relief .....91 Washers and Nuts .....93
<b>Tooling</b>	Wrenches and Assembly Tools .....95 Crimping Tools for Crimp Contacts .....98  PCB Drilling Patterns .....105 Cable Fixing .....111 Technical Tables and Conversion .....113 Terms and Conditions .....115 Forms .....118

## LEMO's Product Line

Connectors, accessories and tools found in this catalog.

- Connectors**
- Single contact from 2 to 150 Amps
  - Coaxial 50 and 75 Ω
  - Coaxial 50 Ω (NIM-CAMAC)
  - Coaxial 50 Ω for frequency → 12 GHz
  - Multicoaxial 50 and 75 Ω
  - Multicontact from 2 to 106 contacts
  - High Voltage 3, 5, 8, 10, 15, 30 and 50 kV cc
  - Multi High Voltage 3, 5, and 10 kV cc
  - Triaxial 50 and 75 Ω
  - Quadrax
  - Mixed: High Voltage (HV) + Low Voltage (LV)
  - Mixed: Coax + LV
  - Mixed: Triax + LV
  - Thermocouple
  - Multithermocouple
  - Fiber optic singlemode
  - Fiber optic multimode
  - Mixed: fiber optic + LV
  - Mixed: fiber optic + coax + LV
  - Fluidic
  - Multifluidic
  - Mixed: fluidic + LV
  - Subminiature
  - Miniature
  - Plastic
  - Printed circuit board
  - Remote handling
  - Watertight
  - Sealed (pressure and/or vacuum)
  - With plastic outer shell
  - With aluminium outer shell
  - With stainless steel outer shell
  - With special radiation resistant insulator material
  - With screw thread coupling for very high pressure
  - With microswitch

- Patch Panels**
- For audio-mono applications: triax
  - For audio-mono applications: 3 contacts
  - For audio-stereo applications: quadrax
  - For audio-stereo applications: 6 contacts
  - For video applications: coax 75 Ω

- Patch Panels**
- For video HDTV applications: 3 coax 75 Ω + 2LV
  - For fiber optic applications





- Adaptors**
- For BNC, C, UHF, N, CINCH, GEN-RADIO connectors
  - For TNC, SMA connectors

- Accessories**
- Insulator for crimp contacts
  - Crimp contacts
  - Coaxial contacts
  - Triaxial contacts
  - Fiber optic contacts
  - Fiber optic ferrules
  - Caps and bend relief
  - Heatshrink boot
  - Insulating washers
  - Double plastic panel washers
  - Locking washers
  - Tapered washers
  - Hexagonal nuts
  - Conical nuts
  - Round nuts
  - Notched nuts
  - Grounding washers
  - Lead-through with cable collet

- Tooling**
- Wrenches
  - Wrenches for assembling plug
  - Assembly tool
  - Pliers
  - Tap
  - Crimping tools
  - Positioners
  - Crimping dies
  - Banding Tool
  - Extractors
  - Insertion testing tool for crimp contacts
  - Fiber optic termination workstation
  - Fiber optic polishing tools

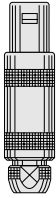
- On request**
- Filtered connectors
  - Connectors with special alloy housing
  - Mixed special connectors
  - Assembly onto cable

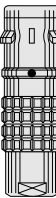
## Characteristics of Primary Series

							
Series	STANDARD	WATERTIGHT	KEYED	KEYED WATERTIGHT	PLASTIC	SCREW	
	01 (Minax)	0E to 6E	00 (multicontact)	0K to 5K	REDEL® 1P	03	
	00 (NIM-CAMAC)	3T	0B to 5B	2N to 5N	REDEL® 2P	0V to 5V	
	00 (single contact)	4M	2G/5G		REDEL® 3P	0W to 5W	
	05 / R0	REDEL® F				2U to 5U	
	0S to 6S						
	0A / 4A						
	1D / 2C						
	1Y-3Y-6Y						
Latching	Push-Pull					Screw	
Key	Stepped insert (Half-Moon)		Key (G) or other key-way code	Key (G) or other key-way code	Key (G) or other key-way code	Key (G) or stepped insert (Half-Moon)	
Shell	Metal or plastic	Metal	Metal or plastic	Metal	Metal	Plastic	Metal
Insert	Hermaphroditic or cylindrical		Cylindrical			Hermaphroditic or cylindrical	
Contact	Solder or printed circuit		Solder, crimp or printed circuit			Solder (crimp or PC)	

# LEMO's Line of Series by Types

**Note:**

- = included in this catalog
- = available but not included in this catalog.

	Series	Series by Types																			
		Single contact	Coaxial 50 Ω	Coaxial 75 Ω	Multicontact	High Voltage	Triaxial 50 Ω	Triaxial 75 Ω	Quadrax	Multi HV	Multi Coaxial	Mixed HV+LV	Mixed Coax+LV	Mixed Triax+LV	Fiber Optic	Multi FO	Mixed FO+LV	Fluidic	Multi fluidic	Mixed fluidic+LV	Thermocouple
Hermaphroditic Keying	01		●																		
	00	●	●					●										●			
	05					●															
	R0		●																		
	0A		●	●																	
	0S	●	●		●	●	●														●
	1S	●	●	●	●	●	●														●
	2S	●	●	●	●	●	●	●													●
	3S	●	●	●	●	●	●	●		●				●							
	4S	●	●	●	●	●	●	●		●	●		●	●							
	5S	●	●	●	●	●	●	●		●	●		●	●							
	6S				●						●		●	●							
	1D								●												
	2C		●		●																
4A							●														
1Y-3Y-6Y					●																
Hermaphroditic Keying — Watertight	0E	■	■		■	■	■													●	
	1E	■	■		■	■	■													●	
	2E	■	■	■	■	■	■					■								●	
	3E	■	■	■	■	■	■		■			■	■								
	4E	■	■	■	■	■	■					■	■	■							
	5E	■			■					■	■	■	■	■							
	6E				■						■		■								
3T			●					●													
4M						●	●														
Mechanical Keying	00				●										●					●	
	0B				●										●			●		●	
	1B				●							●								●	
	2B				●					●	●	●	●	●			●		●	●	
	3B				●						●	●	●	●		●	●		●	●	
	4B				●					●	●	●	●	●		●	●		●	●	
	5B				●					●	●	●	●	●		●	●		●	●	
2G				●																	
5G									●												
Mechanical Keying — Watertight	0K				■									●			■			●	
	1K				■															●	
	2K				■							■	■	■			●		■	●	
	3K			■	■							■	■	■		●	●		■	■	
	4K				■					■	■	■	■	■		●	●		■	■	
	5K				■					■	■	■	■	■		●	●		■	■	
0F to 5F				●																	
3N to 5N				●																	
Plastic	1P to 3P				●							●	●				●				
Screw	03		●		●																
	0V	●	●		●			●												●	
	1V	●	●	●	●			●												●	
	2V	●	●	●	●			●												●	
	3V	●	●	●	●			●				●								●	
	4V	●	●	●	●			●				●	●							●	
	5V	●	●	●	●			●		●	●	●	●							●	
	0W to 5W				●						●	●	●	●			●			●	●
	2U to 5U				●										●	●	●				

## ● QUICK-LOK™ Push-Pull Self-Latching System



LEMO's Original QUICK-LOK push-pull, self-latching system is renowned worldwide for its easy and quick mating and unmating features. It provides absolute security against vibration, shock or pull on the cable, facilitates operation in a very limited space, and offers unique advantages for all applications:

**Speed** – Engage connectors simply and quickly by pushing plugs axially into mating receptacles. Pull on outer shell to remove plug easily.

**Space Savings** – Just one finger clearance on two sides is needed to engage and disengage connectors, so there's no need to twist or turn a locking ring.

**Reliability** – Connections are reliable and assured when locking mechanism is engaged.

**Ruggedness** – Sturdy design, with sealed models to various IP levels.

### How QUICK-LOK™ Works

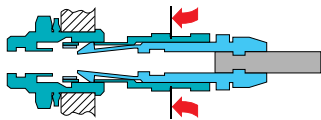
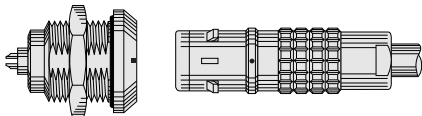

#### Engaging

QUICK-LOK allows the connector to be mated by simply pushing the plug straight into the receptacle.

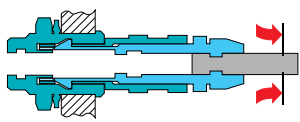

#### Latched

Once firmly latched, connection cannot be broken by pulling on the cable or any other component part other than the outer release sleeve.

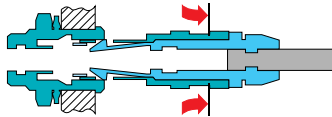

#### Disengaging

When required, the connector is disengaged by a single straight pull on the outer release sleeve. This first disengages the latches and then withdraws the plug from the receptacle.

#### Key:

Fv = average latching force.

Fd = average unmating force with axial pull on the outer release

Fa = average pull force with axial pull on the collet nut.

### Latching Characteristics for K and E Series Connectors

Force (N)	Series					
	0K	1K	2K	3K	4K	5K
Fv	14	16	20	32	65	85
Fd	9	10	13	25	40	60
Fa	250	300	400	550	700	800

Force (N)	Series						
	0E	1E	2E	3E	4E	5E	6E
Fv	14	16	20	32	65	85	100
Fd	9	10	13	25	40	60	75
Fa	250	300	400	550	700	800	900

**Notes:** the forces were measured on outer shell not fitted with contacts. The mechanical endurance represents the number of cycles after which the latching system is still effective (1 cycle = 1 latching/unlatching – 300 cycles per hour).

Mechanical endurance: 5000 cycles.

The values were measured according to the standard MIL-STD-1344A method 2013.1.

1N = 0.102kg.

# ● General Characteristics

## Materials and Surface Treatment

### Outer Shell

#### Brass

In most cases, LEMO connectors have a brass outer shell which is suitable for most general purpose applications, including civilian and military. The brass outer shells have a chrome nickel-plated surface which ensures very good protection against industrial atmosphere, salt air and most corrosive agents.

Alternative protective coatings are available to satisfy other specific environmental conditions:

- Electrolytic nickel;
- Nickel-gold; and
- Nickel-black chrome. After the black chrome treatment, the part is coated with a protective organic film.

### Other metallic components

In general, most metallic components are manufactured in brass. However, bronze or beryllium copper are used where good elasticity is required (for example: grounding crown). Depending upon the application, these parts have electrolytic nickel or nickel-gold plating.

These parts can also be manufactured in stainless steel.

### Sealing gasket

In general, sealing gaskets are made of silicone rubber MQ/MVQ. However, for vacuum-tight receptacles and couplers, gaskets are made of fluorosilicone rubber (FPM).

### Sealing resin

An epoxy resin is used to seal both watertight and vacuum-tight receptacle and coupler models.

Component	Material (Standard)	Surface treatment (µm)										Notes
		chrome			nickel		gold			black chr.		
		Cu	Ni	Cr	Cu	Ni	Cu	Ni	Au	Ni	Cr	
Outer shell, collet nut, conical nut or notched nut and oversized collet	Brass (UNS C 38500)	0.5	3	0.3	0.5	3	0.5	3	0.5	1	2	
	Stainless steel (AISI 303, 304 or 316L)	without treatment										
	Avional (AA 2007)	-	-	-	-	5	-	-	-	-	-	1)
	Aluminium alloy (AA 6012)	anodized										
	POM (Delrin® or Ertacetal®), Polyoxymethylene, black	-										2)
	PEEK, Polyether etherketone, beige	-										3)
	PSU (Udel®), Polysulfone, gray or white	-										4)
	PPSU (Radel®), Polyphenylsulfone, cream	-										4)
	PA.6 (Grilon®), Polyamid	-										5)
Grounding crown	PPS (Ryton®), Polyphenylene sulfide, brown	-										6)
	Bronze (UNS C 54400) or special brass	-	-	-	0.5	3	0.5	3	1.0	-	-	7)
	Beryllium Copper (UNS C 17300)	-	-	-	0.5	3	0.5	3	1.0	-	-	8)
Latch sleeve	Stainless steel (AISI 416 or 316L)	without treatment										9)
	Special brass	0.5	3	0.3	0.5	3	0.5	3	0.5	-	-	
Locking washer	Stainless steel (AISI 416 or 316L)	without treatment										9)
	Bronze (UNS C 52100)	-	-	-	0.5	3	0.5	3	0.5	-	-	
Hexagonal or round nut	Brass (UNS C 38500)	-	-	-	0.5	3	0.5	3	0.5	-	-	
	Stainless steel (AISI 303, 304 or 316L)	without treatment										10)
	Aluminium alloy (AA 6012)	anodized natural										10)
Other metallic components	Brass (UNS C 38500)	-	-	-	0.5	3	0.5	3	0.5	-	-	
	Stainless steel (AISI 303, 304 or 316L)	without treatment										
O-ring and gaskets	Silicone MQ/MVQ or FPM/FKM (Viton®)	-										11)
Sealing resin	Epoxy (Araldite® or Stycast®)	-										

#### Notes:

standards for surface treatment are as follows:

Chrome-plated: FS QQ-C-320B;

Nickel-plated: FS QQ-N-290A, or MIL-C-26074C;

Gold-plated: ISO 4523; and

Black chrome: MIL-C-14538C with a minimum of 10 µm of lacquer protection.

1) anthracite color (other colors upon request)

2) for FFP, PCP and ERN models of the 0S to 3S series

3) for FFP, PCP and ERN models of the 0S to 3S series and FGG and ENG models of the 1B, 3B and 4B series

4) for the FGY and ENY models of the 2B and 3B series

5) for bridge plugs of the B series

6) for S and B series elbow receptacles for printed circuits

7) gold-plating for single contact types

8) used in 00 series free and fixed receptacles and couplers

9) AISI 416 steel is used with shells made of AISI 303 or 304

10) delivered with free and fixed receptacles with aluminium alloy or stainless steel shell

## Electrical Characteristics

### Shell electrical continuity: (measured according to IEC 60512-2 test 2f)

Test current: 1A  
 A = Ammeter  
 mV = Millivoltmeter  
 G = Generator

### Standard and Keyed watertight series

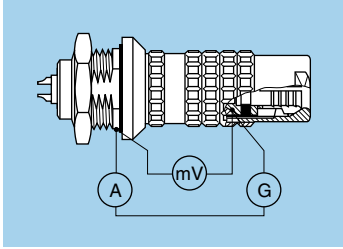

Series	R <sub>1</sub> (mΩ)	R <sub>2</sub> (mΩ)
0E-0K	2.8	1.6
1E-1K	2.2	1.5
2E-2K	1.8	1.2
3E-3K	1.6	1.2
4E-4K	1.4	1.0
5E-5K	1.4	1.0
6E	1.0	0.5

**R<sub>1</sub>** Values with grounding crown and latch sleeve or inner-sleeve nickel-plated.

**R<sub>2</sub>** Values with gold-plated grounding crown and nickel-plated latch sleeve or inner sleeve.

## Electromagnetic compatibility (EMC) and shielding efficiency

The electromagnetic compatibility of a device can only be ensured by meeting a number of basic rules with the design of the device and by carefully selecting components, cables and connectors.

Electrical and electronic devices are to be designed to ensure the following:

- Reduce the emission of generated electromagnetic interference to a level where radios and telecommunication and other devices can properly function;
- Electromagnetic immunity against electromagnetic interference so that they can properly function.

When selecting a connector, screen or shielding efficiency and low resistance to electric continuity between the cable and the connector should be considered.

The design of LEMO connectors with metal shell and grounding crown guarantee optimum shielding efficiency in all applications where electromagnetic compatibility (EMC) is critical.

The performance of a connector is measured through shielding efficiency, a value that represents the ratio between the electromagnetic field on the outside and the inside of the shell. Our measurements are carried out according to the IEC 60169-1-3 standard.

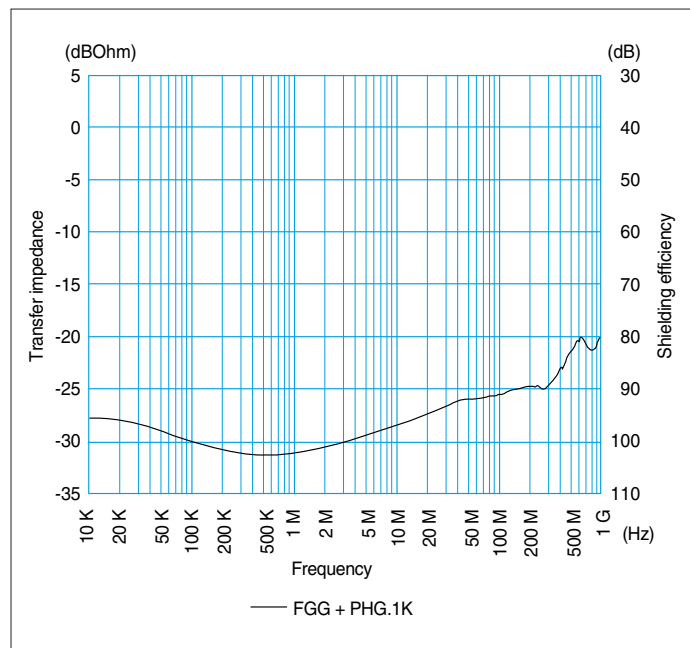

The performance of K and E series connectors is comparable to the results of measurements carried out on a pair of FGG + PHG.1K connectors.



## Insulator

Plastic material used by LEMO for manufacturing insulators is selected according to the electric and thermal properties required for the various connector types. Characteristics examined for the two connector types are:

- Dielectric strength;
- Comparative tracking index;
- Surface and volume resistivity;
- Continuous service temperature;
- Water absorption;
- Radiation resistance;
- Flammability rating;
- Resistance to hydrocarbon.

### Mechanical and Electrical Properties

LEMO uses PEEK (Polyether Etherketone) for the insulator material. The performance of this thermo-plastic material is enhanced by the addition of glass fibers in the resin to achieve very high mechanical strength, to increase dielectric strength and to reduce water absorption rate. The above features of PEEK, plus its excellent chemical and radiation resistance, make it ideal for most applications. Sealing grommets are molded from Viton®. Such polymer has inherently excellent electrical insulating properties which does not change when exposed to adverse environments.

Insulating resistance >10<sup>12</sup>Ω (per MIL-STD-1344A method 3003.1).

### Radiation resistance

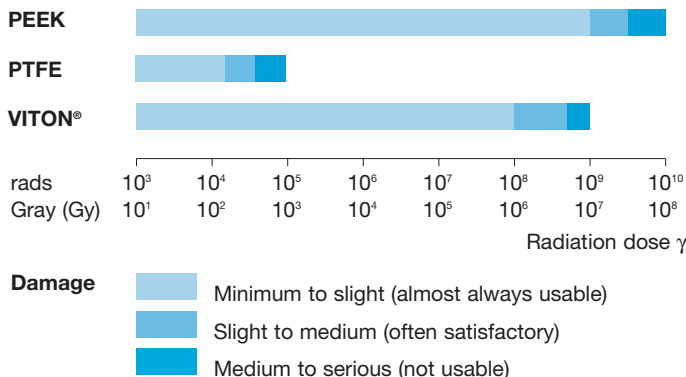

**Note:** Technical data in this chapter provide general information on plastics used by LEMO as electrical insulators. LEMO reserves the right to propose new materials with better technical characteristics, and to withdraw, without notice, any material mentioned in the present catalog or any other publications edited by LEMO SA. and/or its subsidiaries. LEMO SA and its subsidiaries use only plastic granules, powder or bars supplied by specialized companies, and thus cannot in any case take responsibility with regard to this material.

## Technical characteristics

Type	Standard	Units	POM	PEEK	PSU	PPSU	PPS	PA.6	Silicone	FPM	Epoxy
Density	ASTM D 792	-	1.4	1.3-1.4	1.24	1.3	1.67	1.14	~1.2	~1.9	1.58
Tensile strength (at 73.4° F)	ASTM D 638/ ISO R527	MPa	70-80	92-142	70	70	121	55	> 9	> 12	16
Flexural strength (at 73.4° F)	ASTM D 790/ ISO R178	MPa	-	170	106	91	179	75	-	-	24
Dielectric strength	ASTM D 149/IEC 60243	kV/mm	60	19-25	17-20	15	17	35	18-30	-	15
Volume resis. at 50% HR and 73.4° F	ASTM D 257/IEC 60093	Ω • cm	10 <sup>15</sup>	10 <sup>16</sup>	5x10 <sup>16</sup>	-	10 <sup>16</sup>	10 <sup>15</sup>	10 <sup>14</sup>	-	10 <sup>14</sup>
Surface resistivity	ASTM D 257	Ω	10 <sup>13</sup>	10 <sup>15</sup>	-	-	-	-	-	-	-
Thermal conductivity	ASTM C 177	W/K • m	0.31	0.25	0.26	-	0.3	-	-	-	0.8
Comparative tracking index	IEC 60112	V	CTI 600	CTI 150	CTI 150	-	CTI 200	CTI 600	-	-	CTI>600
Maxi. continuous service temperature	UL 746	°F	194	482	284	356	428	176	392	392	176
Min. continuous service temperature	UL 746	°F	-58	-67	-76	-58	-106	-40	-58	-4	-4
Max. short-time service temperature	-	°F	284	572	320	392	482	302	> 482	572	248
Water absorption in 24h at 73.4° F	ASTM D 570/ISO R62A	%	0.85	0.12	0.3	0.37	< 0.05	> 3	-	-	0.25
Radiation resistance	-	Gy <sup>1)</sup>	8x10 <sup>3</sup>	10 <sup>7</sup>	10 <sup>5</sup>	-	> 10 <sup>7</sup>	5x10 <sup>3</sup>	10 <sup>5</sup>	8x10 <sup>4</sup>	2x10 <sup>6</sup>
Flammability rating	ASTM D 635/UL 94	-	HB	V-0/3.2	V-0/4.4	V-0/1.6	V-0/5V	V-2	-	-	V-0/4
Resistance to steam sterilization	-	-	bad	excel.	good	excel.	excel.	bad	good	good	bad

Notes: <sup>1)</sup> 1 Gy (Gray) = 100 rad

ASTM = American Society for Testing Material  
 ISO = International Standards Organization

UL = Underwriters Laboratories  
 IEC = International Electrotechnical Commission

Note: Values of insulation resistance between contacts are given on page 9.

## Electrical Contact

### Technical Description

The secure reliable electromechanical connection achieved with LEMO female cylindrical contacts is mainly due to two important design features:

1. *Prod proof entry* on the mating side which ensures perfect concentric mating even with carelessly handled connectors; and
2. *The pressure spring*, with good elasticity, maintains a constant even force on the male contact when mated. The leading edge of the pressure spring preserves the surface treatment (gold-plated) and prevents undue wear.

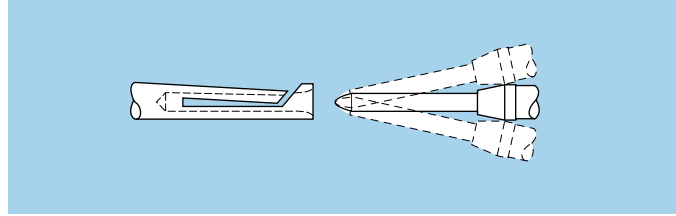

### Contact Material and Treatment

LEMO female contacts are made of bronze beryllium (QQ-C-530) or bronze (UNS C 54400). These materials are chosen because of their high modulus of elasticity, their excellent electrical conductivity and a high mechanical strength.

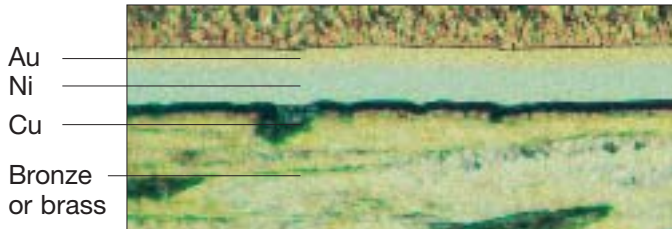

**Notes:** The standard surface treatment are as follows:  
 Nickel: FS QQ-N-290A or MIL-C-26074C; and  
 Gold: ISO 4523.

- 1) Minimum value 2) For elbow printed circuit contacts  
 3) Treatment completed by 6  $\mu\text{m}$  Sn-Pb tin-plating

LEMO male solder and printed circuit contacts are made of brass (UNS C 38500). Male crimp contacts are made of brass (UNS C 34500) or annealed brass (UNS C 38500) with optimum hardness (HV) for crimping onto the wire.

Type	Material (standard)	Surf. treatment ( $\mu\text{m}$ )		
		Cu	Ni	Au <sup>1)</sup>
Male crimp	Brass (UNS C 34500)	0.5	3	1.0
Male printed circuit	Brass (UNS C 38500)			
Female crimp	Bronze (UNS C 54400)	0.5	3	1.5
Female printed circuit	Cu-Be (FS QQ-C-530)			
Clips	Cu-Be (FS QQ-C-530)	-	-	-
	Stainless steel	-	-	-
Wire <sup>2)</sup>	Brass	-	3 <sup>3)</sup>	-

### Thickness comparison between the outside and the inside of female contacts

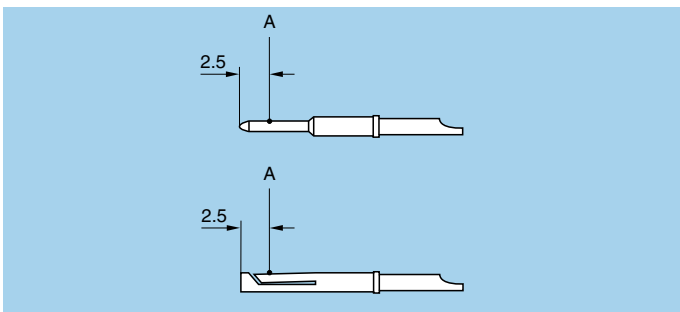

**Note:** A = inspection point

Contact $\phi$ A (mm)	Gold thickness		
	male ( $\mu\text{m}$ )	female	
		outside ( $\mu\text{m}$ )	inside (%)
0.5	1.0	1.5	65
0.7	1.0	1.5	70
0.9	1.0	1.5	75
1.3	1.0	1.5	75
1.6	1.0	1.5	75
2.0	1.0	1.5	75
3.0	1.0	1.5	75
4.0	1.0	1.5	75
5.0	1.0	1.5	75
6.0	1.0	1.5	75
8.0	1.0	1.5	75
12.0 <sup>1)</sup>	-	-	-

**Notes:** 1) Contacts are silver plated.

## Electrical Contact

### Contact resistance with relation to the number of mating cycles

Maximum values measured after the mating cycles and the salt spray test according to IEC 60512-6 test 11f.

A $\phi$ (mm)	Contact resistance (m $\Omega$ )			A $\phi$ (mm)	Contact resistance (m $\Omega$ )		
	1000 cycles	3000 cycles	5000 cycles		1000 cycles	3000 cycles	5000 cycles
0.5	7.5	8.3	8.7	3.0	2.0	2.2	3.1
0.7	5.6	5.7	6.1	4.0	1.6	2.0	2.8
0.9	4.1	4.2	4.8	5.0	1.4	–	–
1.3	2.8	2.9	3.6	6.0	1.2	–	–
1.6	2.6	2.7	3.5	8.0	0.8	–	–
2.0	2.9	3.1	3.3	12.0	0.7	–	–

(measured according to IEC 60512-2 test 2a)

### Insulation resistance between the contacts and contact/shell

(measured according to IEC 60512-2 test 3a)

Insulating material	Multicontact	Single contact
	PEEK	PTFE
new	> 10 <sup>12</sup> $\Omega$	> 10 <sup>12</sup> $\Omega$
after humidity test <sup>1)</sup>	> 10 <sup>10</sup> $\Omega$	> 10 <sup>10</sup> $\Omega$

**Note:**

<sup>1)</sup> 21 days at 95% RH according to IEC 60068-2-3.

## Solder Contacts

The conductor bucket of these contacts is machined at an angle to form a cup into which the solder can flow.

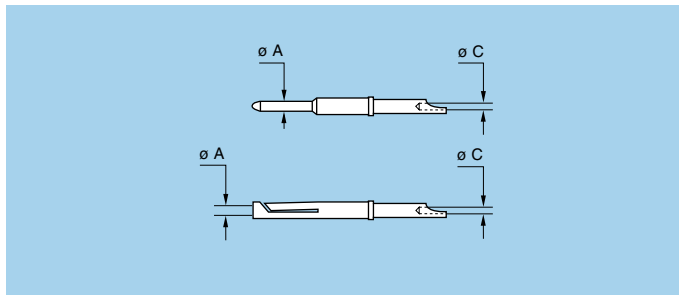

**Note:**

- <sup>1)</sup> For E series
- <sup>2)</sup> For 00 multicontact series
- <sup>3)</sup> For a given AWG, the diameter of some stranded conductor designs is larger than the solder cup diameter. Make sure that the maximum conductor diameter is smaller than  $\phi$  C.

Contact		Conductor			
$\phi$ A (mm)	$\phi$ C (mm)	Solid		Stranded	
		AWG max.	Section max (mm <sup>2</sup> )	AWG max.	Section max (mm <sup>2</sup> )
0.5 <sup>2)</sup>	0.40 <sup>2)</sup>	28	0.09	30	0.05
0.5	0.45	28	0.09	28	0.09
0.7 <sup>1)</sup>	0.60 <sup>1)</sup>	24	0.25	26	0.14
0.7	0.80	22	0.34	22 <sup>3)</sup>	0.34
0.9	0.80	22	0.34	22 <sup>3)</sup>	0.34
1.3	1.00	20	0.50	20 <sup>3)</sup>	0.50
1.6	1.40	16	1.00	18	1.00
2.0	1.80	14	1.50	16	1.50
3.0	2.70	10	4.00	12	4.00
4.0	3.70	10	6.00	10	6.00
5.0	5.20	–	–	8	10.00
6.0	5.20	–	–	8	10.00
8.0	7.00	–	–	4	16.00
12.0	6.20	–	–	6	16.00

## Electrical Contact

### Crimp Contacts

The square form crimp method is used (MIL-C-22520F, class I, type 2) photo 1 for single contact contacts.

For multicontact contacts the standard four-finger crimp method is used, (MIL-C-22520F, class I, type 1), photo 2. The crimp method requires a controlled compression to obtain a symmetrical deformation of the conductor strand and of the contact material. The radial hole in the side of the contact makes it possible to check whether the conductor is correctly positioned within the contact. A good crimping is characterized by only slightly reduced conductor section and practically no gap.

For optimum crimping of bronze or brass contacts they are annealed to relieve internal stress and reduce material hardening during the crimping process.

Only the crimping zone is annealed with the help of an induction heating machine designed by the LEMO Research and Development Department (see photo 3).

### Advantages of crimping

- practical, quick contact fixing outside the insulator
- possible use at high temperature
- no risk of heating the insulator during the conductor-contact fixing
- high tensile strength

Crimp contacts are available in standard version (figure 1) for mounting maximum size conductors. For some dimensions, these crimp contacts can be produced with reduced crimp barrels (figure 2) for mounting reduced size conductors.

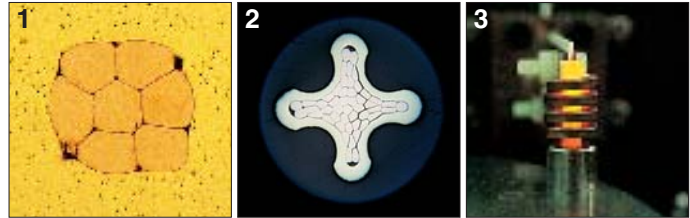

Contacts are provided in two forms: with a standard crimp barrel for large conductors (see fig. 1), or with a reduced crimp barrel for smaller conductors (see fig. 2).

A detailed range of conductor dimensions that can be crimped into our contacts is given on the table below.

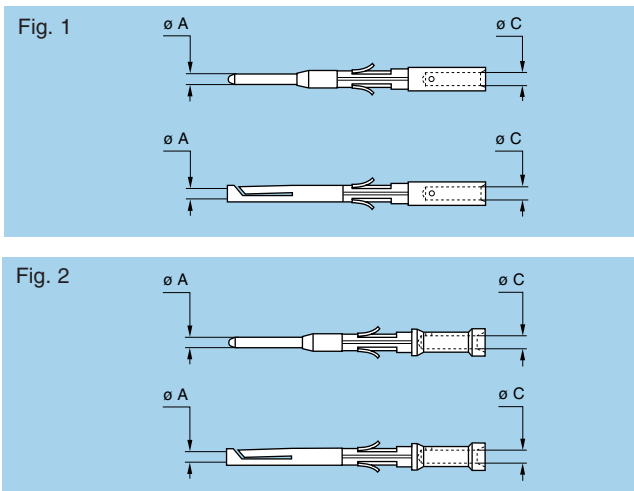

**Note:** 1) For a given AWG, the diameter of some stranded conductor designs is larger than the solder cup diameter. Make sure that the maximum conductor diameter is smaller than  $\varnothing C$ .

Contact			Conductor stranded				F <sub>r</sub> (N)
$\varnothing A$ (mm)	$\varnothing C$ (mm)	Form per fig.	AWG stranded		Section (mm <sup>2</sup> )		
			min.	max.	min.	max.	
0.5	0.45	1	32	28	0.035	0.09	12
0.7	0.80	1	26	22 <sup>1)</sup>	0.140	0.34	22
	0.45	2	32	28	0.035	0.09	
0.9	1.10	1	24	20	0.250	0.50	30
	0.80	2	26	22 <sup>1)</sup>	0.140	0.34	
	0.45	2	32	28	0.035	0.09	
1.3	1.40	1	20	18	0.500	1.00	40
	1.10	2	24	20	0.250	0.50	
	0.80	2	26	22 <sup>1)</sup>	0.140	0.34	
1.6	1.90	1	18	14 <sup>1)</sup>	1.000	1.50	50
	1.40	2	22	18	0.340	1.00	
2.0	2.40	1	16	12 <sup>1)</sup>	1.500	2.50	65
	1.90	2	18	14	1.000	1.50	
3.0	2.90	1	14	10 <sup>1)</sup>	2.500	4.00	75
4.0	4.00	1	12	10	4.000	6.00	90

**Note:** Fr = mean contact retention force in the insulator (according to IEC 60512-8 test 15a).

### Printed Circuit Contacts

Printed circuit contacts are available in straight or elbow versions for certain connector types, mostly for straight and elbow receptacle models. Connection is made on flexible or rigid printed circuits by soldering.

Printed circuit contacts are gold-plated which guarantees optimum soldering, even after long-term storage. However for wave soldering, we recommend removal of the gold-plating from the contact end on the printed circuit side before soldering according to the assembly procedures.

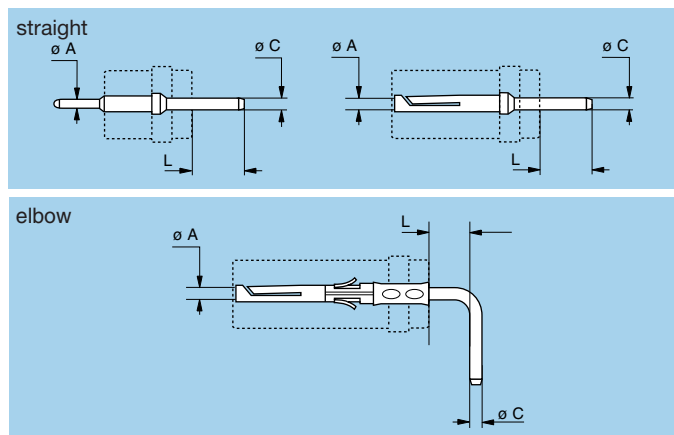

## Electrical Contact

### Test Voltage

Test voltage (Ue):  
(measured according to the IEC 60512-2 test 4a standard).

It corresponds to 75% of the mean breakdown voltage. Test voltage is applied at 500 V/s and the test duration is one minute.

This test has been carried out with a mated plug and receptacle, with power supply only on the plug end.

Operating voltage (Us):  
It is proposed according to the following ratio:  $Us = \frac{Ue}{3}$

**Caution:**  
**For a number of applications, safety requirements for electrical appliances are more severe with regard to operating voltage.**

**In such cases operating voltage is defined according to creepage distance and air clearance between live parts.**

**Please consult us for the choice of a connector by indicating the safety standard to be met by the product.**

Voltage values are given in the table on insulator types for each series corresponding with values measured at sea level and are adapted to all applications up to an altitude of 2000 m.

In case a device is used at a higher altitude, air clearance between live parts has to be multiplied by the following coefficients:  
(Test voltage also has to be divided by this coefficient).

altitude (m)	coefficient
2000	1.00
3000	1.14
4000	1.29
5000	1.48

### Rated Current

(measured according to IEC 60512-3 test 5a).

The specified rated current can be applied simultaneously to all the contacts, corresponding with an average temperature rise of 104° F of the connector.

The current values are indicated in the table of insulator types in each series. For use at higher temperatures, acceptable rated current will be lower. It tends towards zero as the material is used at the maximum operating temperature accepted for the insulator.

In most cases, the current depends on the conductor dimension, or on the printed circuit dimension.

**Caution:**  
**In general, connectors should not be unmated while live.**

For connectors with PEEK insulator, maximum admissible current will follow the curve below depending on the operating temperature T.

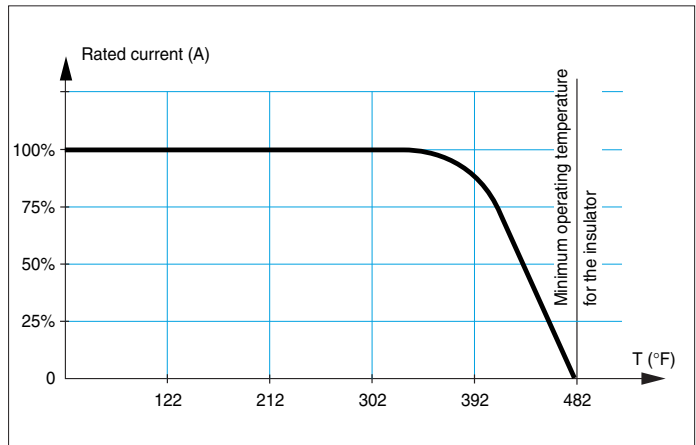



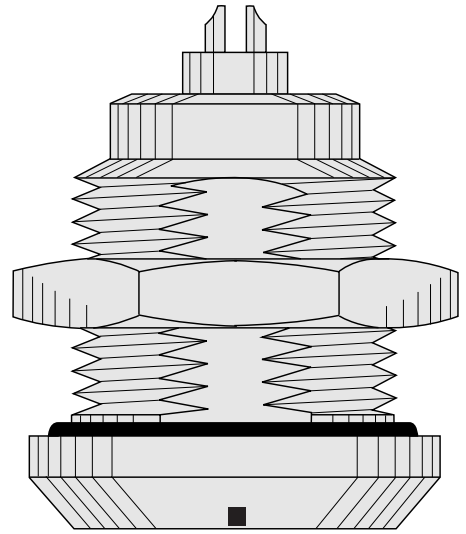

- **K Series Connectors**

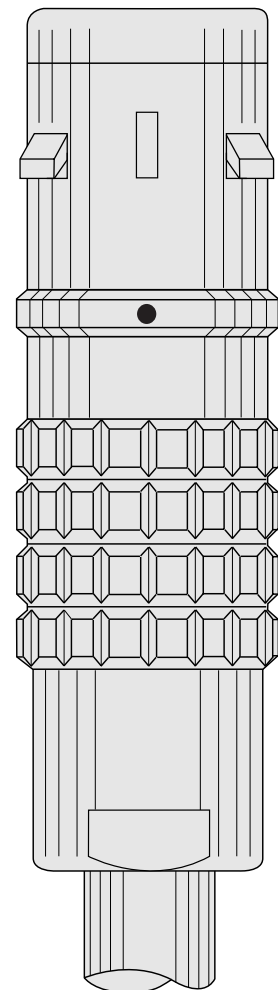





## Model Description

- EBG** Fixed receptacle with square flange, key (G) or keys (A to F, L and R), screw fixing
- EDG** Fixed receptacle with square flange, key (G) or keys (A to F, L and R), protruding shell and grounding tab, screw fixing
- EEG** Fixed receptacle, nut fixing, key (G) or keys (A to F, L and R), (back panel mounting)
- EEG** Fixed receptacle, nut fixing, key (G) or keys (A to F, L and R) with straight printed circuit contacts for printed circuit (back panel mounting)
- EEG** Fixed receptacle, nut fixing, key (G) or keys (A to F and L) with elbow (90°) contacts for printed circuit (back panel mounting)
- EGG** Fixed receptacle, nut fixing, key (G) or keys (A to F, L and R)
- EHG** Fixed receptacle, nut fixing, key (G) or keys (A to F and L), protruding shell
- EMG** Fixed receptacle, nut fixing, with microswitch, key (G) or keys (A to F and L)
- ENG** Fixed receptacle, nut fixing, key (G) or keys (A to F, L and R) and grounding tab
- EVG** Fixed receptacle, nut fixing, key (G) or keys (A to F and L) and dust cap (spring loaded)
- FAG** Fixed plug, nut fixing, non-latching, key (G) or keys (A to F, L and R)
- FGG** Straight plug, key (G) or keys (A to F, L and R), cable collet
- FGG** Straight plug, key (G) or keys (A to F, L and R), cable collet and oversize cable collet
- FGG** Straight plug, key (G) or keys (A to F, L and R), cable collet and nut for fitting a bend relief
- FHG** Elbow (90°) plug, key (G) or keys (A to F, L and R), cable collet
- FNG** Straight plug, key (G) or keys (A to F and L), cable collet and lanyard release
- FTG** T-plug, key (G) with receptacles (90°), key (G)
- FXG** Fixed plug with round flange, key (G) or keys (A to F, L and R), screw fixing
- HEG** Fixed receptacle, nut fixing, key (G) or keys (A to F and L), watertight or vacuum-tight (back panel mounting)
- HGG** Fixed receptacle, nut fixing, key (G) or keys (A to F and L), watertight or vacuum-tight
- PBG** Fixed receptacle, key (G) with square flange, cable collet, screw fixing
- PEG** Fixed receptacle, nut fixing, key (G) or keys (A to F, L and R), cable collet (back panel mounting)
- PHG** Free receptacle, key (G) or keys (A to F, L and R), cable collet and oversize cable collet
- PHG** Free receptacle, key (G) or keys (A to F, L and R), cable collet and nut for fitting a bend relief
- PHG** Free receptacle, key (G) or keys (A to F, L and R), cable collet and nut for fitting a bend relief
- PKG** Fixed receptacle, nut fixing, key (G) or keys (A to F, L and R), cable collet
- S••** Fixed coupler, nut fixing, key (G) or keys (L) at the flange end, and key (G) or keys (C or L) at the other end, watertight or vacuum-tight
- TGL** Free coupler, key (G) on one side and keys (L) on the other

## Part Section Showing Internal Components

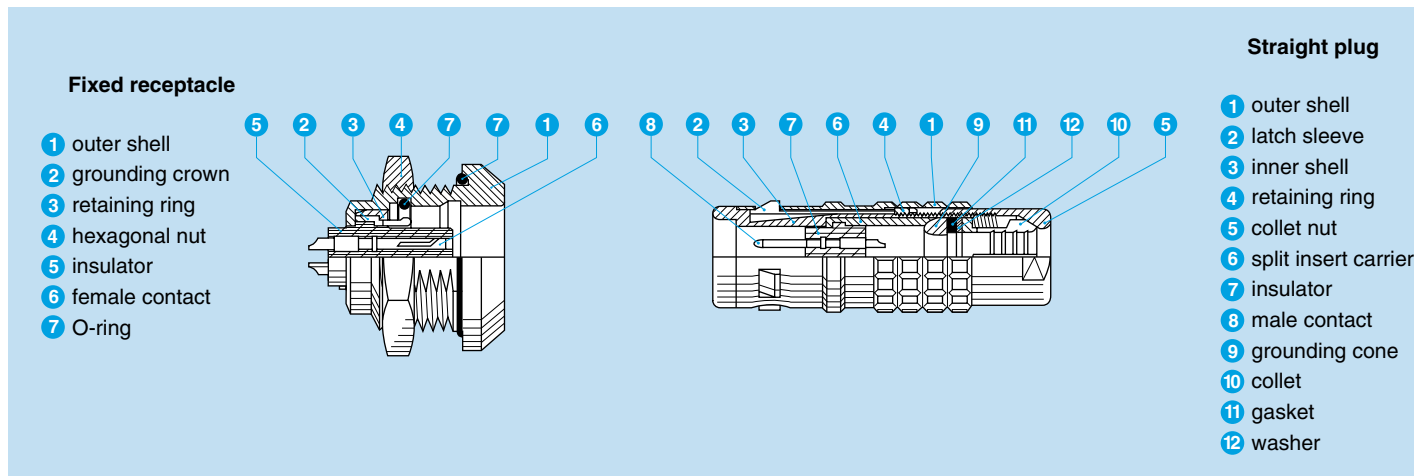

## Technical Characteristics

### Mechanical and Climatic

Characteristics	Value	Standard
Endurance	> 5000 cycles	IEC 60512-5 test 9a
Humidity	up to 95% at 140° F	
Temperature range <sup>1) 2)</sup>	-58° F, +392° F	
Resistance to vibrations	10-2000 Hz, 15 g	IEC 60512-4 test 6d
Shock resistance	100 g, 6 ms	IEC 60512-4 test 6c
Salt spray corrosion test	> 144h	IEC 60512-6 test 11f
Protection index (mated)	IP 68/IP 66	IEC 60529
Climatic category <sup>1)</sup>	50/175/21	IEC 60068-1

### Electrical

Characteristics	Value	Standard
Shielding efficiency	at 10 MHz	> 95 dB
	at 1 GHz	> 80 dB

**Note:**  
 The various tests have been carried out with FGG and EGG connector pairs, with chrome-plated brass shell, PEEK insulator and silicone O-ring.  
 Detailed electrical characteristics, as well as materials and treatment are presented on page 6.  
<sup>1)</sup> For watertight or vacuum-tight models see page 25.  
<sup>2)</sup> Minimum operating temperature is -4°F for receptacles fitted with an FPM (Viton) O-ring.

## Available Models (series and types)

Model	Multicontact					
	0K	1K	2K	3K	4K	5K
EBG				●	●	●
EDG				●		
EEG	●	●	●	●	●	
EEG <sup>4)</sup>	●	●	●	●		
EGG	●	●	●	●	●	●
EHG		●	●			
EMG			●			
ENG				●		
EVG	●					

Model	Multicontact					
	0K	1K	2K	3K	4K	5K
FAG			●	●	●	●
FGG	●	●	●	●	●	●
FGG <sup>1)</sup>		●	●	●	●	
FGG <sup>2)</sup>	●	●	●	●	●	
FHG	●	●	●	●	●	
FNG			●		●	
FTG			●			
FXG				●	●	●
HEG	●	●	●			

Model	Multicontact					
	0K	1K	2K	3K	4K	5K
HGG	●	●	●	●	●	●
PBG				●		
PEG	●	●	●	●		
PHG	●	●	●	●	●	●
PHG <sup>1)</sup>		●	●	●	●	
PHG <sup>2)</sup>	●	●	●	●	●	
PKG	●	●	●	●	●	●
S●●			●		●	●
TGL <sup>3)</sup>				●		

**Note:**

- 1) With oversize cable collet.
  - 2) With nut for fitting a bend relief.
  - 3) The TGL model is not available in all types. Please consult the page corresponding to this model.
  - 4) With elbow (90°) printed circuit contacts.
- = available models by series and types

## Alignment Key and Polarized Keying System

Part numbers for the keyed series are composed of three letters. The LAST LETTER indicates the key position and the contact type (male or female). For example, straight plugs with «G» key or A, B, C, D, E, F, R keys, are fitted with male contacts; whereas with L keys, plugs are fitted with female contacts.

Straight receptacles with «G» key or A, B, C, D, E, F, R keys, are fitted with female contacts; whereas with L keys, receptacles are fitted with male contacts.

Front view of a receptacle 	Model	# of keys	Angles	Series						Contact type			Note
				0K	1K	2K	3K	4K	5K	Plug	Receptacle	Coupler <sup>1)</sup>	
	●●G	1		0°	0°	0°	0°	0°	0°	male	female	female-male	■
	●●A	2	α	30°	30°	30°	30°	30°	30°	male	female	female-male	■
	●●B	2		45°	45°	45°	45°	45°	45°	male	female	female-male	■
	●●C	2		60°	60°	60°	60°	60°	60°	male	female	female-male	■
	●●D	2	γ	95°	95°	95°	95°	95°	95°	male	female	female-male	□
	●●E	2		120°	120°	120°	120°	120°	120°	male	female	female-male	□
	●●F	2	β	145°	145°	145°	145°	145°	145°	male	female	female-male	□
	●●L	2		γ	75°	75°	75°	75°	75°	75°	female	male	male-female

Front view of a receptacle 	Model	# of keys	Angles	Series						Contact type			Note
				0K	1K	2K	3K	4K	5K	Plug	Receptacle	Coupler <sup>1)</sup>	
	●●R	5	α	–	–	–	95°	–	–	male	female	female-male	■
			β	–	–	–	115°	–	–				
			γ	–	–	–	35°	–	–				
			δ	–	–	–	25°	–	–				

**Note:**

- S●● and TGL models are not available with all the keys.
- For S●● models see explanation on page 26.
- Please consult the pages corresponding to these models.
- 1) The first contact type mentioned is always the one at the flange end.

■ First choice alternative □ Special order alternative

## ● Part Number Example

### Straight plug with cable collet

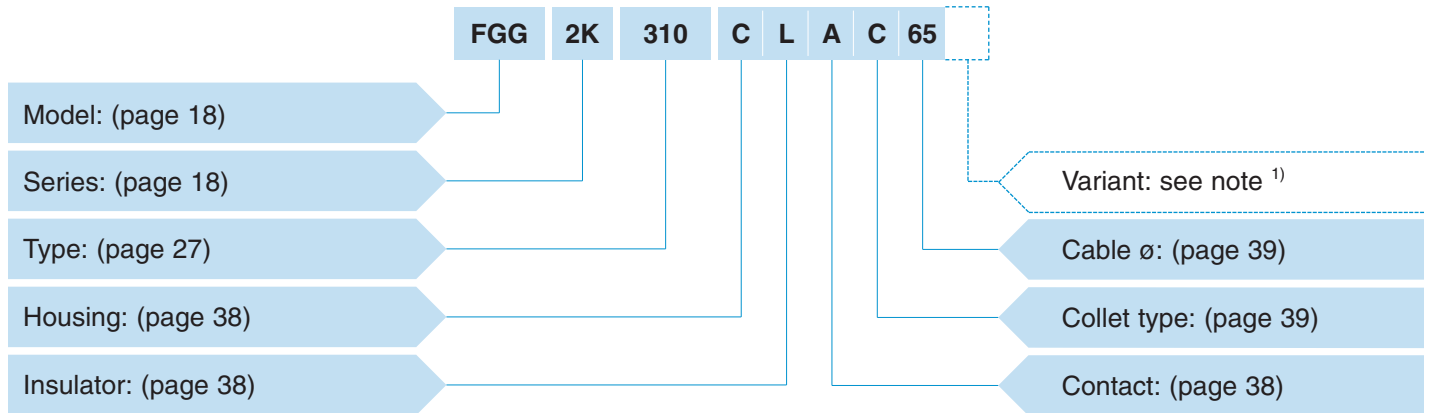

**FGG.2K.310.CLAC65** = straight plug with key (G) and cable collet, 2K series, multicontact type with 10 contacts, outer shell in chrome-plated brass, PEEK insulator, male solder contacts, C type collet for 6.5 mm diameter cable.

### Fixed receptacle

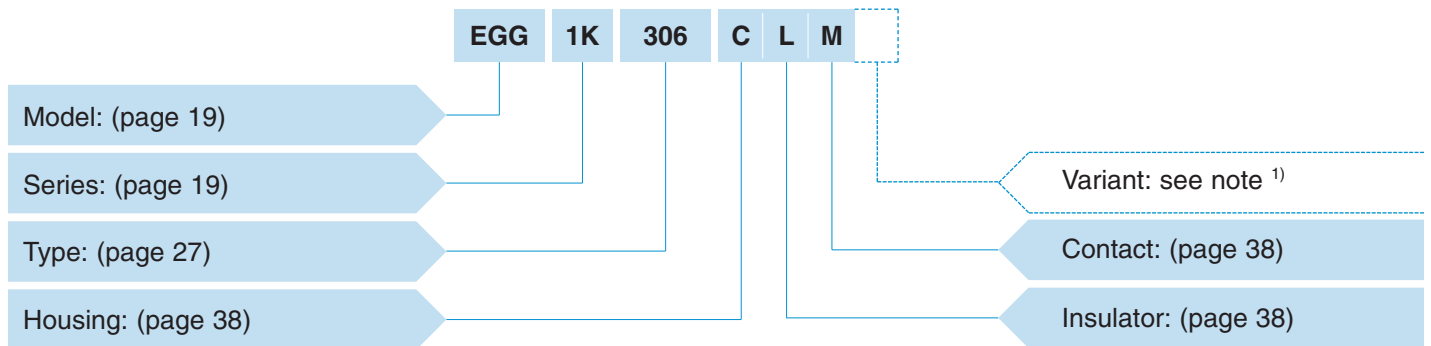

**EGG.1K.306.CLM** = fixed receptacle, nut fixing, with key (G), 1K series, multicontact type with 6 contacts, outer shell in chrome-plated brass, PEEK insulator, female crimp contacts.

### Straight receptacle

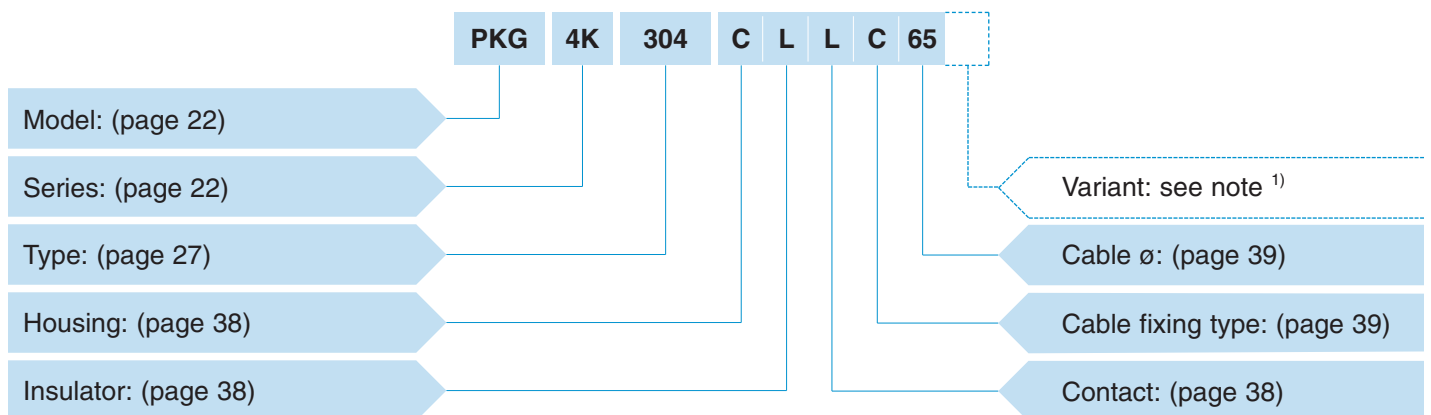

**PKG.4K.304.CLLC65** = straight receptacle, nut fixing, with key (G), 4K series, multicontact type with 4 contacts, outer shell in chrome-plated brass, PEEK insulator, female solder contacts, C type collet for 6.5 mm diameter cable.

**Note:** <sup>1)</sup> The «Variant» position in the reference is used to specify either the presence of a collet nut for fitting the bend relief or the anodized color of the housing in aluminium alloy.  
 For models with collet nut for fitting the bend relief, a «Z» should be indicated and a bend relief can be ordered separately as indicated in the «Accessories» section. An order for a connector with bend relief should thus include two part numbers.  
 For the various housings available in colors, the corresponding letter in the part number for the color is indicated on page 81.  
 For the watertight models of receptacle, the letter «P» is used; for the vacuum-tight models of receptacle the letters «PV» shall be indicated.  
 For the plug and receptacle that should be fitted with an FPM (Viton) O-ring the letter «H» shall be indicated.

## • Models

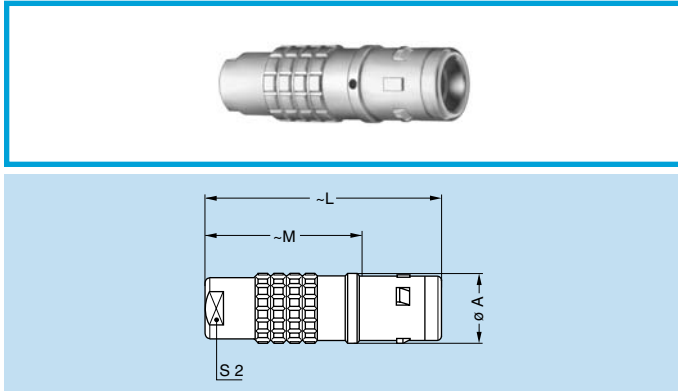

### FGG Straight plug, key (G) or keys (A to F, L and R), cable collet

Reference		Dimensions (mm)				Availability
Model	Series	A	L	M	S2	
FGG	0K	11	34	23.0	8	●
FGG	1K	13	42	28.0	9	●
FGG	2K	16	52	36.0	12	●
FGG	3K	19	61	41.0	15	●
FGG	4K	25	71	50.5	19	○
FGG	5K	38	92	67.0	30	○

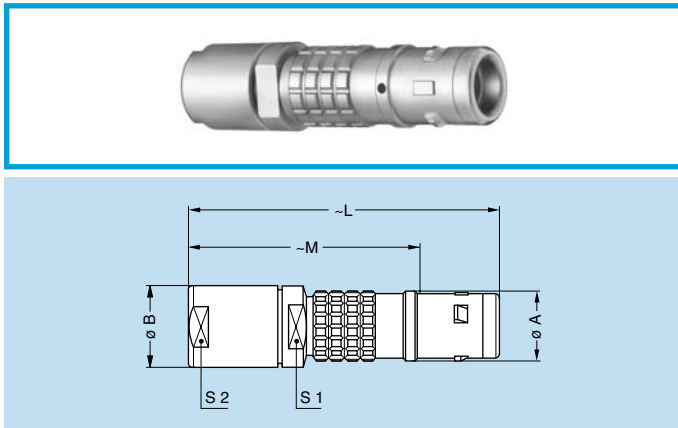

### FGG Straight plug, key (G) or keys (A to F, L and R), and oversize cable collet

Reference		Dimensions (mm)						Availability
Model	Series	A	B	L	M	S1	S2	
FGG	1K	13	14.5	55	41.0	12	12	○
FGG	2K	16	17.0	65	49.0	15	15	○
FGG	3K	19	22.0	80	60.0	19	19	○
FGG	4K	25	36.0	107	86.0	30	32	○

**Note:** The fitting of oversize collets onto this model allows them to be fitted to the cables that can be accommodated by the next housing size up.

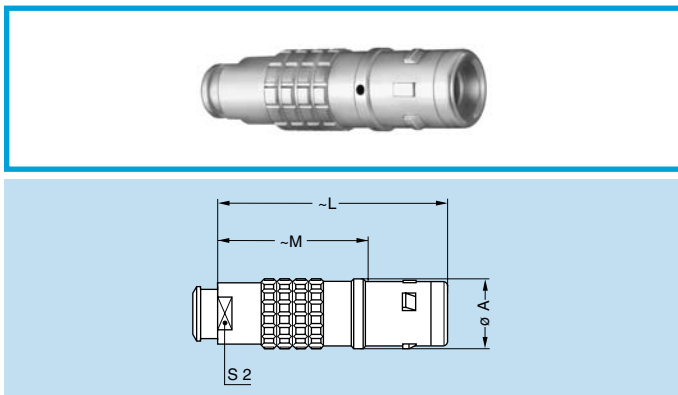

### FGG Straight plug, key (G) or keys (A to F, L and R), cable collet and nut for fitting a bend relief

Reference		Dimensions (mm)				Availability
Model	Series	A	L	M	S2	
FGG	0K	11	34	23.0	7	●
FGG	1K	13	42	28.0	9	●
FGG	2K	16	52	36.0	12	●
FGG	3K	19	60	40.0	15	●
FGG	4K	25	71	50.5	19	○

**Note:** The bend relief must be ordered separately (see page 91).

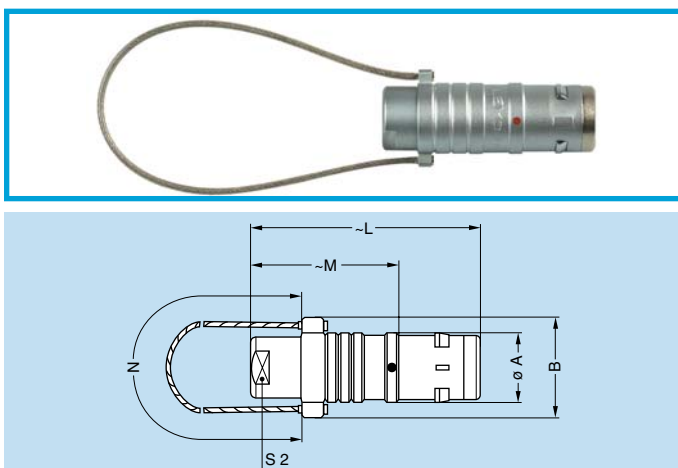

### FNG Straight plug, key (G) or keys (A to F and L), cable collet and lanyard release

Reference		Dimensions (mm)						Availability
Model	Series	A	B	L	M	N	S2	
FNG	2K	16	23.6	52	36.0	160	12	○
FNG	4K	25	35.2	71	50.5	230	19	○

**Note:** Cable material – stainless steel with PVC sheath.

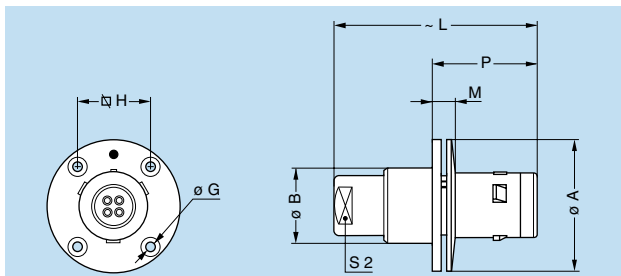
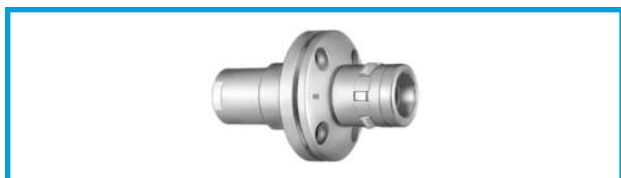

**FXG Fixed plug with round flange, key (G) or keys (A to F, L and R) and screw fixing**

Reference		Dimensions (mm)								Availability
Model	Series	A	B	G	H	L	M	P	S2	
FXG	3K	38	22.5	3.4	20.6	61	10.0	30.0	15	○
FXG	4K	47	28.5	3.4	27.0	71	11.0	32.0	19	○
FXG	5K	65	42.5	4.4	38.0	100	12.5	38.5	30	○

Panel cut-out: **P6**

**Note:** This model does not include an O-ring behind the flange, it allows the device on which it is fitted to reach only IP50 protection index. It does not have a cable collet.

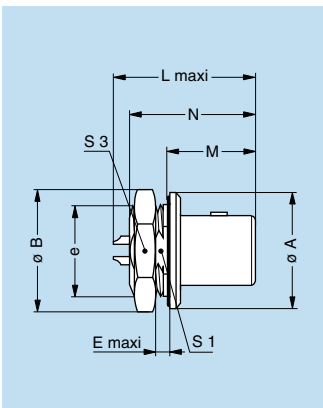

**FAG Fixed plug, nut fixing, non-latching, key (G) or keys (A to F, L and R)**

Reference		Dimensions (mm)									Availability
Model	Series	A	B	e	E	L	M	N <sup>1)</sup>	S1	S3	
FAG	2K	25	27.5	M20x1.0	4.5	28.2	18.0	28.3	18.5	24	○
FAG	3K	31	34.5	M24x1.0	4.0	34.3	22.5	33.8	22.5	30	○
FAG	4K	37	41.5	M30x1.0	4.0	35.3	23.0	36.3	28.5	36	○
FAG	5K	55	54.0	M45x1.5	4.0	43.5	28.5	42.3	42.5	-	○

Panel cut-out: **P1**

**Note:** <sup>1)</sup> Maximum length with crimp contacts.

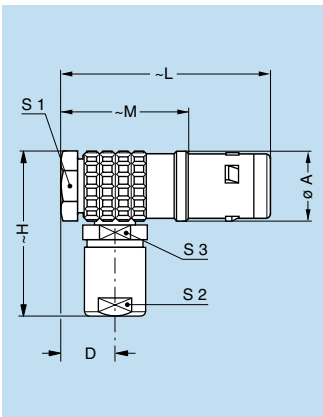

**FHG Elbow (90°) plug, key (G) or keys (A to F, L and R), cable collet**

Reference		Dimensions (mm)								Availability
Model	Series	A	D	H	L	M	S1	S2	S3	
FHG	0K	11.5	7.6	27	36	25.0	10	8	8	○
FHG	1K	14.0	8.8	33	43	29.0	12	9	10	○
FHG	2K	17.5	10.5	40	51	35.0	15	12	13	○
FHG	3K	21.0	11.5	47	60	40.0	18	15	15	○
FHG	4K	27.5	15.5	57	72	51.5	24	19	20	○

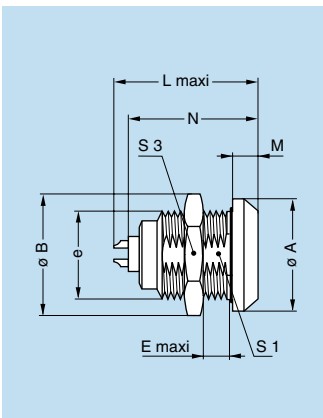

**EGG Fixed receptacle, nut fixing, key (G) or keys (A to F, L and R)**

Reference		Dimensions (mm)									Availability
Model	Series	A	B	e	E	L	M	N <sup>1)</sup>	S1	S3	
EGG	0K	18	19.5	M14x1.0	6	21.7	4.0	20.1	12.5	17	●
EGG	1K	20	21.5	M16x1.0	9	27.0	4.5	25.1	14.5	19	●
EGG	2K	25	27.5	M20x1.0	9	30.7	5.0	28.6	18.5	24	●
EGG	3K	31	34.5	M24x1.0	11	36.2	6.0	33.6	22.5	30	○
EGG	4K	37	40.5	M30x1.0	9	40.2	6.5	38.6	28.5	36	○
EGG	5K	55	54.0	M45x1.5	10	47.5	9.0	43.6	42.5	-	○

Panel cut-out: **P1** **Note:** <sup>1)</sup> Maximum length with crimp contacts. The 5K series is delivered with a round nut.

● Standard, typically 0-6 weeks delivery for quantities of 250 or less.  
○ Non-standard product, contact LEMO USA, typically 6-12 weeks delivery for quantities of 250 or less.  
Non-standard product is defined as any product which contains one or more components which are not standard.

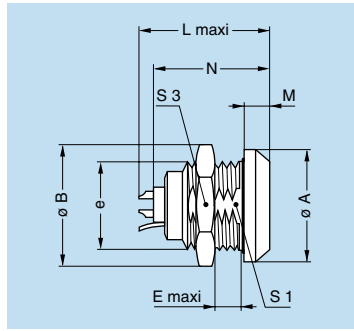

### ENG Fixed receptacle, nut fixing, key (G) or keys (A to F, L and R) and grounding tab

Reference		Dimensions (mm)									Availability
Model	Series	A	B	e	E	L	M	N <sup>1)</sup>	S1	S3	
ENG	3K	31	34.7	M24x1.0	11.3	36.2	6	33.6	22.5	30	○

Panel cut-out: **P1**

**Note:** 1) Maximum length with crimp contacts.

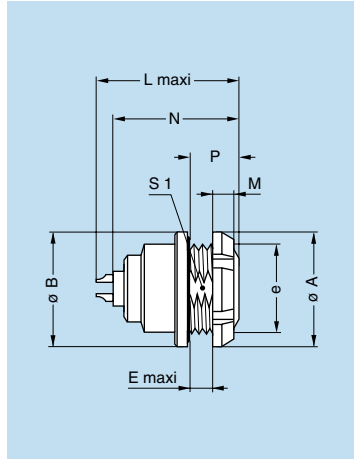

### EEG Fixed receptacle, nut fixing, key (G) or keys (A to F, L and R) (back panel mounting)

Reference		Dimensions (mm)										Availability
Model	Series	A	B	e	E	L	M	N <sup>1)</sup>	P	S1		
EEG	0K	18.0	18	M14x1.0	3.4	21.7	3.5	20.1	7.0	12.5	○	
EEG	1K	20.0	20	M16x1.0	6.2	27.0	3.5	25.1	10.0	14.5	○	
EEG	2K	25.0	25	M20x1.0	5.0	30.7	3.5	28.6	10.0	18.5	○	
EEG	3K	30.0	31	M24x1.0	7.5	36.2	4.5	33.6	12.0	22.5	○	
EEG	4K	41.5	37	M30x1.0	6.0	40.2	7.0	38.6	13.5	28.5	○	

Panel cut-out: **P1**

**Note:** 1) Maximum length with crimp contacts.  
The 3K and 4K series are delivered with a conical nut.

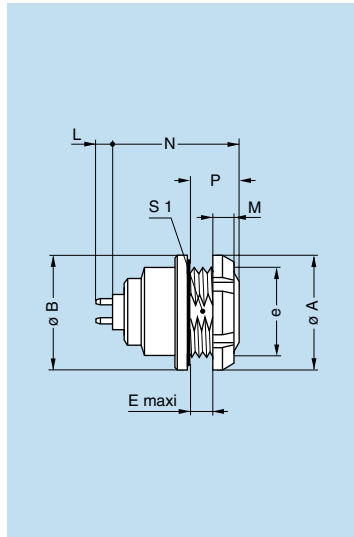

### EEG Fixed receptacle, nut fixing, key (G) or keys (A to F and R) and straight contacts for printed circuit (back panel mounting)

Reference		Dimensions (mm)									Availability
Model	Series	A	B	e	E	M	N	P	S1		
EEG	0K	18.0	18	M14x1.0	3.4	3.5	17.6	7.0	12.5	○	
EEG	1K	20.0	20	M16x1.0	6.2	3.5	23.8	10.0	14.5	○	
EEG	2K	25.0	25	M20x1.0	5.0	3.5	25.8	10.0	18.5	○	
EEG	3K	30.0	31	M24x1.0	7.5	4.5	31.3	12.0	22.5	○	
EEG	4K	41.5	37	M30x1.0	6.0	7.0	34.3	13.5	28.5	○	

Panel cut-out: **P1**

PCB drilling pattern: **P15**

**Note:** This contact type is available for E•• receptacle models fitted with female contact.  
Length «L» depends on the number of contacts, see table page 106  
The 3K and 4K series are delivered with a conical nut.

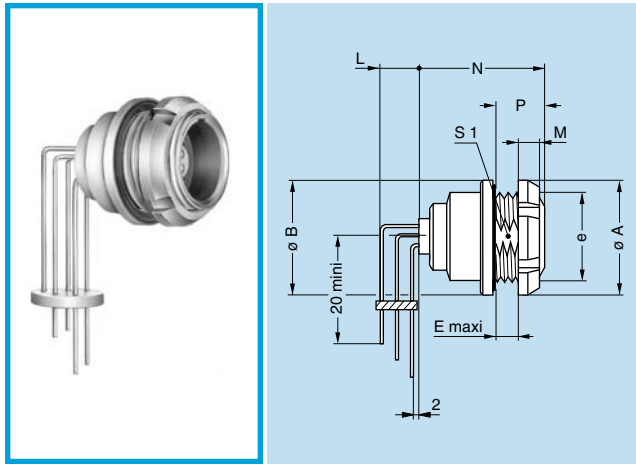

**EEG** Fixed receptacle, nut fixing, key (G) or keys (A to F and R) with elbow (90°) contacts for printed circuit (back panel mounting)

Reference		Dimensions (mm)								Availability
Model	Series	A	B	e	E	M	N	P	S1	
EEG	0K	18	18	M14x1.0	3.4	3.5	19.3	7	12.5	○
EEG	1K	20	20	M16x1.0	6.2	3.5	24.3	10	14.5	○
EEG	2K	25	25	M20x1.0	5.0	3.5	26.6	10	18.5	○
EEG	3K	30	31	M24x1.0	7.5	4.5	31.3	12	22.5	○

Panel cut-out: **P1**

PCB drilling pattern: **P17**

**Note:** Length «L» depends on the number of contacts, see PCB drilling pattern page 107.  
The 3K series is delivered with a conical nut.

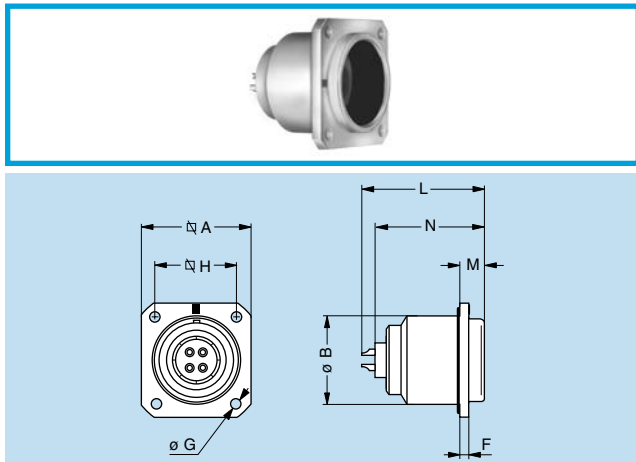

**EBG** Fixed receptacle with square flange, key (G) or keys (A to F, L and R) and screw fixing

Reference		Dimensions (mm)								Availability
Model	Series	A	B	F	G	H	L	M	N <sup>1)</sup>	
EBG	3K	29	23	3	3.4	23	36.2	6.0	32.6	○
EBG	4K	37	30	3	3.4	29	40.2	6.5	36.6	○
EBG	5K	54	45	4	4.4	44	47.5	8.0	42.1	○

Panel cut-out: **P7**

**Note:** <sup>1)</sup> Maximum length with crimp contacts.

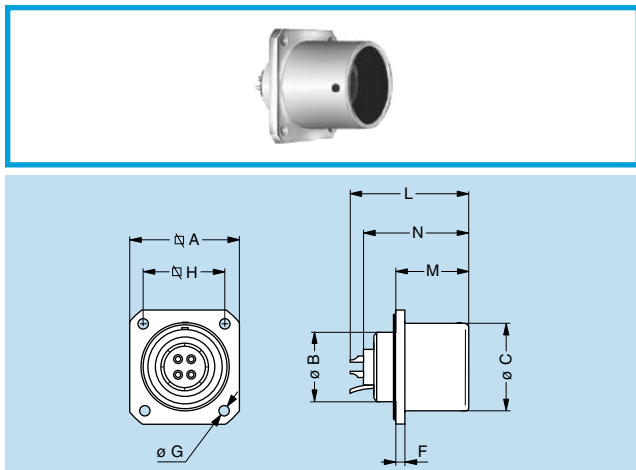

**EDG** Fixed receptacle with square flange, key (G) or keys (A to F, L and R), protruding shell and grounding tab, screw fixing

Reference		Dimensions (mm)								Availability	
Model	Series	A	B	C	F	G	H	L	M		N <sup>1)</sup>
EDG	3K	29	18	23	3	3.4	23	36.2	22.5	32.6	○

Panel cut-out: **P7**

**Note:** <sup>1)</sup> Maximum length with crimp contacts.

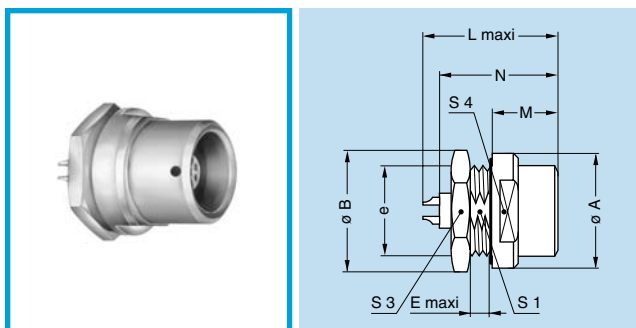

**EHG** Fixed receptacle, nut fixing, key (G) or keys (A to F and L), protruding shell

Reference		Dimensions (mm)								Availability	
Model	Series	A	B	e	E	L	M	N <sup>1)</sup>	S1		S3
EHG	1K	20	21.5	M16x1.0	1.5	27.0	15.5	25.1	14.5	19	17
EHG	2K	25	27.5	M20x1.0	1.5	30.7	17.0	27.1	18.5	24	20

Panel cut-out: **P1**

**Note:** <sup>1)</sup> Maximum length with crimp contacts.

● Standard, typically 0-6 weeks delivery for quantities of 250 or less.  
○ Non-standard product, contact LEMO USA, typically 6-12 weeks delivery for quantities of 250 or less.  
Non-standard product is defined as any product which contains one or more components which are not standard.

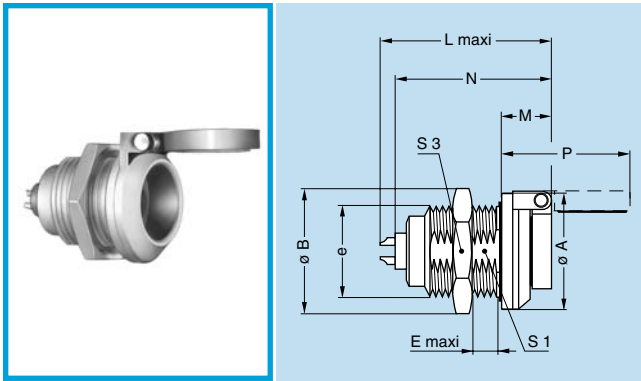

### EVG Fixed receptacle, nut fixing, key (G) or keys (A to F and L) and dust cap (spring loaded)

Reference		Dimensions (mm)										Availability
Model	Series	A	B	e	E	L	M	N <sup>1)</sup>	P	S1	S3	
EVG	0K	18	19.5	M14x1.0	6	24.8	7.2	23.3	21.6	12.5	17	○

Panel cut-out: **P1**

**Note:** 1) Maximum length with crimp contacts.

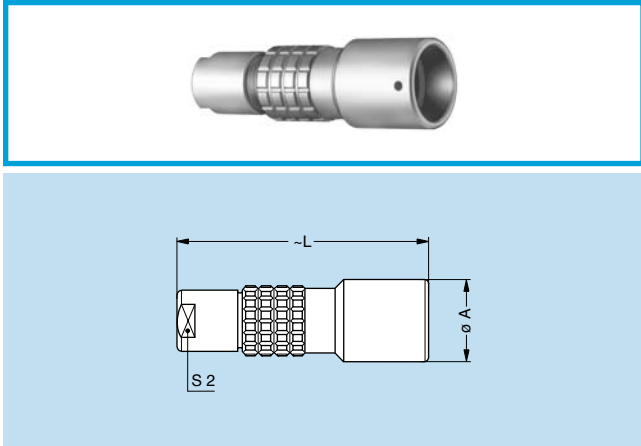

### PHG Free receptacle, key (G) or keys (A to F, L and R), cable collet

Reference		Dimensions (mm)			Availability
Model	Series	A	L	S2	
PHG	0K	13	34.0	8	●
PHG	1K	15	45.0	9	●
PHG	2K	19	54.0	12	○
PHG	3K	23	65.0	15	○
PHG	4K	29	75.5	19	○
PHG	5K	42	95.0	32	○

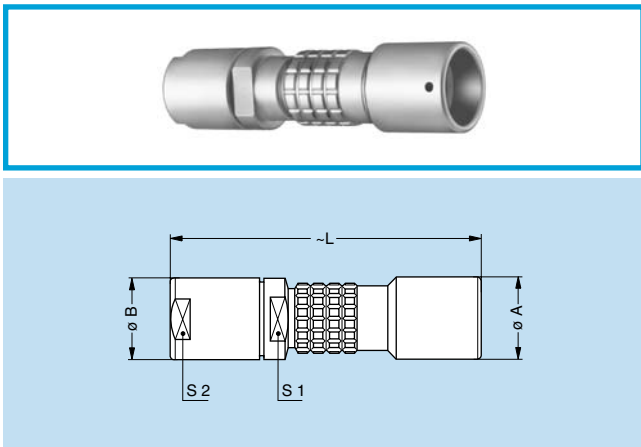

### PHG Free receptacle, key (G) or keys (A to F, L and R), with oversize cable collet

Reference		Dimensions (mm)					Availability
Model	Series	A	B	L	S1	S2	
PHG	1K	15	14.5	58	12	12	○
PHG	2K	19	17.0	67	15	15	○
PHG	3K	23	22.0	84	19	19	○
PHG	4K	29	36.0	109	30	32	○

**Note:** The fitting of oversize collets onto this model allows them to be fitted to the cables that can be accommodated by the next housing size up.

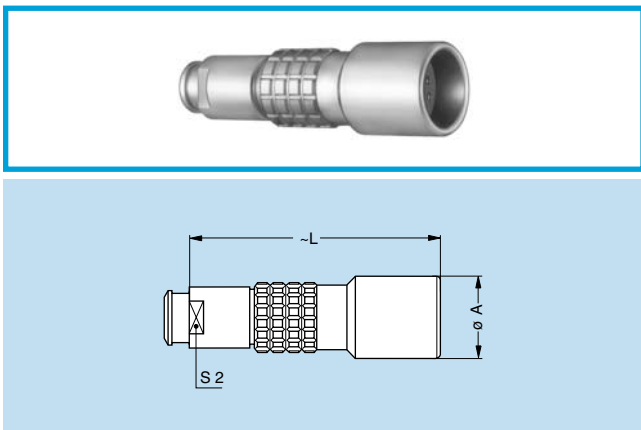

### PHG Free receptacle, key (G) or keys (A to F, L and R), cable collet and nut for fitting a bend relief

Reference		Dimensions (mm)			Availability
Model	Series	A	L	S2	
PHG	0K	13	34.0	7	●
PHG	1K	15	45.0	9	●
PHG	2K	19	54.0	12	○
PHG	3K	23	64.0	15	○
PHG	4K	29	75.5	19	○

**Note:** The bend relief must be ordered separately (see page 91).



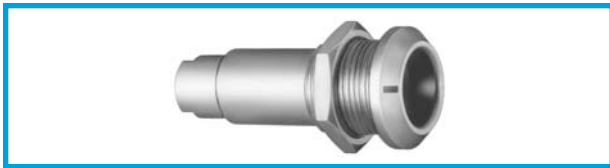

**PKG Fixed receptacle, nut fixing, key (G) or keys (A to F, L and R), cable collet**

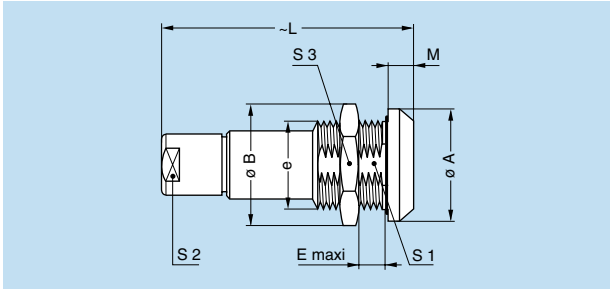

Reference		Dimensions (mm)									Availability
Model	Series	A	B	e	E	L	M	S1	S2	S3	
PKG	0K	18	19.5	M14x1.0	6	34.0	4.0	12.5	8	17	○
PKG	1K	20	21.5	M16x1.0	9	45.0	4.5	14.5	9	19	○
PKG	2K	25	27.5	M20x1.0	9	54.0	5.0	18.5	12	24	○
PKG	3K	31	34.5	M24x1.0	11	65.0	6.0	22.5	15	30	○
PKG	4K	37	40.5	M30x1.0	9	75.5	6.5	28.5	19	36	○
PKG	5K	55	54.0	M45x1.0	15	98.0	9.0	42.5	30	-	○

Panel cut-out: **P1**

**Note:** The 5K series is delivered with a round nut.

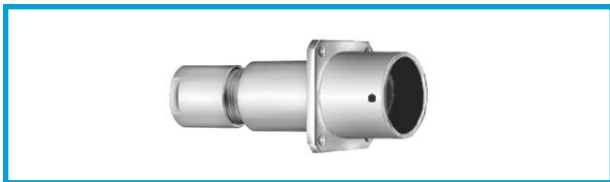

**PBG Fixed receptacle, key (G) with square flange, cable collet and screw fixing**

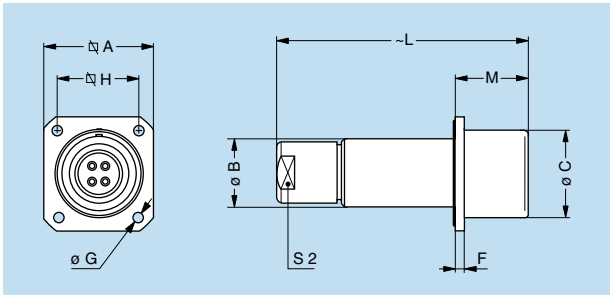

Reference		Dimensions (mm)									Availability
Model	Series	A	B	C	F	G	H	L	M	S2	
PBG	3K	29	19	23	3	3.4	23	65	22.5	15	○

Panel cut-out: **P7**

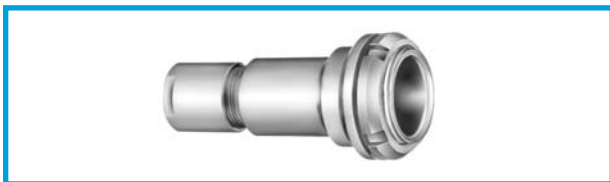

**PEG Fixed receptacle, nut fixing, key (G) or keys (A to F, L and R), cable collet (back panel mounting)**

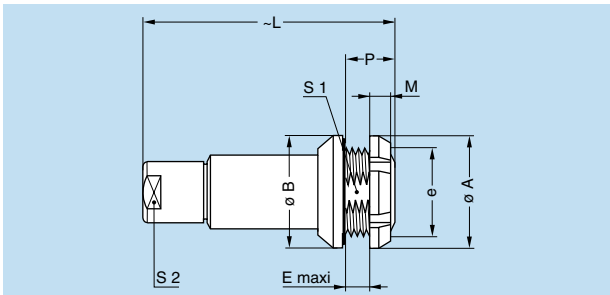

Reference		Dimensions (mm)									Availability
Model	Series	A	B	e	E	L	M	P	S1		
PEG	0K	18	18	M14x1.0	5.0	34	3.5	8.5	12.5	○	
PEG	1K	20	20	M16x1.0	6.5	45	3.5	10	14.5	○	
PEG	2K	25	25	M20x1.0	4.0	54	3.5	7.5	18.5	○	
PEG	3K	30	31	M24x1.0	7.5	65	4.5	12	22.5	○	

Panel cut-out: **P1**

**Note:** The 3K series is delivered with a conical nut.

● Standard, typically 0-6 weeks delivery for quantities of 250 or less.  
 ○ Non-standard product, contact LEMO USA, typically 6-12 weeks delivery for quantities of 250 or less.  
 Non-standard product is defined as any product which contains one or more components which are not standard.

## Model with microswitch

Some receptacles are available fitted with a microswitch. The microswitch is independent from the electrical contacts of the receptacle. The introduction of a plug into the receptacle activates the microswitch.

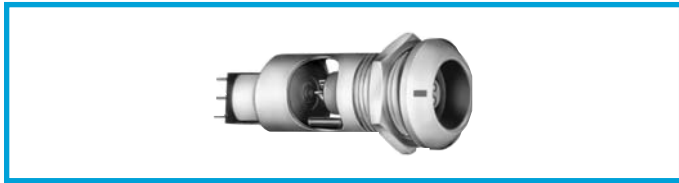

### EMG Fixed receptacle, nut fixing, with microswitch, key (G) or keys (A to F and L)

Reference		Dimensions (mm)								Availability
Model	Series	A	B	e	E	L	M	S1	S3	
EMG	2K	25	27.5	M20x1.0	9	49	5	18.5	24	○

Panel cut-out: **P1**

**Note:** For the microswitch – maximum operating voltage: 270 Veff/Vdc;  
– rated current: 8.5A/0.5A.

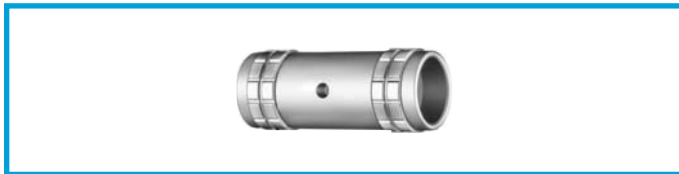
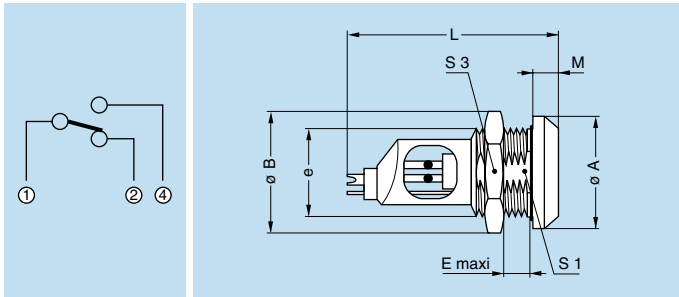

### TGL Free coupler, key (G) on one side and keys (L) on the other

Reference		Dim. (mm)		Availability
Model	Series	A	L	
TGL	3K	24	64.2	○

**Note:** This model is only available in type 308, 310, 316, 318, 320 and 324.

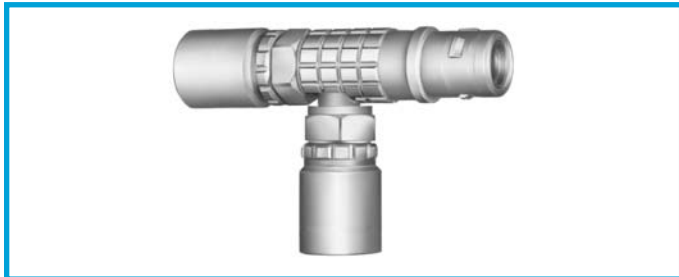
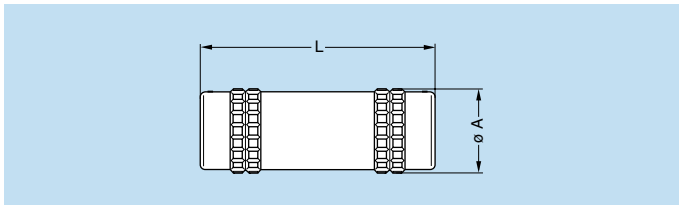

### FTG T-plug, key (G) with receptacles (90°), key (G)

Reference		Dimensions (mm)					Availability
Model	Series	A	B	H	L	M	
FTG	2K	16	19	48	77	60	○

**Note:** This model is only available in type 304.

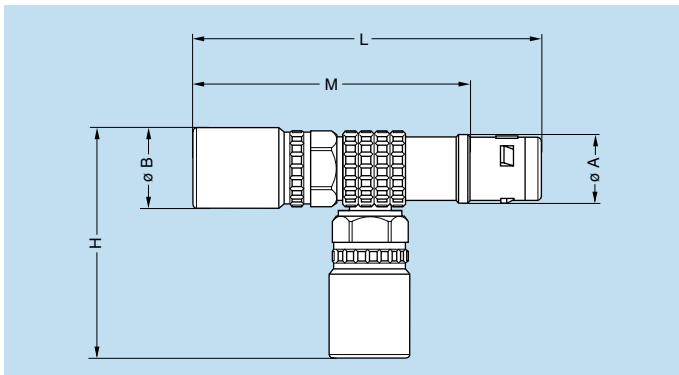

● Standard, typically 0-6 weeks delivery for quantities of 250 or less.  
○ Non-standard product, contact LEMO USA, typically 6-12 weeks delivery for quantities of 250 or less.  
Non-standard product is defined as any product which contains one or more components which are not standard.

## Watertight or vacuum-tight models

HEG, HGG and S●● receptacle or coupler models allow the device on which they are fitted to reach a protection index of IP68 as per IEC 60529. They are fully compatible with plugs of the same series and are widely used for portable radios, military, laboratory equipment, aviation, etc. These models are identified by a letter «P» at the end of the reference. Most of these models are also available in a vacuum-tight version. Such models are identified by an additional letter «V» at the end of the part number (certificate on request).

Epoxy resin is used to seal these models.

Part number example:  
 Watertight receptacle – HGG.0K.304.CLLP  
 Vacuum-tight receptacle – HGG.0K.304.CLLPV

## Technical Characteristics

### Mechanical and Climatic

Characteristics	Value	Standard
Endurance	> 5000 cycles	IEC 60512-5 test 9a
Humidity	up to 95% at 140° F	
Temperature range	-4° F/+176° F	
Salt spray corrosion test	> 144h	IEC 60512-6 test 11f
Protection index (mated)	IP 68	
Climatic category	20/80/21	IEC 60068-1
Leakage rate (He) <sup>1)</sup>	< 10 <sup>-7</sup> mbar.l.s <sup>-1</sup>	IEC 60512-7 test 14b
Maximum operating pressure <sup>2)</sup>	0K	60 bars
	1K	60 bars
	2K	40 bars
	3K	30 bars
	4K	15 bars
	5K	5 bars
		IEC 60512-7 test 14d

**Note:**

- 1) Only for vacuum-tight models.
- 2) This value corresponds to the maximum allowed pressure difference for the assembled receptacle.

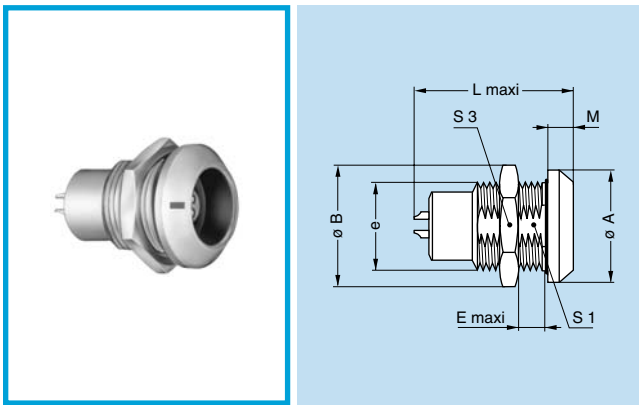

### HGG Fixed receptacle, nut fixing, key (G) or keys (A to F and L), watertight or vacuum-tight

Reference		Dimensions (mm)								Availability
Model	Series	A	B	e	E	L	M	S1	S3	
HGG	0K	18	19.5	M14x1.0	5.5	21.7	4.0	12.5	17	○
HGG	1K	20	21.5	M16x1.0	9.0	30.0	4.5	14.5	19	○
HGG	2K	25	27.5	M20x1.0	13.0	33.7	5.0	18.5	24	○
HGG	5K	55	54.0	M45x1.5	10.0	55.7	9.0	42.5	–	○

Panel cut-out: **P1**

**Note:** The 5K series is delivered with a round nut.

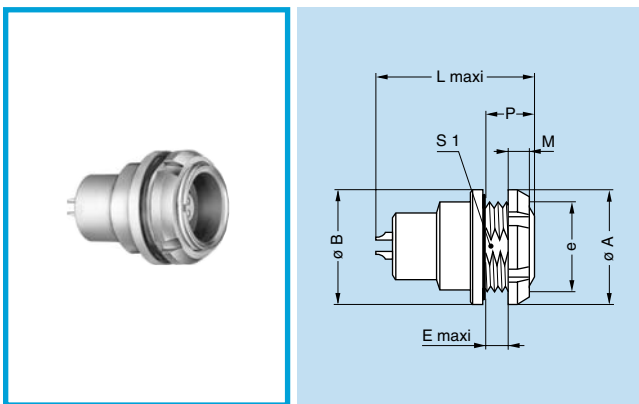

### HEG Fixed receptacle, nut fixing, key (G) or keys (A to F and L), watertight or vacuum-tight (back panel mounting)

Reference		Dimensions (mm)								Availability
Model	Series	A	B	e	E	L	M	P	S1	
HEG	0K	18	18	M14x1.0	2.4	21.7	3.5	7	12.5	○
HEG	1K	20	20	M16x1.0	6.2	30.0	3.5	10	14.5	○
HEG	2K	25	25	M20x1.0	5.0	33.7	3.5	10	18.5	○

Panel cut-out: **P1**

● Standard, typically 0-6 weeks delivery for quantities of 250 or less.  
 ○ Non-standard product, contact LEMO USA, typically 6-12 weeks delivery for quantities of 250 or less.  
 Non-standard product is defined as any product which contains one or more components which are not standard.

**S●● Fixed coupler, nut fixing, key (G) or keys (L) at the flange end, and key (G) or keys (C or L) at the other end, watertight or vacuum-tight**

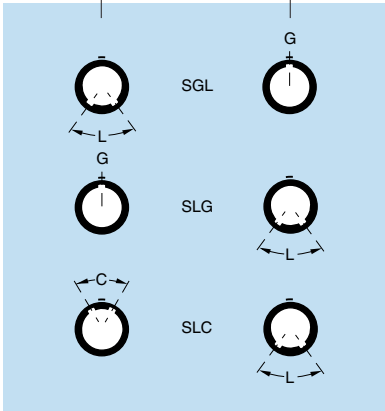
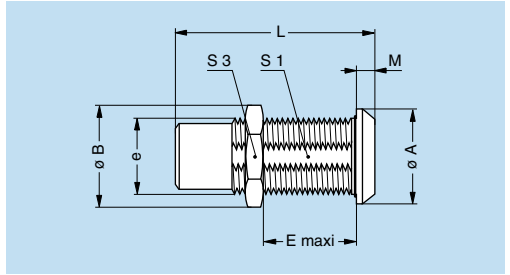
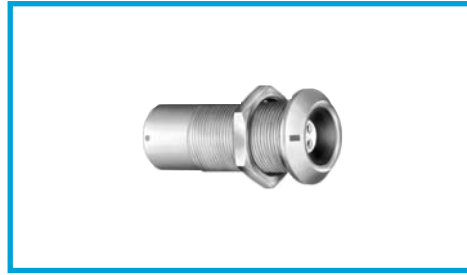
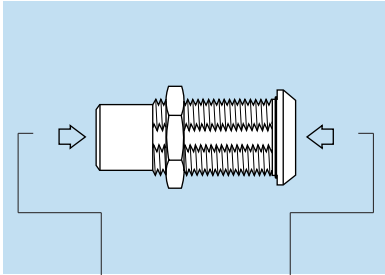

Reference		Contacts Type	Dimensions (mm)								Avail- ability
Model	Series		A	B	e	E	L	M	S1	S3	
SGL	2K	female – male	25	27.5	M20x1.0	25	52.4	5.0	18.5	24	○
SLG	4K	male – female	37	40.0	M30x1.0	48	74.0	6.5	28.5	36	○
SLC											
SLC	5K	male – female	55	54.0	M45x1.5	58	88.0	9.0	42.5	–	○

Panel cut-out: **P1**

**Note:** For this fixed coupler, the first contact type mentioned is always the one at the flange end. On request, these couplers can be produced in other series. With other keys, the 5K series is delivered with a round nut.

# • Type

## Multicontact

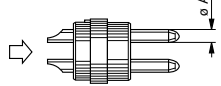
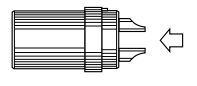
	 Male solder contacts  Female solder contacts		Reference	Number of contacts	Solder				Crimp		Contact type		Solder contact		Crimp contact		Rated current (A) <sup>1)</sup>	
	AWG max. (solid)	AWG max. (stranded)			AWG min. (stranded)	AWG max. (stranded)	Solder	Crimp	Printed circuit (straight)	Printed circuit (elbow)	Test voltage (kV rms) <sup>1)</sup> Contact-contact	Test voltage (kV rms) <sup>1)</sup> Contact-shell	Test voltage (kV rms) <sup>1)</sup> Contact-contact	Test voltage (kV rms) <sup>1)</sup> Contact-shell				
OK			302	2	0.9	22	22 <sup>4)</sup>	24	20	○	○	○	○	1.30	1.05	1.45	1.20	10.0 <sup>3)</sup>
			303	3	0.9	22	22 <sup>4)</sup>	24	20	○	○	○	○	1.20	0.90	1.70	1.60	8.0 <sup>2)</sup>
			304	4	0.7	22	22 <sup>4)</sup>	26	22 <sup>4)</sup>	○	○	○	○	0.85	0.70	1.35	1.10	7.0 <sup>2)</sup>
			305	5	0.7	22	22 <sup>4)</sup>	26	22 <sup>4)</sup>	○	○	○	○	1.00	0.70	1.25	1.20	6.5 <sup>2)</sup>
			306	6	0.5	28	28	32	28	○	○	○	○	0.85	0.65	1.40	1.20	2.5
			307	7	0.5	28	28	32	28	○	○	○	○	0.80	0.70	1.40	1.20	2.5
			309	9	0.5	28	28	32	28	○	○	○	○	0.60	0.50	1.00	0.85	2.0
	1K			302	2	1.3	20	20 <sup>4)</sup>	20	18	○	○	○	○	1.50	1.35	1.70	1.45
			303	3	1.3	20	20 <sup>4)</sup>	20	18	○	○	○	○	1.30	1.55	1.60	1.85	12.0
			304	4	0.9	22	22 <sup>4)</sup>	24	20	●	●	○	○	1.35	1.45	1.70	1.80	10.0 <sup>3)</sup>
			305	5	0.9	22	22 <sup>4)</sup>	24	20	○	○	○	○	1.25	1.15	1.30	1.55	9.0 <sup>2)</sup>
			306	6	0.7	22	22 <sup>4)</sup>	26	22 <sup>4)</sup>	○	○	○	○	1.05	1.20	1.35	1.45	7.0 <sup>2)</sup>
			307	7	0.7	22	22 <sup>4)</sup>	26	22 <sup>4)</sup>	○	○	○	○	0.95	1.05	1.45	1.45	7.0 <sup>2)</sup>
			308	8	0.7	22	22 <sup>4)</sup>	26	22 <sup>4)</sup>	○	○	○	○	0.95	1.15	1.30	1.30	5.0
			310	10	0.5	28	28	-	-	○	-	○	○	0.90	1.50	1.20	1.80	2.5
			314	14	0.5	28	28	-	-	○	-	○	○	0.80	1.20	0.95	1.60	2.0
			316	16	0.5	28	28	-	-	○	-	○	○	0.80	1.25	0.95	1.60	1.5

**Note:** 1) See calculation method, caution and suggested standard on page 11.  
 2) Rated current = 6A for receptacle with elbow (90°) contact for printed circuit.  
 3) Rated current = 12A for receptacle with elbow (90°) contact for printed circuit.  
 4) For a given AWG, the diameter of some stranded conductor designs is larger than the solder cup diameter. Make sure that the maximum conductor diameter is smaller than øC on page 9 (for solder), and page 10 (for crimp).

● Standard, typically 0-6 weeks delivery for quantities of 250 or less.  
 ○ Non-standard product, contact LEMO USA, typically 6-12 weeks delivery for quantities of 250 or less.  
 Non-standard product is defined as any product which contains one or more components which are not standard.

## Multicontact

		Reference	Number of contacts	ø A (mm)	Solder		Crimp		Contact type		Solder contact		Crimp contact		Rated current (A) <sup>1)</sup>		
Male solder contacts	Female solder contacts				AWG max. (solid)	AWG max. (stranded)	AWG min. (stranded)	AWG max. (stranded)	Solder	Crimp	Printed circuit (straight)	Printed circuit (elbow)	Test voltage (kV rms) <sup>1)</sup> Contact-contact	Test voltage (kV rms) <sup>1)</sup> Contact-shell		Test voltage (kV rms) <sup>1)</sup> Contact-contact	Test voltage (kV rms) <sup>1)</sup> Contact-shell
Male crimp contacts	Female crimp contacts																
2K		302	2	2.0	14	16	16	12 <sup>4)</sup>	○	○	○	○	2.10	1.75	2.85	2.70	30.0 <sup>3)</sup>
		303	3	1.6	16	18	18	14 <sup>4)</sup>	○	○	○	○	2.40	1.85	1.90	1.90	17.0 <sup>3)</sup>
		304	4	1.3	20	20 <sup>4)</sup>	20	18	○	○	○	○	1.85	1.85	2.20	2.20	15.0 <sup>3)</sup>
		305	5	1.3	20	20 <sup>4)</sup>	20	18	○	○	○	○	1.75	1.60	2.15	2.15	14.0 <sup>3)</sup>
		306	6	1.3	20	20 <sup>4)</sup>	20	18	○	○	○	○	1.35	1.45	2.00	2.35	12.0
		307	7	1.3	20	20 <sup>4)</sup>	20	18	○	○	○	○	1.75	1.60	1.95	2.15	11.0
		308	8	0.9	22	22 <sup>4)</sup>	24	20	○	○	○	○	1.50	1.25	1.95	1.95	10.0 <sup>3)</sup>
		310	10	0.9	22	22 <sup>4)</sup>	24	20	○	○	○	○	1.45	1.30	1.80	2.10	8.0 <sup>3)</sup>
		312	12	0.7	22	22 <sup>4)</sup>	26	22 <sup>4)</sup>	○	○	○	○	1.25	1.35	1.65	2.00	7.0 <sup>3)</sup>
		314	14	0.7	22	22 <sup>4)</sup>	26	22 <sup>4)</sup>	○	○	○	○	1.15	1.35	1.55	1.95	6.5 <sup>3)</sup>
		316	16	0.7	22	22 <sup>4)</sup>	26	22 <sup>4)</sup>	○	○	○	○	0.95	1.25	1.55	1.75	6.0
		318	18	0.7	22	22 <sup>4)</sup>	26	22 <sup>4)</sup>	○	○	○	○	0.85	1.20	1.45	2.10	5.5
		319	19	0.7	22	22 <sup>4)</sup>	26	22 <sup>4)</sup>	○	○	○	○	0.95	1.25	1.55	1.65	5.0
		326	26	0.5	28	28	-	-	○	-	○	-	0.95	1.30	1.20	1.80	2.0
		332	32	0.5	28	28	-	-	○	-	○	-	0.80	1.2	0.95	1.60	1.5

Note: <sup>1)</sup> See calculation method, caution and suggested standard on page 11.

<sup>2)</sup> Rated current = 6A for receptacle with elbow (90°) contact for printed circuit.

<sup>3)</sup> Rated current = 12A for receptacle with elbow (90°) contact for printed circuit.











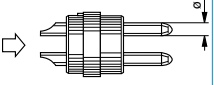
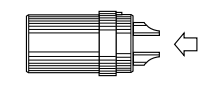



























<sup>4)</sup> For a given AWG, the diameter of some stranded conductor designs is larger than the solder cup diameter. Make sure that the maximum conductor diameter is smaller than øC on page 9 (for solder), and page 10 (for crimp).

● Standard, typically 0-6 weeks delivery for quantities of 250 or less.

○ Non-standard product, contact LEMO USA, typically 6-12 weeks delivery for quantities of 250 or less.

Non-standard product is defined as any product which contains one or more components which are not standard.

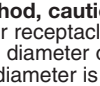
### Multicontact

	 Male solder contacts  Female solder contacts		Reference	Number of contacts	ø A (mm)	Solder		Crimp		Contact type				Solder contact		Crimp contact		Rated current (A) <sup>1)</sup>
	AWG max. (solid)	AWG max. (stranded)				AWG min. (stranded)	AWG max. (stranded)	Solder	Crimp	Printed circuit (straight)	Printed circuit (elbow)	Test voltage (kV rms) <sup>1)</sup> Contact-contact	Test voltage (kV rms) <sup>1)</sup> Contact-shell	Test voltage (kV rms) <sup>1)</sup> Contact-contact	Test voltage (kV rms) <sup>1)</sup> Contact-shell			
<b>3K</b>			302	2	3.0	10	12	14	10 <sup>3)</sup>	○	○	○	–	2.10	1.55	2.30	1.80	35.0
			303	3	2.0	14	16	16	12 <sup>3)</sup>	○	○	○	–	1.90	1.50	3.20	2.65	25.0
			304	4	2.0	14	16	16	12 <sup>3)</sup>	○	○	○	–	1.45	1.25	2.50	2.20	19.0
			305	5	1.6	16	18	18	14 <sup>3)</sup>	○	○	○	–	1.90	1.25	2.40	1.75	19.0
			306	6	1.6	16	18	18	14 <sup>3)</sup>	○	○	○	–	1.60	1.15	1.90	1.80	17.0
			307	7	1.6	16	18	18	14 <sup>3)</sup>	○	○	○	–	1.70	1.25	2.00	2.05	15.0
			308	8	1.3	20	20 <sup>3)</sup>	20	18	○	○	○	○	1.65	1.15	1.85	1.75	13.0
			309	8	1.3	20	20 <sup>3)</sup>	20	18	○	○	○	–	1.35	1.05	1.10	1.05	6.0
				1	2.0	14	16	16	12 <sup>3)</sup>	○	○	○	–	1.35	1.05	1.10	1.05	15.0
			310	10	1.3	20	20 <sup>3)</sup>	20	18	○	○	○	○	1.25	0.90	1.50	1.80	12.0
			312	12	0.9	22	22 <sup>3)</sup>	24	20	○	○	○	○	1.45	1.00	1.65	1.85	9.0
			314	14	0.9	22	22 <sup>3)</sup>	24	20	○	○	○	○	1.20	1.20	1.80	1.65	9.0 <sup>2)</sup>
			316	16	0.9	22	22 <sup>3)</sup>	24	20	○	○	○	○	1.20	0.85	1.80	1.50	8.0
			318	18	0.9	22	22 <sup>3)</sup>	24	20	○	○	○	○	1.20	1.05	1.85	1.60	7.0
			320	20	0.7	22	22 <sup>3)</sup>	26	22 <sup>3)</sup>	○	○	○	○	1.00	0.90	1.35	1.55	6.0
			322	22	0.7	22	22 <sup>3)</sup>	26	22 <sup>3)</sup>	○	○	○	○	1.00	0.90	1.70	1.45	5.5
			324	24	0.7	22	22 <sup>3)</sup>	26	22 <sup>3)</sup>	○	○	○	○	0.95	0.80	1.35	1.35	4.0
		326	26	0.7	22	22 <sup>3)</sup>	26	22 <sup>3)</sup>	○	○	○	○	0.95	0.70	1.50	1.30	4.0	
		330	30	0.7	22	22 <sup>3)</sup>	26	22 <sup>3)</sup>	○	○	○	○	0.80	0.70	1.35	1.20	3.5	

Note: 1) See calculation method, caution and suggested standard on page 11.

2) Rated current = 6A for receptacle with elbow (90°) contact for printed circuit.











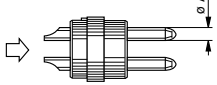
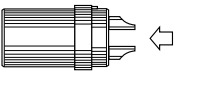
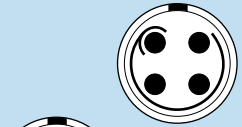
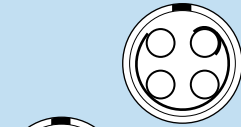

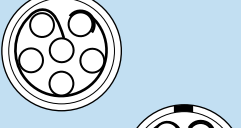

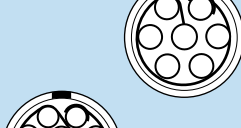

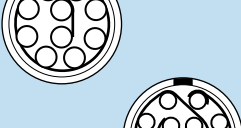
3) For a given AWG, the diameter of some stranded conductor designs is larger than the solder cup diameter. Make sure that the maximum conductor diameter is smaller than øC on page 9 (for solder), and page 10 (for crimp).

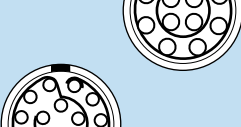
● Standard, typically 0-6 weeks delivery for quantities of 250 or less.

○ Non-standard product, contact LEMO USA, typically 6-12 weeks delivery for quantities of 250 or less.

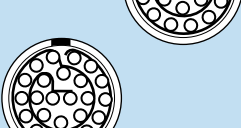
Non-standard product is defined as any product which contains one or more components which are not standard.

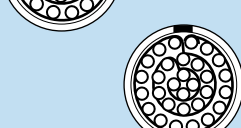
## Multicontact

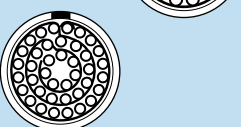
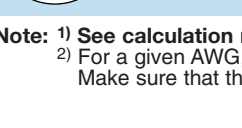
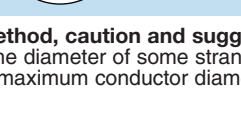









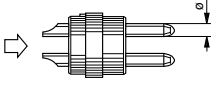
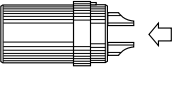
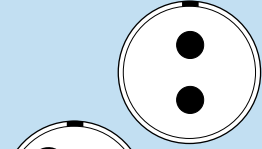
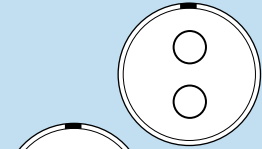
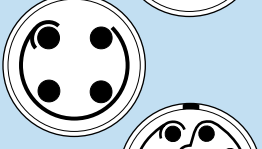
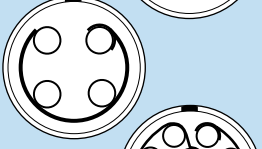

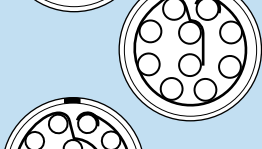
	 Male solder contacts		 Female solder contacts		Reference	Number of contacts	ø A (mm)	Solder		Crimp		Contact type			Solder contact		Crimp contact		Rated current (A) <sup>1)</sup>
	AWG max. (solid)	AWG max. (stranded)	AWG min. (stranded)	AWG max. (stranded)				Solder	Crimp	Printed circuit (straight)	Test voltage (kV rms) <sup>1)</sup> Contact-contact	Test voltage (kV rms) <sup>1)</sup> Contact-shell	Test voltage (kV rms) <sup>1)</sup> Contact-contact	Test voltage (kV rms) <sup>1)</sup> Contact-shell					
<b>4K</b>			304	4	3.0	10	12	14	10 <sup>2)</sup>	○	○	○	2.10	1.50	1.80	1.20	30.0		
			306	6	2.0	14	16	16	12 <sup>2)</sup>	○	○	○	2.00	1.75	2.75	2.40	24.0		
			307	7	2.0	14	16	16	12 <sup>2)</sup>	○	○	○	2.00	1.80	1.50	1.35	20.0		
			310	10	1.6	16	18	18	14 <sup>2)</sup>	○	○	○	1.85	1.30	1.90	1.95	17.0		
			312	12	1.3	20	20 <sup>2)</sup>	20	18	○	○	○	1.45	1.60	1.90	1.85	12.0		
			316	16	0.9	22	22 <sup>2)</sup>	24	20	○	○	○	1.35	1.50	2.30	2.10	10.0		
			320	20	0.9	22	22 <sup>2)</sup>	24	20	○	○	○	1.35	1.00	1.05	0.95	8.0		
			324	24	0.9	22	22 <sup>2)</sup>	24	20	○	○	○	1.20	1.45	1.80	2.05	7.0		
			330	30	0.9	22	22 <sup>2)</sup>	24	20	○	○	○	0.95	0.85	1.75	1.45	5.0		
			340	40	0.7	22	22 <sup>2)</sup>	26	22 <sup>2)</sup>	○	○	○	0.90	0.95	1.35	1.30	2.0		

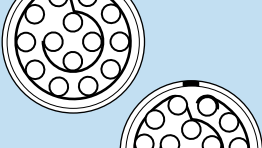
**Note:** <sup>1)</sup> See calculation method, caution and suggested standard on page 11.

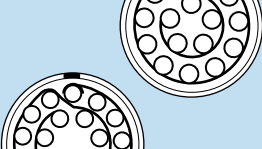
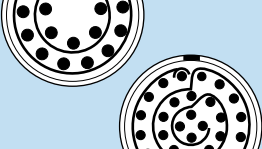
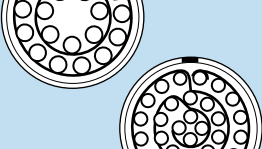
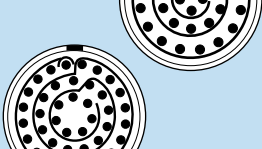
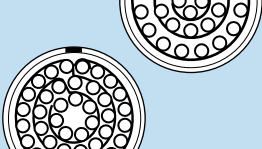
<sup>2)</sup> For a given AWG, the diameter of some stranded conductor designs is larger than the solder cup diameter. Make sure that the maximum conductor diameter is smaller than øC on page 9 (for solder), and page 10 (for crimp).

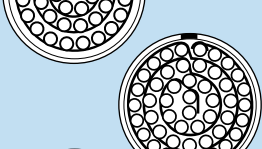
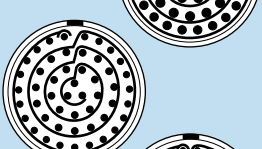
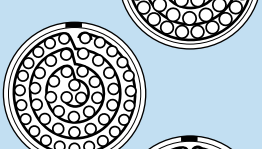

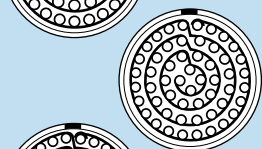
## Multicontact

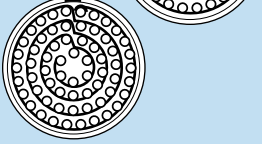
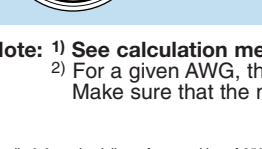
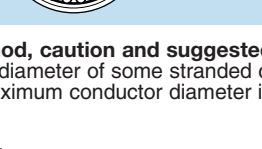
	 Male solder contacts		 Female solder contacts		Reference	Number of contacts		Solder		Crimp		Contact type			Solder contact		Crimp contact		Rated current (A) <sup>1)</sup>
	Male crimp contacts	Female crimp contacts	ø A (mm)	AWG max. (solid)		AWG max. (stranded)	AWG min. (stranded)	AWG max. (stranded)	Solder	Crimp	Printed circuit (straight)	Test voltage (kV rms) <sup>1)</sup> Contact-contact	Test voltage (kV rms) <sup>1)</sup> Contact-shell	Test voltage (kV rms) <sup>1)</sup> Contact-contact	Test voltage (kV rms) <sup>1)</sup> Contact-shell				
<b>5K</b>			2	6.0	-	8	-	-	○	-	-	3.60	2.95	-	-	50.0			
			4	4.0	10	10	12	10 <sup>2)</sup>	○	○	○	2.95	2.65	3.20	2.40	35.0			
			10	3.0	10	12	14	10 <sup>2)</sup>	○	○	○	2.35	2.30	2.65	3.20	20.0			
			14	2.0	14	16	16	12 <sup>2)</sup>	○	○	○	2.10	2.00	2.85	2.95	18.0			
			16	2.0	14	16	16	12 <sup>2)</sup>	○	○	○	1.85	1.95	2.45	3.05	12.0			
			20	1.6	16	18	18	14 <sup>2)</sup>	○	○	○	1.90	1.70	2.20	2.40	10.0			
			30	1.3	20	20 <sup>2)</sup>	20	18	○	○	○	1.45	1.60	2.05	2.45	8.0			
			40	1.3	20	20 <sup>2)</sup>	20	18	○	○	○	1.30	1.45	2.00	1.95	7.0			
			48	1.3	20	20 <sup>2)</sup>	20	18	○	○	○	1.20	1.10	2.00	1.55	6.0			
			50	0.9	22	22 <sup>2)</sup>	24	20	○	○	○	1.30	1.60	1.20	1.45	6.0			
			54	0.9	22	22 <sup>2)</sup>	24	20	○	○	○	1.15	1.55	2.00	2.10	5.0			
			64	0.9	22	22 <sup>2)</sup>	24	20	○	○	○	1.30	1.55	1.35	1.85	3.0			

Note: 1) See calculation method, caution and suggested standard on page 11.

2) For a given AWG, the diameter of some stranded conductor designs is larger than the solder cup diameter.











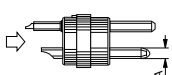
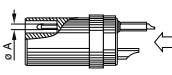
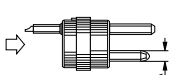
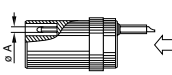









Make sure that the maximum conductor diameter is smaller than øC on page 9 (for solder), and page 10 (for crimp).

● Standard, typically 0-6 weeks delivery for quantities of 250 or less.

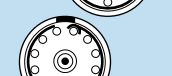
○ Non-standard product, contact LEMO USA, typically 6-12 weeks delivery for quantities of 250 or less.

Non-standard product is defined as any product which contains one or more components which are not standard.

## Mixed (High Voltage + Low Voltage)

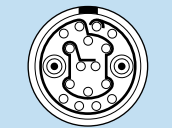
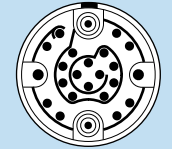
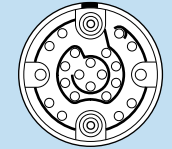
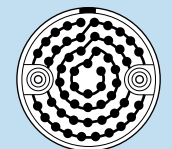
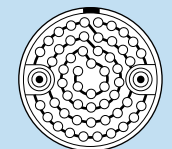
	 		Reference	High voltage								Low voltage												
	 			Number of contacts	Contact ø A (mm)	Contact type <sup>1)</sup>	HV contact gender with key «G» <sup>2)</sup>	Conductor AWG max.	Cable dielectric ø max. (mm)	Standard insulator material <sup>3)</sup>	Test voltage (kV dc) <sup>4)</sup>	Rated current (A) <sup>1)</sup>	Number of contacts	Contact ø A (mm)	AWG max. (Stranded/Solder)	AWG min. (Stranded/Crimp)	AWG max. (Stranded/Crimp)	Contact type		Solder contact		Crimp contact		Rated current (A) <sup>4)</sup>
	Solder	Crimp																Test voltage (kV rms) <sup>4)</sup> Contact-contact	Test voltage (kV rms) <sup>4)</sup> Contact-shell	Test voltage (kV rms) <sup>4)</sup> Contact-contact	Test voltage (kV rms) <sup>4)</sup> Contact-shell			
1K	 		702	1	0.7	S	L	26	1.5	L	7.5	2	2	1.3	20 <sup>5)</sup>	20	18	○	○	1.2	0.9	0.6	0.50	8
	 		731	2	0.7	S	L	26	1.5	L	7.5	2	1	1.3	20 <sup>5)</sup>	20	18	○	○	1.2	0.9	0.6	0.50	8
2K	 		704	1	1.3	S	L	20 <sup>5)</sup>	3.4	L/T	7.5	8	4	0.7	22 <sup>5)</sup>	26	22 <sup>5)</sup>	○	○	0.85	1.2	0.6	1.0	5
	 		706	1	0.7	S	L	26	2.0	L	7.5	3	6	1.3	20 <sup>5)</sup>	20	18	○	○	1.75	1.6	1.05	1.15	11
	 		708	1	0.9	S	L	22 <sup>5)</sup>	3.0	L	8.0	4	8	0.9	22 <sup>5)</sup>	24	20	○	○	1.5	1.25	0.75	0.75	10
3K	 		709	1	0.9	S	L	22 <sup>5)</sup>	3.0	L	12	4	9	0.7	22 <sup>5)</sup>	26	22 <sup>5)</sup>	○	○	1.7	0.9	1.45	0.65	5
	 		712	1	0.9	S	L	22 <sup>5)</sup>	3.0	L	12	4	12	0.9	22 <sup>5)</sup>	24	20	○	○	1.2	0.85	0.75	0.60	5
	 		718	1	1.3	S	L	20 <sup>5)</sup>	3.4	L/T	7.5	8	18	0.7	22 <sup>5)</sup>	26	22 <sup>5)</sup>	○	○	0.7	0.7	0.4	0.55	5.5
	 		740	2	0.9	S	L	22 <sup>5)</sup>	3.0	L	12	3	10	0.7	22 <sup>5)</sup>	26	22 <sup>5)</sup>	○	○	0.8	0.7	0.5	0.55	5
4K	 		745	2	0.9	S	L	22 <sup>5)</sup>	3.0	L	18	3	16	0.9	22 <sup>5)</sup>	24	20	○	○	1.2	1.45	0.7	1.2	7
5K	 		752	2	2.0	S	A	14	3.9	L	6.5	12	20	1.3	20 <sup>5)</sup>	20	18	-	○	-	-	1.5	1.5	8
	 		759	2	0.9	S	L	22 <sup>5)</sup>	3.0	L	18	3	54	0.9	22 <sup>5)</sup>	24	20	○	○	1.3	1.55	0.9	1.3	3

Note: 1) S = solder, C = crimp

2) A = male for plug; female for socket, L = female for plug; male for socket

3) L = Peek, T = PTFE

4) See calculation method, caution and suggested standard on page 11

5) For a given AWG, the diameter of some stranded conductor designs is larger than the solder cup diameter.

Make sure that the maximum conductor diameter is smaller than øC on page 9 (for solder), and page 10 (for crimp).

● Standard, typically 0-6 weeks delivery for quantities of 250 or less.

○ Non-standard product, contact LEMO USA, typically 6-12 weeks delivery for quantities of 250 or less.

Non-standard product is defined as any product which contains one or more components which are not standard.







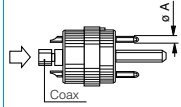
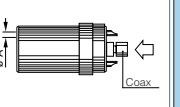
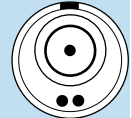
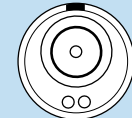

### Mixed (Coax + Low Voltage)

		Reference	Coax								Low voltage										
LV male solder contacts	LV female solder contacts		Number of contacts	Contact ø A (mm)	AWG max.	Contact type <sup>1)</sup>	Impedance (ohms)	Cable Group	Test voltage AC	Test voltage DC	Rated current (A) <sup>1)</sup>	Number of contacts	Contact ø A (mm)	AWG max. (Stranded/Solder)	AWG min. (Stranded/Crimp)	AWG max. (Stranded/Crimp)	Solder	Crimp	Test voltage AC	Test voltage DC	Rated current (A) <sup>4)</sup>
<b>2K</b>		802	1	0.7	26	A1	50	1,2,3	900	1440	5	2	0.9	22 <sup>2)</sup>	24	20	○	○	1000	1500	8
		804	1	0.7	26	A1	50	1,2,3	900	1440	5	4	0.7	22 <sup>2)</sup>	26	22 <sup>2)</sup>	○	○	1200	1800	5
		806	1	0.7	26	A1	50	1,2,3	900	1440	5	6	0.7	22 <sup>2)</sup>	26	22 <sup>2)</sup>	○	○	1200	1800	5
		810	1	0.7	22	C <sup>1)</sup>	50	1,2,3	900	1400	5	6	0.7	22 <sup>2)</sup>	26	22 <sup>2)</sup>	○	○	1700	2500	6.5
<b>3K</b>		803	1	1.3	20 <sup>2)</sup>	A0	50	6	3000	4200	5	3	0.9	22 <sup>2)</sup>	24	20	○	○	800	1200	5
		806	1	0.7	26	A1	50	1,2,3	900	1440	5	6	0.7	22 <sup>2)</sup>	26	22 <sup>2)</sup>	○	○	1200	1800	5
		809	1	0.7	26	A1	50	1,2,3	900	1440	5	9	0.7	22 <sup>2)</sup>	26	22 <sup>2)</sup>	○	○	1200	1800	5
		812	1	0.7	26	A1	50	1,2,3	900	1440	5	12	0.9	22 <sup>2)</sup>	24	20	○	○	1200	1800	5
		813	1	0.7	26	A1	50	1,2,3	900	1440	5	13	0.7	22 <sup>2)</sup>	26	22 <sup>2)</sup>	○	○	1200	1800	5
		822	1	0.7	22 <sup>2)</sup>	C <sup>1)</sup>	50	1,2,3	1500	2190	2	22	0.7	22 <sup>2)</sup>	26	22 <sup>2)</sup>	○	○	1200	1800	5
		844	2	0.7	22 <sup>2)</sup>	C <sup>1)</sup>	50	1,2,3	1500	2190	2	4	0.9	22 <sup>2)</sup>	24	20	○	○	1200	1800	8
		846	2	0.7	22 <sup>2)</sup>	C <sup>1)</sup>	50	1,2,3	1500	2190	2	6	0.9	22 <sup>2)</sup>	24	20	○	○	1200	1800	8
		850	2	0.7	22 <sup>2)</sup>	C <sup>1)</sup>	50	1,2,3	1500	2190	2	10	0.7	22 <sup>2)</sup>	26	22 <sup>2)</sup>	○	○	600	850	5
		856	2	0.7	22 <sup>2)</sup>	C <sup>1)</sup>	50	1,2,3	1500	2190	2	16	0.7	22 <sup>2)</sup>	26	22 <sup>2)</sup>	○	○	600	850	3
		862	3	0.7	22 <sup>2)</sup>	C <sup>1)</sup>	50	1,2,3	1500	2190	2	2	0.9	22 <sup>2)</sup>	24	20	○	○	1200	1800	7
		242	2	0.7	22 <sup>2)</sup>	C <sup>1)</sup>	50	1,2,3	1500	2190	2	-	-	-	-	-	-	-	-	-	-
		243	3	0.7	22 <sup>2)</sup>	C <sup>1)</sup>	50	1,2,3	1500	2190	2	-	-	-	-	-	-	-	-	-	-

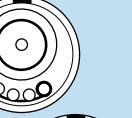
**Note:** 1) You may substitute fluidic/pneumatic or fiber optic contacts  
 2) For a given AWG, the diameter of some stranded conductor designs is larger than the solder cup diameter.  
 Make sure that the maximum conductor diameter is smaller than øC on page 9 (for solder), and page 10 (for crimp).

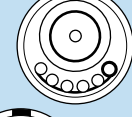
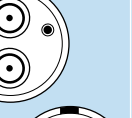
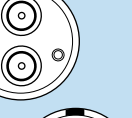
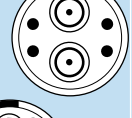
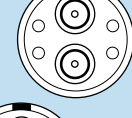
● Standard, typically 0-6 weeks delivery for quantities of 250 or less.  
 ○ Non-standard product, contact LEMO USA, typically 6-12 weeks delivery for quantities of 250 or less.  
 Non-standard product is defined as any product which contains one or more components which are not standard.

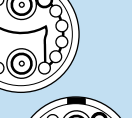
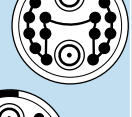
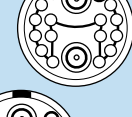
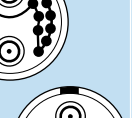
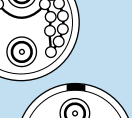
## Mixed (Coax + Low Voltage)

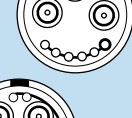
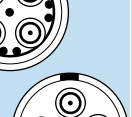
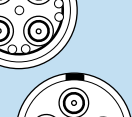
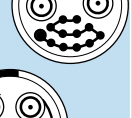
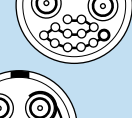
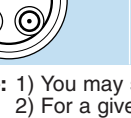
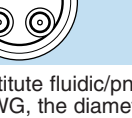
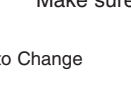
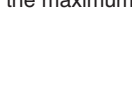
	 LV male solder contacts		 LV female solder contacts		Reference	Coax								Low voltage								
	Number of contacts	Contact $\phi$ A (mm)	AWG max.	Contact type <sup>1)</sup>		Impedance (ohms)	Cable Group	Test voltage AC	Test voltage DC	Rated current (A) <sup>1)</sup>	Number of contacts	Contact $\phi$ A (mm)	AWG max. (Stranded/Solder)	AWG min. (Stranded/Crimp)	AWG max. (Stranded/Crimp)	Solder Crimp	Cont. type	Test voltage AC	Test voltage DC	Rated current (A) <sup>4)</sup>		
4K			802	1	1.6	18	A	50	6	1800	2700	12	2	0.9	22 <sup>2)</sup>	24	20	○	○	1200	1800	8
			822	1	1.3	20	A	75	4,5,7	2400	3300	7	2	0.9	22 <sup>2)</sup>	24	20	○	○	1200	1800	8
			804	1	1.6	18	A	50	6	1800	2700	12	4	0.9	22 <sup>2)</sup>	24	20	○	○	1200	1800	7
			824	1	1.3	20	A	75	4,5,7	2400	3300	7	4	0.9	22 <sup>2)</sup>	24	20	○	○	1200	1800	7
			806	1	1.6	18	A	50	6	1800	2700	12	6	0.9	22 <sup>2)</sup>	24	20	○	○	1200	1800	5
			826	1	1.3	20	A	75	4,5,7	2400	3300	7	6	0.9	22 <sup>2)</sup>	24	20	○	○	1200	1800	5
			842	2	0.7	26	A1	50	1,2,3	900	1440	5	2	0.9	22 <sup>2)</sup>	24	20	○	○	1200	1800	8
			844	2	0.7	26	A1	50	1,2,3	900	1440	5	4	0.9	22 <sup>2)</sup>	24	20	○	○	1200	1800	7
			852	2	0.7	22	C <sup>1</sup>	50	1,2,3	1500	2100	2	12	0.9	22 <sup>2)</sup>	24	20	○	○	1200	1800	4
			856	2	0.7	22	C <sup>1</sup>	50	1,2,3	1500	2100	2	16	0.9	22 <sup>2)</sup>	24	20	○	○	1200	1800	4
			858	2	0.7	22	C <sup>1</sup>	50	1,2,3	1500	2100	2	18	0.7	22 <sup>2)</sup>	26	22 <sup>2)</sup>	○	○	1500	2100	2
			866	3	0.7	22	C <sup>1</sup>	50	1,2,3	1500	2100	2	6	0.7	22 <sup>2)</sup>	26	22 <sup>2)</sup>	○	○	1000	1500	3
			879	4	0.7	22	C <sup>1</sup>	50	1,2,3	1500	2100	2	9	0.7	22 <sup>2)</sup>	26	22 <sup>2)</sup>	○	○	1000	1500	3
			885	3	0.7	22	C <sup>1</sup>	50	1,2,3	1500	2100	2	12	0.7	22 <sup>2)</sup>	26	22 <sup>2)</sup>	○	○	1000	1500	2
			244	4	0.7	22	C <sup>1</sup>	50	1,2,3	1500	2100	2	-	-	-	-	-	-	-	-	-	-

Note: 1) You may substitute fluidic/pneumatic or fiber optic contacts

2) For a given AWG, the diameter of some stranded conductor designs is larger than the solder cup diameter.

Make sure that the maximum conductor diameter is smaller than  $\phi C$  on page 9 (for solder), and page 10 (for crimp).

● Standard, typically 0-6 weeks delivery for quantities of 250 or less.

○ Non-standard product, contact LEMO USA, typically 6-12 weeks delivery for quantities of 250 or less.

Non-standard product is defined as any product which contains one or more components which are not standard.

### Mixed (Coax + Low Voltage)

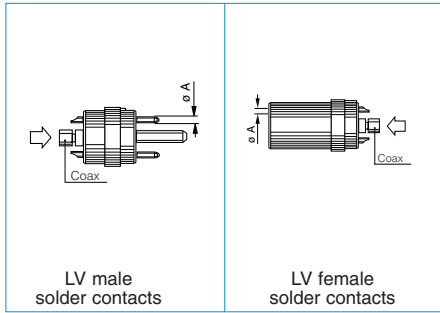

**5K**

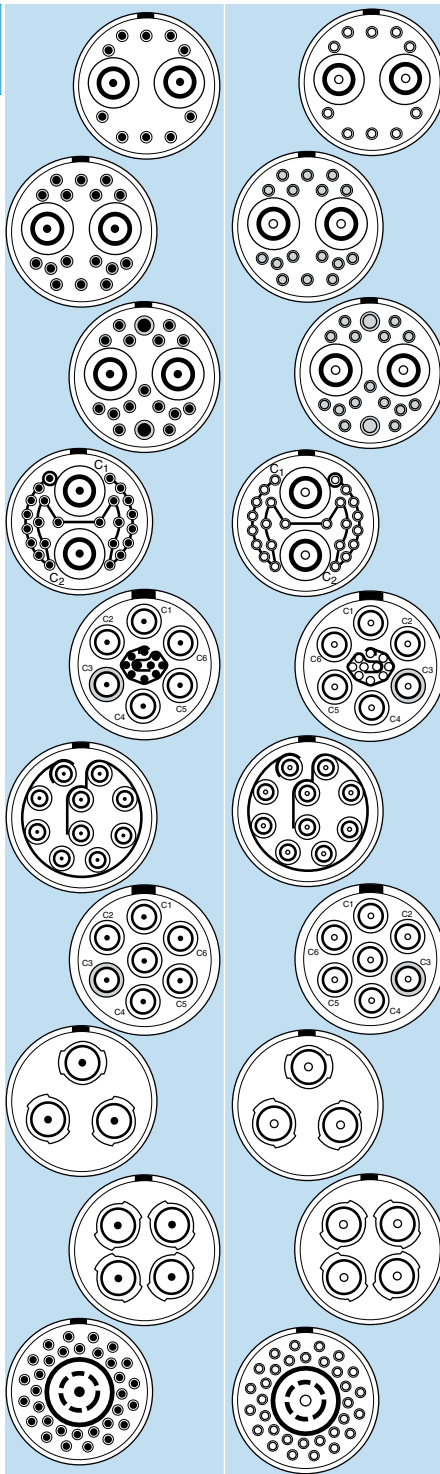

Reference	Coax										Low voltage							
	Number of contacts	Contact ø A (mm)	AWG max.	Contact type <sup>1)</sup>	Impedance (ohms)	Cable Group	Test voltage AC	Test voltage DC	Rated current (A) <sup>1)</sup>	Number of contacts	Contact ø A (mm)	AWG max. (Stranded/Solder)	AWG min. (Stranded/Crimp)	AWG max. (Stranded/Crimp)	Cont. type		Test voltage AC	Test voltage DC
850	2	1.3	20	B	50	1,2,6	840	1380	11	10	0.9	22 <sup>2)</sup>	24	20	○ ○	1500	2100	8
875	2	0.9	22	B	75	3,5	2100	3000	6	10	0.9	22 <sup>2)</sup>	24	20	○ ○	500	2100	8
856	2	1.3	20	B	50	1,2,6	840	1380	11	16	0.9	22 <sup>2)</sup>	24	20	○ ○	1500	2100	8
876	2	0.9	22	B	75	3,5	2100	3000	6	16	0.9	22 <sup>2)</sup>	24	20	○ ○	1500	2100	8
857	2	1.3	20	B	50	1,2,6	840	1380	11	2 15	2.0 0.9	16 22 <sup>2)</sup>	16 24	12 <sup>2)</sup> 20	○ ○ ○ ○	1500	2100	30 8
877	2	0.9	22	B	75	3,5	2100	3000	6	2 15	2.0 0.9	16 22 <sup>2)</sup>	16 24	12 <sup>2)</sup> 20	○ ○ ○ ○	1500	2100	30 8
864	2	1.3	20	B	50	1,2,6	840	1380	11	24	1.3	20 <sup>2)</sup>	20	18	○ ○	1500	2100	8
892	6	0.7	22	D	75	5	1000	1500	5	10	0.9	22 <sup>2)</sup>	24	20	○ ○	600	900	4
240	10	0.7	22	C	50	1,2,3	1000	1500	2	-	-	-	-	-	-	-	-	-
260	7	0.7	22	D	75	5	1000	1500	5	-	-	-	-	-	-	-	-	-
273	3	0.9	22	B	75	3,5	2100	3000	6	-	-	-	-	-	-	-	-	-
274	4	0.9	22	B	75	3,5	2100	3000	6	-	-	-	-	-	-	-	-	-
997	1	0.9	22	A1	50	8	2400	3300	7	32	1.3	20 <sup>2)</sup>	20	18	○ ○	1500	2100	8

**\*Note:** 1) You may substitute fluidic/pneumatic or fiber optic contacts  
2) See footnote 2) page 34

● Standard, typically 0-6 weeks delivery for quantities of 250 or less.  
○ Non-standard product, contact LEMO USA, typically 6-12 weeks delivery for quantities of 250 or less.  
Non-standard product is defined as any product which contains one or more components which are not standard.

## Technical Information

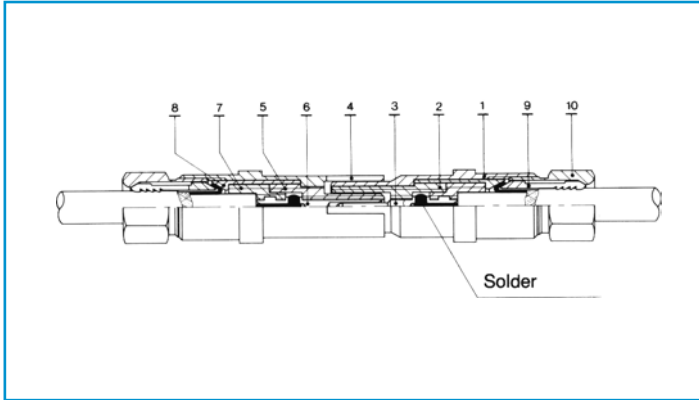

### Coaxial, Type A0, A, A1 and type A3

The coaxial of this type is permanently fixed into the insert. The conductor is soldered and the shield is clamped.

Component	Material	Surface Treatment		
		Cu	Ni	Au
1 Male Sleeve	Brass (UNS C 38500)	0.5	3	1.5
2 Insert	PTFE (UNS D 1457-83)	-	-	-
3 Male Contact	Brass (UNS C 38500)	0.5	3	1.5
4 Female Sleeve	Bronze (UNS C 54400)	0.5	3	2.0
5 Insert	PTFE (UNS D 1457-83)	-	-	-
6 Female Contact	Bronze (UNS C 54400)	0.5	3	2.5
7 Insulating Sleeve	PTFE (UNS D 1457-83)	-	-	-
8 Grounding Sleeve	Brass (UNS C 38500)	0.5	3	-
9 Collet	Brass (UNS C 38500)	0.5	3	-
10 Ferrule	Brass (UNS C 38500)	0.5	3	-

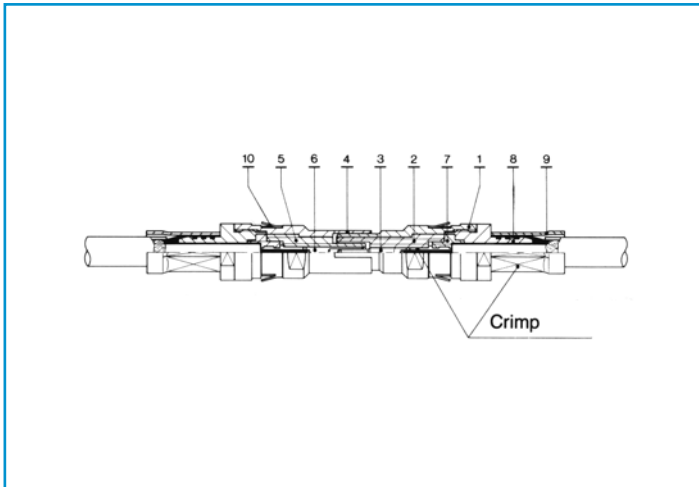

### Coaxial, Type B

In this type, the coaxial is removable and fixed in place by clips. The conductor and shield are crimped.

Component	Material	Surface Treatment		
		Cu	Ni	Au
1 Male Sleeve	Brass (UNS C 38500)	0.5	3	1.5
2 Insert	PTFE (UNS D 1457-83)	-	-	-
3 Male Contact	Brass (UNS C 38500)	0.5	3	1.5
4 Female Sleeve	Bronze (UNS C 54400)	0.5	3	2.0
5 Insert	PTFE (UNS D 1457-83)	-	-	-
6 Female Contact	Bronze (UNS C 54400)	0.5	3	2.5
7 Insulating Sleeve	PTFE (UNS D 1457-83)	-	-	-
8 Crimp Nuts	Brass (UNS C 38500)	0.5	3	1.5
9 Collet	Brass (UNS C 18700)	0.5	3	-
10 Clips	Cu-Be (FS-QQ-C-530)	-	-	-

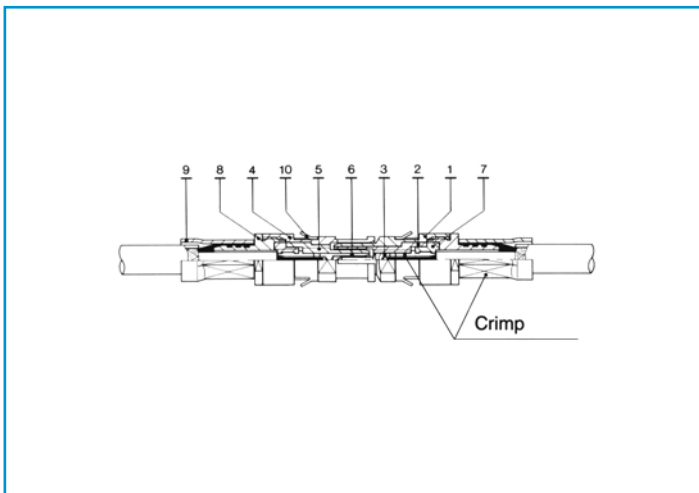

### Coaxial, Type C

In this type, the coaxial is removable and fixed in place by clips. The conductor and shield are crimped.

Component	Material	Surface Treatment		
		Cu	Ni	Au
1 Male Sleeve	Brass (UNS C 38500)	0.5	3	1.5
2 Insert	PTFE (UNS D 1457-83)	-	-	-
3 Male Contact	Brass (UNS C 38500)	0.5	3	1.5
4 Female Sleeve	Bronze (UNS C 54400)	0.5	3	2.0
5 Insert	PTFE (UNS D 1457-83)	-	-	-
6 Female Contact	Bronze (UNS C 54400)	0.5	3	2.5
7 Insulating Sleeve	PTFE (UNS D 1457-83)	-	-	-
8 Crimp Nuts	Brass (UNS C 38500)	0.5	3	1.5
9 Crimp Ferrule	Brass (UNS C 18700)	0.5	3	-
10 Clips	Brass (UNS C 38500)	-	-	-

**Technical characteristics for coax contacts**

**Coaxial, Type D**

In this type, the coaxial is removable and fixed in place by clips. The conductor is soldered and the shield is crimped.

Component	Material	Surface Treatment		
		Cu	Ni	Au
1 Male Sleeve	Brass (UNS C 38500)	0.5	3	1.5
2 Insert	PTFE (UNS D 1457-83)	-	-	-
3 Male Contact	Brass (UNS C 38500)	0.5	3	1.5
4 Female Sleeve	Bronze (UNS C 54400)	0.5	3	2.0
5 Insert	PTFE (UNS D 1457-83)	-	-	-
6 Female Contact	Bronze (UNS C 54400)	0.5	3	2.5
7 Insulating Sleeve	PTFE (UNS D 1457-83)	-	-	-
8 Crimp Nuts	Brass (UNS C 38500)	0.5	3	1.5
9 Crimp Ferrule	Brass (UNS C 18700)	0.5	3	-
10 Clips	Brass (UNS C 38500)	-	-	-

Characteristics	Unit	Coax Type A		Coax Type A1	Coax Type B		Coax Type C	Coax Type D
Impedance	Ω	50	75	50	50	75	50	75
Test voltage at 50 Hz	AC	1800	2300	800	800	2100	1600	1000
Rated current	A	12	7	5	11	6	2	5
Insulating resistance	Ω	>10 <sup>12</sup>	>10 <sup>12</sup>	>10 <sup>12</sup>	>10 <sup>12</sup>	>10 <sup>12</sup>	>10 <sup>12</sup>	>10 <sup>12</sup>
Contact resistance	mΩ	2.0	2.9	3.8	4.1	5.7	5.8	6
Shell to shell resistance	mΩ	1.8	1.8	3	3.2	3.2	3.7	3.2
VSWR (f = GHz)	-	1.01 +0.146f	1.01 +0.019f	1.01 +0.127f	1.06 +0.156f	1.00 +0.22f	1.04 +0.1f	1.00 +0.38f

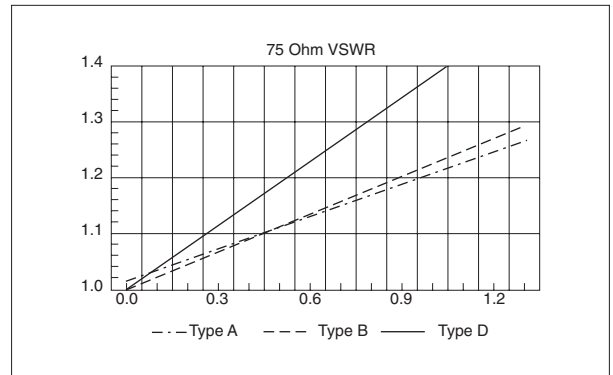
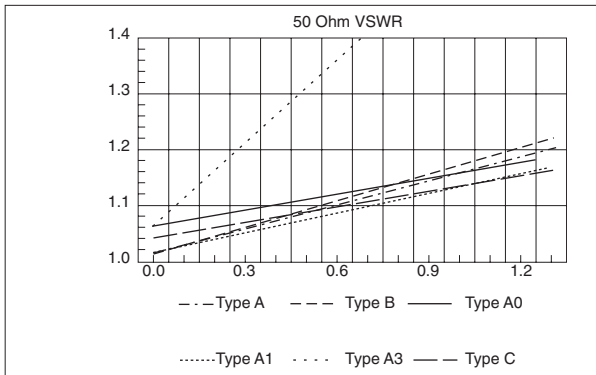

**Recommended coaxial and triaxial cable for mixed coax and multicoax connectors**

Type	Group 1)								
	1	2	3	4	5	6	7	8	9
RG.6 A/U							■		
RG.11 A/U									■
RG.58 C/U						■			
RG.59 B/U					■				
RG.174 A/U	■								
RG.178 B/U		■							
RG.179 B/U			■						
RG.180 B/U				■					
RG.187 A/U			■						
RG.188 A/U	■								
RG.196 A/U		■							
RG.316 /U	■								
Triaxial									■

1) The cable group number corresponding to the chosen cable must be written in the variant position of the part number.

## ● Housings

Ref.	Material	Surface treatment		Note
		Outer shell and collet nut	Latch sleeve and grounding crown	
C	Brass	chrome	nickel	●
N	Brass	nickel	nickel	○
K	Brass	black chrome	nickel	●
S	Stainless steel	without treatment	nickel-plated brass	●
T	Stainless steel	without treatment	stainless steel	○
U	Stainless steel <sup>1)</sup>	without treatment	stainless steel	○
L	Aluminium alloy <sup>2)</sup>	anodized	nickel-plated brass	○
H	PPS <sup>3)</sup> /brass	without treat./Ni	nickel-plated brass	●
G	PEEK <sup>4)</sup>	without treatment	nickel-plated brass	●
P	PA.6 <sup>5)</sup>	without treatment	nickel-plated brass	●
P	PSU <sup>6)</sup>	without treatment	nickel-plated brass	●
R	PPSU <sup>7)</sup>	without treatment	nickel-plated brass	●
X	Avional <sup>8)</sup>	nickel	nickel-plated brass	●

**Note:** detailed characteristics of these materials and treatments are presented on page 5.

<sup>1)</sup> The other metallic parts are in stainless steel.

<sup>2)</sup> The «variant» position of the reference is used to specify the anodized color. See color chart on page 81.

<sup>3)</sup> Only available for elbow (90°) receptacles for printed circuit of the B and S series.

<sup>4)</sup> Only available for FGG and ENG models of the B series.

<sup>5)</sup> Only for CFF and CRG bridge plugs.

<sup>6)</sup> Only available for ENY and FGY models of the B series. For the color, see the «variant» position.

<sup>7)</sup> Only available for ENY and FGY models of the B series.

<sup>8)</sup> Anthracite color.

● First choice alternative ○ Special order alternative

## ● Insulators

Ref.	Material	Note
L	PEEK	1)
Y	PEEK	2)

**Note:** Detailed characteristics of these materials are presented on page 7.

<sup>1)</sup> For solder or printed circuit contacts.

<sup>2)</sup> Only for crimp contacts. For the type 3B.309; 4B.304; 4B.307; 4B.320; 5B.304 and 5B.350, the reference shall be «L» instead of «Y».

## ● Contacts

### Contacts for plugs, free or fixed receptacles

Ref.	Contact type	Ref.	Contact type
A	Male solder	M	Female crimp (fig. 1) <sup>1)</sup>
C	Male crimp (fig. 1) <sup>1)</sup>	P	Female crimp (fig. 2) <sup>1)</sup>
B	Male crimp (fig. 2) <sup>1)</sup>	U	Female crimp (fig. 2) <sup>1)</sup>
G	Male crimp (fig. 2) <sup>1)</sup>	N	Female straight printed circuit
L	Female solder	V	Female elbow printed circuit

**Note:** <sup>1)</sup> There are two forms of crimp barrels. Please consult adjacent table, and page 10 for contact selection .

### Contacts for couplers, plug with receptacle and bridge plug

Ref.	Contact type	Ref.	Contact type
A	Male - Female	F	Female - Female - Male
C	Male - Male	L	Female - Male
E	Male - Male - Female		

**Note:** The first contact type mentioned is always the one at the flange end.

### Dimension of crimp barrels

Contact			Ref. contact type		Conductor			
ø A (mm)	ø C (mm)	Form per fig.	Male	Female	AWG		Section (mm <sup>2</sup> )	
					min.	max.	min.	max.
0.5	0.45	1	C	M	32	28	0.035	0.09
	0.80	1	C	M	26	22	0.140	0.34
0.7	0.45	2	B	P	32	28	0.035	0.09
	1.10	1	C	M	24	20	0.250	0.50
0.9	0.80	2	B	P	26	22	0.140	0.34
	0.45	2	G	U	32	28	0.035	0.09
1.3	1.40	1	C	M	20	18	0.500	1.00
	1.10	2	B	P	24	20	0.250	0.50
1.6	0.80	2	G	U	26	22	0.140	0.34
	1.90	1	C	M	18	14	1.000	1.50
2.0	1.40	2	B	P	22	18	0.340	1.00
	2.40	1	C	M	16	12	1.500	2.50
3.0	1.90	2	B	P	18	14	1.000	1.50
	2.90	1	C	M	14	10	2.500	4.00
4.0	4.00	1	C	M	12	10	4.000	6.00



# ● Collets

## C and K type collets



	Reference		Collet $\phi$		Cable $\phi$		Part number of the collet system <sup>1)</sup>	Part number of the oversize collet and of the two split center-pieces <sup>2)</sup>	Part number of the collet nut <sup>2)</sup>	Availability
	Type	$\phi$	$\phi$ A	$\phi$ B	max.	min.				
<b>OK</b>	C	10	1.6	–	1.2	1.0	FFA.0E.710.CNS	–	FFA.0E.130.LC	○
	C	15	1.6	–	1.5	1.3	FFA.0E.715.CNS	–	FFA.0E.130.LC	○
	C	20	2.1	–	2.0	1.6	FFA.0E.720.CNS	–	FFA.0E.130.LC	○
	C	25	3.1	–	2.5	2.1	FFA.0E.725.CNS	–	FFA.0E.130.LC	○
	C	30	3.1	–	3.0	2.6	FFA.0E.730.CNS	–	FFA.0E.130.LC	●
	C	35	4.2	4.2	3.5	3.1	FFA.0E.735.CNS	–	FFA.0E.130.LC	●
	C	40	4.2	4.2	4.0	3.6	FFA.0E.740.CNS	–	FFA.0E.130.LC	○
	C	45	5.2	5.2	4.5	4.1	FFA.0E.745.CNS	–	FFA.0E.131.LC	●
	C	50	5.2	5.2	5.0	4.6	FFA.0E.750.CNS	–	FFA.0E.131.LC	●
<b>1K</b>	C	15	1.6	–	1.5	1.3	FFA.1E.715.CNS	–	FFA.1E.130.LC	○
	C	20	2.2	–	2.0	1.6	FFA.1E.720.CNS	–	FFA.1E.130.LC	○
	C	25	3.2	–	2.5	2.1	FFA.1E.725.CNS	–	FFA.1E.130.LC	●
	C	30	3.2	–	3.0	2.6	FFA.1E.730.CNS	–	FFA.1E.130.LC	●
	C	35	4.2	–	3.5	3.1	FFA.1E.735.CNS	–	FFA.1E.130.LC	○
	C	40	4.2	–	4.0	3.6	FFA.1E.740.CNS	–	FFA.1E.130.LC	●
	C	45	5.2	–	4.5	4.1	FFA.1E.745.CNS	–	FFA.1E.130.LC	●
	C	50	5.2	–	5.0	4.6	FFA.1E.750.CNS	–	FFA.1E.130.LC	●
	C	55	6.2	6.2	5.5	5.1	FFA.1E.755.CNS	–	FFA.1E.130.LC	●
	C	60	6.2	6.2	6.0	5.6	FFA.1E.760.CNS	–	FFA.1E.130.LC	●
	C	65	7.2	6.7	6.5	6.1	FFA.1E.765.CNS	–	FFA.1E.130.LC	●
	K	70	7.2	–	7.0	6.6	FFA.2E.770.CNS	FFA.1K.137.LCN	FFA.2E.130.LC <sup>2)</sup>	○
	K	75	8.2	8.2	7.5	7.1	FFA.2E.775.CNS	FFA.1K.137.LCN	FFA.2E.130.LC <sup>2)</sup>	○
K	80	8.2	8.2	8.0	7.6	FFA.2E.780.CNS	FFA.1K.137.LCN	FFA.2E.130.LC <sup>2)</sup>	○	
K	85	9.2	8.6	8.5	8.1	FFA.2E.785.CNS	FFA.1K.137.LCN	FFA.2E.130.LC <sup>2)</sup>	○	
<b>2K</b>	C	15	2.2	–	1.5	1.3	FFA.2E.715.CNS	–	FFA.2E.130.LC	○
	C	20	2.2	–	2.0	1.6	FFA.2E.720.CNS	–	FFA.2E.130.LC	○
	C	25	3.2	–	2.5	2.1	FFA.2E.725.CNS	–	FFA.2E.130.LC	○
	C	30	3.2	–	3.0	2.6	FFA.2E.730.CNS	–	FFA.2E.130.LC	○
	C	35	4.2	–	3.5	3.1	FFA.2E.735.CNS	–	FFA.2E.130.LC	○
	C	40	4.2	–	4.0	3.6	FFA.2E.740.CNS	–	FFA.2E.130.LC	○
	C	45	5.2	–	4.5	4.1	FFA.2E.745.CNS	–	FFA.2E.130.LC	○
	C	50	5.2	–	5.0	4.6	FFA.2E.750.CNS	–	FFA.2E.130.LC	○
	C	55	6.2	–	5.5	5.1	FFA.2E.755.CNS	–	FFA.2E.130.LC	●
	C	60	6.2	–	6.0	5.6	FFA.2E.760.CNS	–	FFA.2E.130.LC	●
	C	65	7.2	–	6.5	6.1	FFA.2E.765.CNS	–	FFA.2E.130.LC	●
	C	70	7.2	–	7.0	6.6	FFA.2E.770.CNS	–	FFA.2E.130.LC	●
	C	75	8.2	8.2	7.5	7.1	FFA.2E.775.CNS	–	FFA.2E.130.LC	●
	C	80	8.2	8.2	8.0	7.6	FFA.2E.780.CNS	–	FFA.2E.130.LC	○
	C	85	9.2	8.6	8.5	8.1	FFA.2E.785.CNS	–	FFA.2E.130.LC	○
	K	90	9.2	–	9.0	8.6	FFA.3E.790.CNS	FFA.2K.137.LCN	FFA.3E.130.LC <sup>2)</sup>	○
	K	95	10.2	10.2	9.5	9.1	FFA.3E.795.CNS	FFA.2K.137.LCN	FFA.3E.130.LC <sup>2)</sup>	○
	K	10	10.2	10.2	10.0	9.6	FFA.3E.710.CNS	FFA.2K.137.LCN	FFA.3E.130.LC <sup>2)</sup>	○
	K	11	11.2	10.6	10.5	10.1	FFA.3E.711.CNS	FFA.2K.137.LCN	FFA.3E.130.LC <sup>2)</sup>	○

**Note:**

<sup>1)</sup> For ordering the collet system separately.

<sup>2)</sup> For ordering the K type collet, the oversize collet and the split center-pieces, as well as the corresponding collet nut should be ordered.

All dimensions are in millimeters.

● Standard, typically 0-6 weeks delivery for quantities of 250 or less.  
 ○ Non-standard product, contact LEMO USA, typically 6-12 weeks delivery for quantities of 250 or less.  
 Non-standard product is defined as any product which contains one or more components which are not standard.

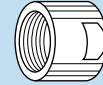
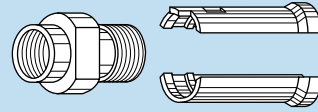
**C and K type collets**

**3K**
**4K**

Reference		Collet ø		Cable ø		Part number of the collet system <sup>1)</sup>	Part number of the oversize collet and of the two split center-pieces <sup>2)</sup>	Part number of the collet nut <sup>2)</sup>	Availability
Type	ø	ø A	ø B	max.	min.				
C	30	3.2	–	3.0	2.6	FFA.3E.730.CNS	–	FFA.3E.130.LC	○
C	35	4.2	–	3.5	3.1	FFA.3E.735.CNS	–	FFA.3E.130.LC	○
C	40	4.2	–	4.0	3.6	FFA.3E.740.CNS	–	FFA.3E.130.LC	○
C	45	5.2	–	4.5	4.1	FFA.3E.745.CNS	–	FFA.3E.130.LC	○
C	50	5.2	–	5.0	4.6	FFA.3E.750.CNS	–	FFA.3E.130.LC	○
C	55	6.2	–	5.5	5.1	FFA.3E.755.CNS	–	FFA.3E.130.LC	○
C	60	6.2	–	6.0	5.6	FFA.3E.760.CNS	–	FFA.3E.130.LC	○
C	65	7.2	–	6.5	6.1	FFA.3E.765.CNS	–	FFA.3E.130.LC	○
C	70	7.2	–	7.0	6.6	FFA.3E.770.CNS	–	FFA.3E.130.LC	○
C	75	8.2	–	7.5	7.1	FFA.3E.775.CNS	–	FFA.3E.130.LC	○
C	80	8.2	–	8.0	7.6	FFA.3E.780.CNS	–	FFA.3E.130.LC	○
C	85	9.2	–	8.5	8.1	FFA.3E.785.CNS	–	FFA.3E.130.LC	○
C	90	9.2	–	9.0	8.6	FFA.3E.790.CNS	–	FFA.3E.130.LC	●
C	95	10.2	10.2	9.5	9.1	FFA.3E.795.CNS	–	FFA.3E.130.LC	○
C	10	10.2	10.2	10.0	9.6	FFA.3E.710.CNS	–	FFA.3E.130.LC	○
C	11	11.2	10.6	10.5	10.1	FFA.3E.711.CNS	–	FFA.3E.130.LC	○
K	11	12.3	–	12.0	10.6	FFA.4E.711.CNS	FFA.3K.137.LCN	FFA.4E.130.LC <sup>2)</sup>	○
K	12	13.8	13.8	12.8	12.1	FFA.4E.712.CNS	FFA.3K.137.LCN	FFA.4E.130.LC <sup>2)</sup>	○
K	13	13.8	13.8	13.5	12.9	FFA.4E.713.CNS	FFA.3K.137.LCN	FFA.4E.130.LC <sup>2)</sup>	○
K	14	15.3	15.3	14.0	13.6	FFA.4E.714.CNS	FFA.3K.137.LCN	FFA.4E.130.LC <sup>2)</sup>	○
K	15	15.3	15.3	15.0	14.1	FFA.4E.715.CNS	FFA.3K.137.LCN	FFA.4E.130.LC <sup>2)</sup>	○
C	50	6.3	–	5.0	4.8	FFA.4E.750.CNS	–	FFA.4E.130.LC	○
C	55	6.3	–	5.5	5.1	FFA.4E.755.CNS	–	FFA.4E.130.LC	○
C	60	6.3	–	6.0	5.6	FFA.4E.760.CNS	–	FFA.4E.130.LC	○
C	65	7.3	–	6.5	6.1	FFA.4E.765.CNS	–	FFA.4E.130.LC	○
C	70	7.3	–	7.0	6.6	FFA.4E.770.CNS	–	FFA.4E.130.LC	○
C	75	8.3	–	7.5	7.1	FFA.4E.775.CNS	–	FFA.4E.130.LC	○
C	80	8.3	–	8.0	7.6	FFA.4E.780.CNS	–	FFA.4E.130.LC	○
C	85	9.3	–	8.5	8.1	FFA.4E.785.CNS	–	FFA.4E.130.LC	○
C	90	9.3	–	9.0	8.6	FFA.4E.790.CNS	–	FFA.4E.130.LC	○
C	95	10.8	–	9.5	9.1	FFA.4E.795.CNS	–	FFA.4E.130.LC	○
C	10	10.8	–	10.5	9.6	FFA.4E.710.CNS	–	FFA.4E.130.LC	○
C	11	12.3	–	12.0	10.6	FFA.4E.711.CNS	–	FFA.4E.130.LC	○
C	12	13.8	13.8	12.8	12.1	FFA.4E.712.CNS	–	FFA.4E.130.LC	○
C	13	13.8	13.8	13.5	12.9	FFA.4E.713.CNS	–	FFA.4E.130.LC	○
C	14	15.3	15.3	14.0	13.6	FFA.4E.714.CNS	–	FFA.4E.130.LC	○
C	15	15.3	15.3	15.0	14.1	FFA.4E.715.CNS	–	FFA.4E.130.LC	○
K	16	17.8	–	16.5	15.6	FFA.4K.716.CNS	FFA.4K.137.LCN <sup>3)</sup>	FFA.4K.136.LC <sup>2)</sup>	○
K	17	17.8	–	17.5	16.6	FFA.4K.717.CNS	FFA.4K.137.LCN <sup>3)</sup>	FFA.4K.136.LC <sup>2)</sup>	○
K	18	19.8	–	18.5	17.6	FFA.4K.718.CNS	FFA.4K.137.LCN <sup>3)</sup>	FFA.4K.136.LC <sup>2)</sup>	○
K	19	19.8	–	19.5	18.6	FFA.4K.719.CNS	FFA.4K.137.LCN <sup>3)</sup>	FFA.4K.136.LC <sup>2)</sup>	○
K	20	21.8	–	20.5	19.6	FFA.4K.720.CNS	FFA.4K.137.LCN <sup>3)</sup>	FFA.4K.136.LC <sup>2)</sup>	○
K	21	21.8	–	21.5	20.6	FFA.4K.721.CNS	FFA.4K.137.LCN <sup>3)</sup>	FFA.4K.136.LC <sup>2)</sup>	○
K	22	23.8	23.8	22.5	21.6	FFA.4K.722.CNS	FFA.4K.137.LCN <sup>3)</sup>	FFA.4K.136.LC <sup>2)</sup>	○
K	23	23.8	23.8	23.5	22.6	FFA.4K.723.CNS	FFA.4K.137.LCN <sup>3)</sup>	FFA.4K.136.LC <sup>2)</sup>	○

**Note:**
<sup>1)</sup> For ordering the collet system separately.

<sup>2)</sup> For ordering the K type collet, the oversize collet and the split center-pieces, as well as the corresponding collet nut should be ordered.

<sup>3)</sup> In 4K series, the center-piece is made of one piece.

All dimensions are in millimeters.

● Standard, typically 0-6 weeks delivery for quantities of 250 or less.

○ Non-standard product, contact LEMO USA, typically 6-12 weeks delivery for quantities of 250 or less.

Non-standard product is defined as any product which contains one or more components which are not standard.

### C type collets

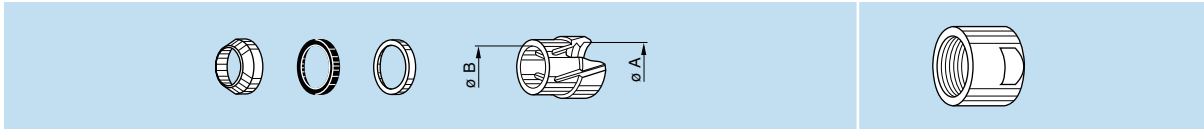

	Reference		Collet $\varnothing$		Cable $\varnothing$		Part number of the collet system <sup>1)</sup>	Part number of the collet nut	Availability
	Type	$\varnothing$	$\varnothing A$	$\varnothing B$	max.	min.			
<b>5K</b>	C	10	11.8	–	10.5	9.6	FFA.5K.710.CNS	FFA.5K.130.LC	○
	C	11	11.8	–	11.5	10.6	FFA.5K.711.CNS	FFA.5K.130.LC	○
	C	12	13.8	–	12.5	11.6	FFA.5K.712.CNS	FFA.5K.130.LC	○
	C	13	13.8	–	13.5	12.6	FFA.5K.713.CNS	FFA.5K.130.LC	○
	C	14	15.8	–	14.5	13.6	FFA.5K.714.CNS	FFA.5K.130.LC	○
	C	15	15.8	–	15.5	14.6	FFA.5K.715.CNS	FFA.5K.130.LC	○
	C	16	17.8	–	16.5	15.6	FFA.5K.716.CNS	FFA.5K.130.LC	○
	C	17	17.8	–	17.5	16.6	FFA.5K.717.CNS	FFA.5K.130.LC	○
	C	18	19.8	–	18.5	17.6	FFA.5K.718.CNS	FFA.5K.130.LC	○
	C	19	19.8	–	19.5	18.6	FFA.5K.719.CNS	FFA.5K.130.LC	○
	C	20	21.8	–	20.5	19.6	FFA.5K.720.CNS	FFA.5K.130.LC	○
	C	21	21.8	–	21.5	20.6	FFA.5K.721.CNS	FFA.5K.130.LC	○
	C	22	23.8	23.8	22.5	21.6	FFA.5K.722.CNS	FFA.5K.130.LC	○
C	23	23.8	23.8	23.5	22.6	FFA.5K.723.CNS	FFA.5K.130.LC	○	

**Note:**

<sup>1)</sup> For ordering the collet system separately.

### Bend relief collet nut and bend relief

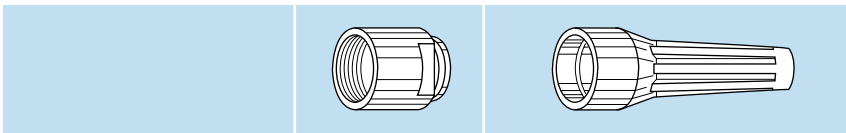

	Reference		Part number of the collet nut	Bend relief to be used <sup>1)</sup>
	Type	$\varnothing$		
<b>0K</b>	C	10 to 50	FFM.0E.130.LC	GMA.0B.●●●.●●
<b>1K</b>	C	15 to 65	FFM.1E.130.LC	GMA.1B.●●●.●●
	K	70 to 85	FFM.2E.130.LC	GMA.2B.●●●.●●
<b>2K</b>	C	15 to 85	FFM.2E.130.LC	GMA.2B.●●●.●●
	K	90 to 10	FFM.3E.130.LC	GMA.3B.●●●.●●
<b>3K</b>	C	30 to 10	FFM.3E.130.LC	GMA.3B.●●●.●●
	K	11 to 15	FFM.4E.130.LC	GMA.4B.●●●.●●
<b>4K</b>	C	50 to 15	FFM.4E.130.LC	GMA.4B.●●●.●●

**Note:** <sup>1)</sup> The bend relief is to be ordered separately (see pages 91 and 92).

All dimensions are in millimeters.



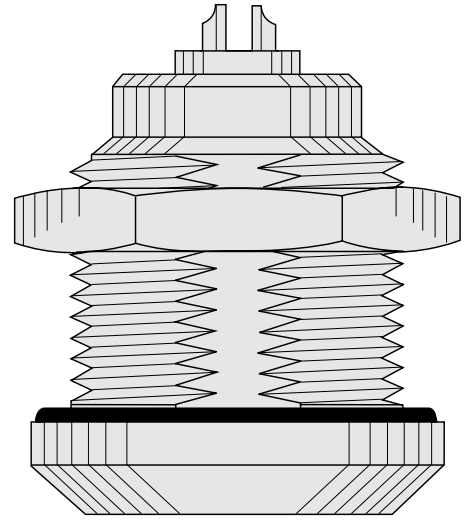

- **E Series Connectors**

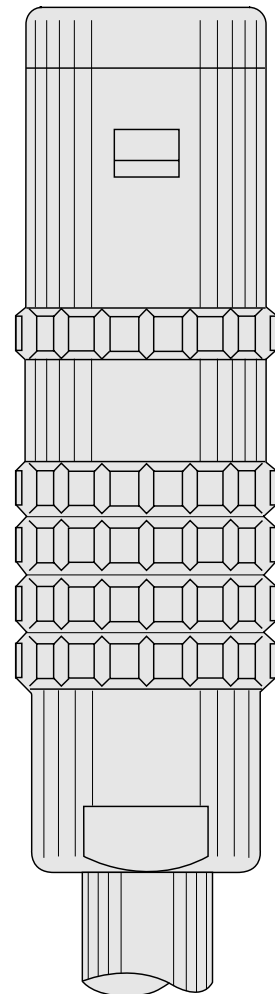

## ● E Series Connectors

E series connectors have been specifically designed for outdoor applications. They include an inner sleeve and two seals to prevent penetration of solids or liquids into the housing formed by the plug, free receptacle, fixed receptacle or coupler. All models of these series are watertight when mated and give a protection index of IP 68 as per IEC 60529 standard (in mated condition) when correctly assembled to an appropriate cable (IP 66 otherwise).

- security of the Push-Pull latching system
- watertight connection (IP 68/IP 66)
- single contact types transmitting current up to 230 A and multicontact types with up to 106 contacts
- hybrid types (multicontact, high voltage, low voltage, coaxial)
- solder or printed circuit contacts (straight or elbow)
- polarization by stepped insert (half-moon) fitted with male and female contacts
- wide range of models satisfying most applications
- 360° screening for full EMC shielding
- rugged housing for extreme working conditions.

### Interconnections

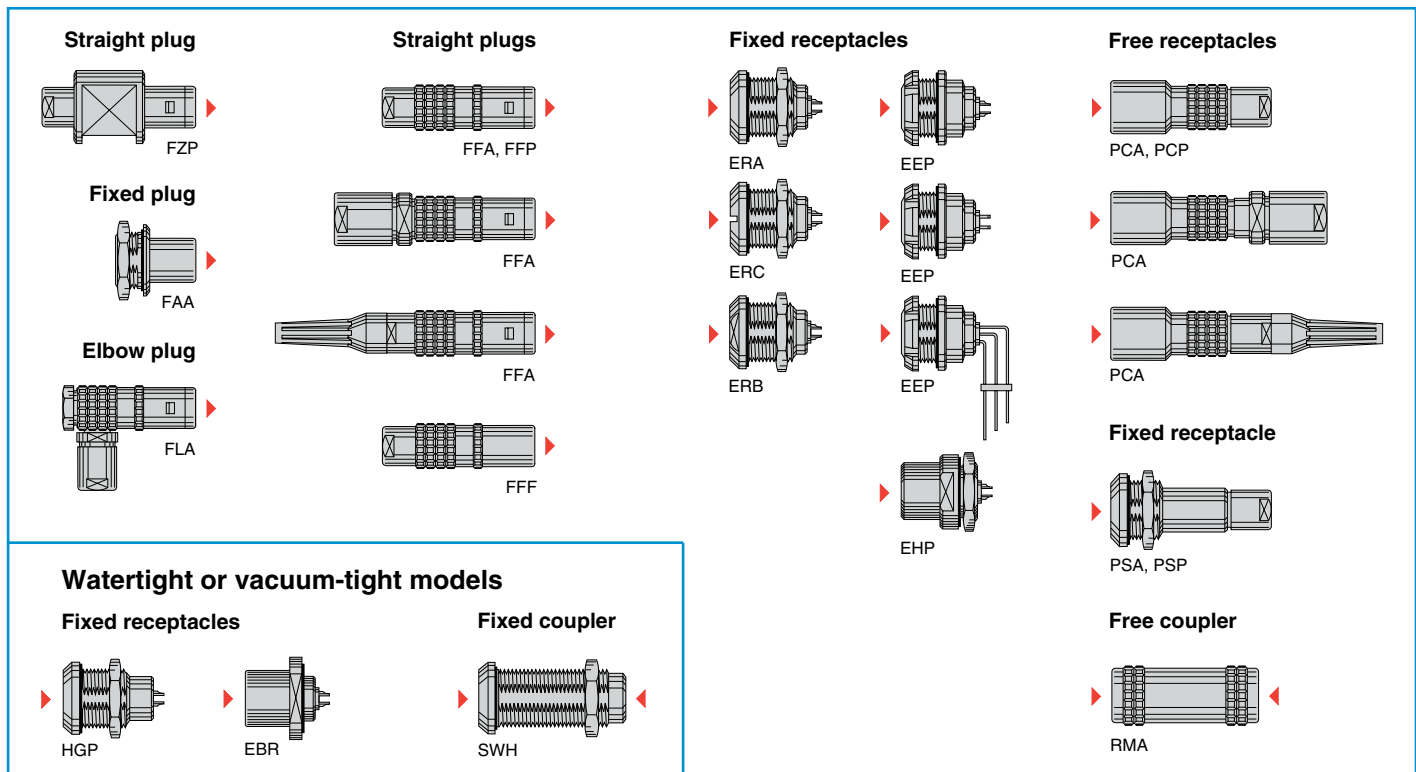

### Model Description

- |   |  |  |
|---|--|--|
| <p><b>EBR</b> Fixed receptacle with round flange, watertight, protruding shell and screw fixing</p> <p><b>EEP</b> Fixed receptacle, nut fixing (back panel mounting)</p> <p><b>EEP</b> Fixed receptacle, nut fixing, with elbow (90°) contacts for printed circuit (back panel mounting)</p> <p><b>EEP</b> Fixed receptacle, nut fixing, with straight contacts for printed circuit (back panel mounting)</p> <p><b>EHP</b> Fixed receptacle, nut fixing, protruding shell</p> <p><b>ERA</b> Fixed receptacle, nut fixing</p> <p><b>ERB</b> Fixed receptacle, nut fixing with two flats in the flange</p> | <p><b>ERC</b> Fixed receptacle, nut fixing with slot in the flange</p> <p><b>FAA</b> Fixed plug non-latching, nut fixing</p> <p><b>FFA</b> Straight plug, cable collet</p> <p><b>FFA</b> Straight plug with oversize cable collet</p> <p><b>FFA</b> Straight plug, cable collet and nut for fitting a bend relief</p> <p><b>FFF</b> Straight plug non-latching, cable collet</p> <p><b>FFP</b> Straight plug, cable collet and inner anti-rotating device</p> <p><b>FLA</b> Elbow (90°) plug, cable collet</p> <p><b>FZP</b> Straight plug for remote handling, cable collet and inner anti-rotating device</p> <p><b>HGP</b> Fixed receptacle, nut fixing, watertight or vacuum-tight</p> <p><b>PCA</b> Free receptacle, cable collet</p> | <p><b>PCA</b> Free receptacle with oversize cable collet</p> <p><b>PCA</b> Free receptacle, cable collet and nut for fitting a bend relief</p> <p><b>PCP</b> Free receptacle, cable collet and inner anti-rotating device</p> <p><b>PSA</b> Fixed receptacle, nut fixing, cable collet</p> <p><b>PSP</b> Fixed receptacle, nut fixing, cable and inner anti-rotating device</p> <p><b>RMA</b> Free coupler</p> <p><b>SWH</b> Fixed coupler, nut fixing, watertight or vacuum-tight</p> |
|---|--|--|

## Part Section Showing Internal Components

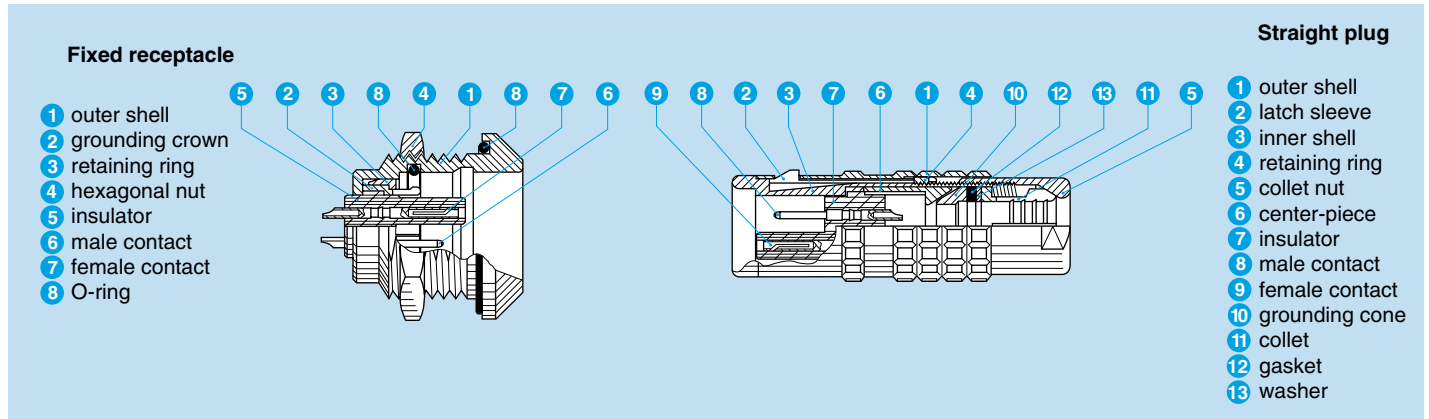

## Technical Characteristics

### Mechanical and Climatic

Characteristics	Value	Standard
Endurance	> 5000 cycles	IEC 60512-5 test 9a
Humidity	up to 95% at 140° F	
Temperature range <sup>1) 2)</sup>	-58° F, +392° F	
Resistance to vibrations	10-2000 Hz, 15 g	IEC 60512-4 test 6d
Shock resistance	100 g, 6 ms	IEC 60512-4 test 6c
Salt spray corrosion test	> 144h	IEC 60512-6 test 11f
Protection index (mated)	IP 68/IP 66	IEC 60529
Climatic category <sup>1)</sup>	50/175/21	IEC 60068-1

### Electrical

Characteristics	Value	Standard	
Shielding efficiency	at 10 MHz	> 95 dB	IEC 60169-1-3
	at 1 GHz	> 80 dB	IEC 60169-1-3

**Note:** The various tests have been carried out with FFA and ERA connector pairs, with chrome-plated brass shell, PEEK insulator and silicone O-ring. Detailed electrical characteristics, as well as materials and treatment are presented in the chapter Technical Characteristics on page 5.

<sup>1)</sup> For watertight or vacuum-tight models see page 53.

<sup>2)</sup> Minimum operating temperature is -4° F for receptacles fitted with an FPM (Viton) O-ring.

## Available Models (series and types)

Model	Single contact					Multicontact							
	0E	1E	2E	3E	4E	5E	0E	1E	2E	3E	4E	5E	6E
EBR			●						●				
EEP	●	●	●	●			●	●	●	●			
EEP <sup>1)</sup>									●				
EGG <sup>5)</sup>													●
EHP	●	●	●				●	●	●				
ERA	●	●	●	●	●	●	●	●	●	●	●	●	
ERB	●	●	●	●			●	●	●	●			
ERC	●			●	●		●			●	●		
FAA	●	●	●	●			●	●	●	●			
FFA	●	●	●	●	●	●	●	●	●	●	●	●	
FFA <sup>2)</sup>		●	●	●	●			●	●	●	●		
FFA <sup>3)</sup>	●	●	●	●	●		●	●	●	●	●		
FFF	●	●					●	●					
FFP				●	●					●	●		

Model	Single contact					Multicontact							
	0E	1E	2E	3E	4E	5E	0E	1E	2E	3E	4E	5E	6E
FGG <sup>5)</sup>													●
FLA							●	●	●	●	●		
FZP		●	●	●	●	●		●	●	●	●	●	
HGP <sup>4)</sup>	●	●		●	●	●	●	●	●	●	●	●	●
PCA	●	●	●	●	●	●	●	●	●	●	●	●	
PCA <sup>2)</sup>		●	●	●	●			●	●	●	●		
PCA <sup>3)</sup>	●	●	●	●	●		●	●	●	●	●		
PCP				●	●					●	●		
PHG <sup>5)</sup>													●
PKG <sup>5)</sup>													●
PSA	●	●	●	●	●	●	●	●	●	●	●	●	
PSP				●	●	●				●	●	●	
RMA	●	●	●	●	●	●	●	●	●	●	●	●	
SWH <sup>4)</sup>	●	●	●	●	●	●	●	●	●	●	●	●	●

**Note:**

RMA and SWH models are not available in all types. Please consult pages corresponding to the models.

<sup>1)</sup> with elbow (90°) printed circuit contacts

<sup>2)</sup> with oversize cable collet

<sup>3)</sup> with cable collet and nut for fitting a bend relief

<sup>4)</sup> with key (6E series)

<sup>5)</sup> with key (G)

● = available models by series and types

## ● Part Number Example

### Straight plug with cable collet

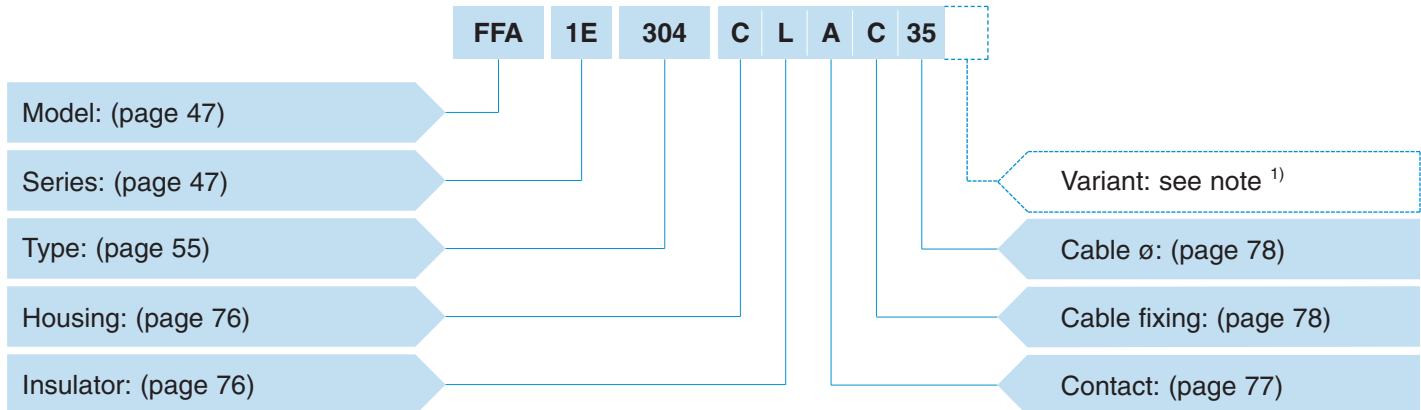

**FFA.1E.304.CLAC35** = straight plug with cable collet, 1E series, multicontact type with four contacts, chrome-plated brass shell and PEEK insulator, male solder contacts, C type collet for a 3.5 mm diameter cable.

### Fixed receptacle

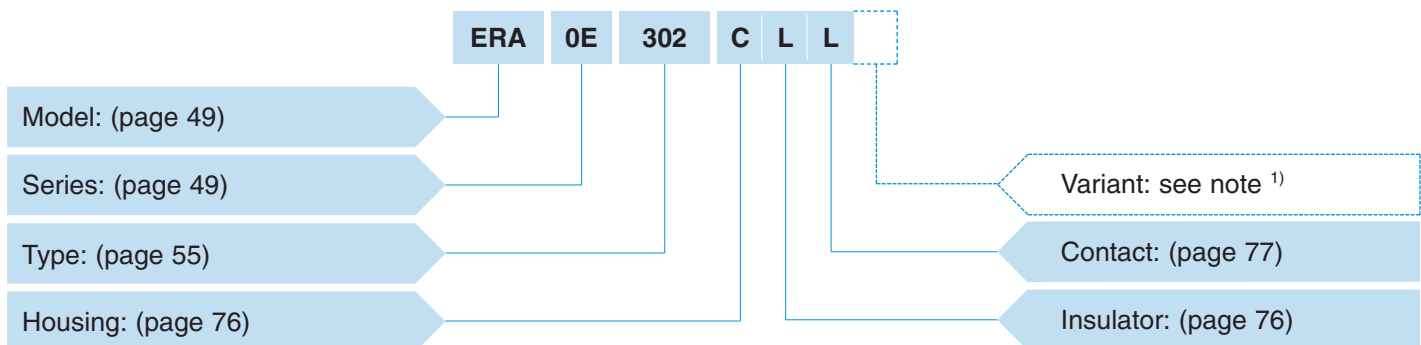

**ERA.0E.302.CLL** = fixed receptacle, nut fixing, 0E series, multicontact type with two contacts, chrome-plated outer shell, PEEK insulator, female solder contacts.

### Straight coupler

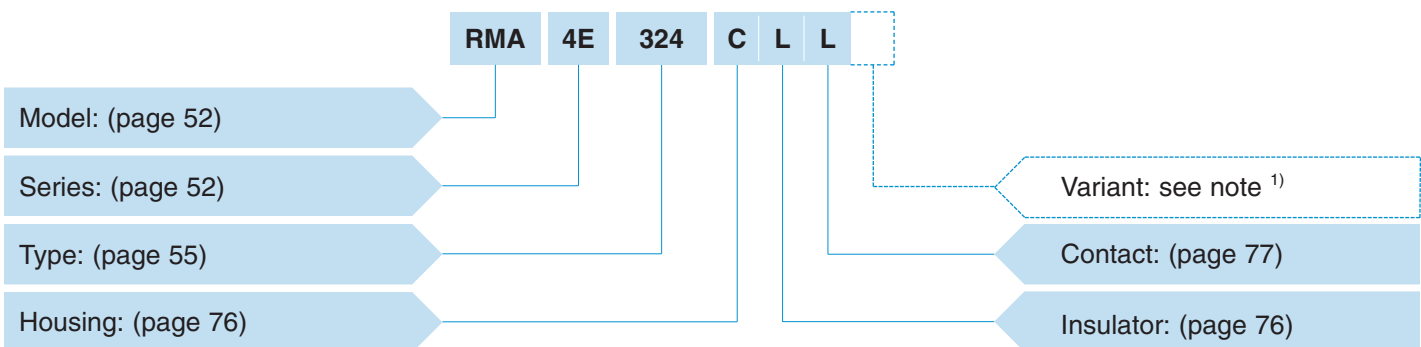

**RMA.4E.324.CLL** = straight coupler, 4E series, multicontact type with 24 contacts, chrome-plated brass outer shell PEEK insulator, 12 female and 12 male contacts each end.

**Note:** <sup>1)</sup> The «Variant» position of the part number is used to specify either the presence of a nut for fitting a bend relief, or the anodized color of the aluminium housings.  
 For models with collet nut for fitting a bend relief, a «Z» should be indicated and a bend relief can be ordered separately as indicated in the «Accessories» section. An order for a connector with bend relief should thus include two part numbers.  
 For the various housings available in colors, the corresponding letter in the part number for the color is indicated on page 81.  
 For the watertight models of receptacle, the letter «P» is used; for the vacuum-tight models of receptacle the letters «PV» shall be indicated.  
 For the plug and receptacle that should be fitted with an FPM (Viton) O-ring the letter «H» shall be indicated.



## ● Models

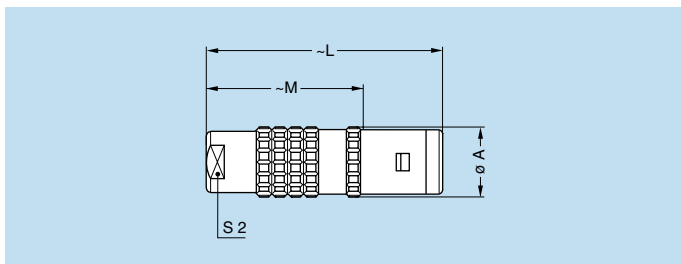
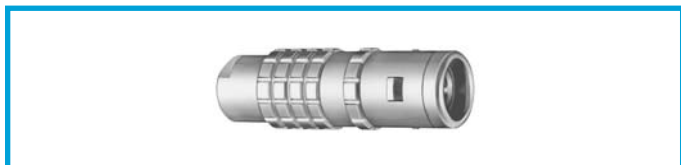

### FFA Straight plug, cable collet

Reference		Dimensions (mm)				Availability
Model	Series	A	L	M	S2	
FFA	0E	11	34	23.0	8	●
FFA	1E	13	42	28.0	9	●
FFA	2E	16	52	36.0	12	●
FFA	3E	19	61	41.0	15	●
FFA	4E	25	71	50.5	19	○
FFA	5E	38	92	67.0	32	○
FGG <sup>1)</sup>	6E	47	118	89.0	38	○

**Note:** 1) With key (G)

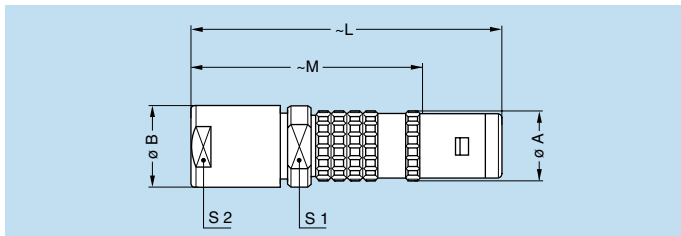
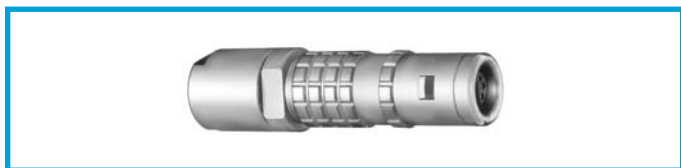

### FFA Straight plug with oversize cable collet

Reference		Dimensions (mm)						Availability
Model	Series	A	B	L	M	S1	S2	
FFA	1E	13	14.5	55	41	12	12	○
FFA	2E	16	17.0	65	49	15	15	○
FFA	3E	19	22.0	80	60	19	19	○
FFA	4E	25	36.0	105	84	30	32	○

**Note:** The fitting of oversize collets onto this model allows them to be fitted to the cables that can be accommodated by the next housing size up.

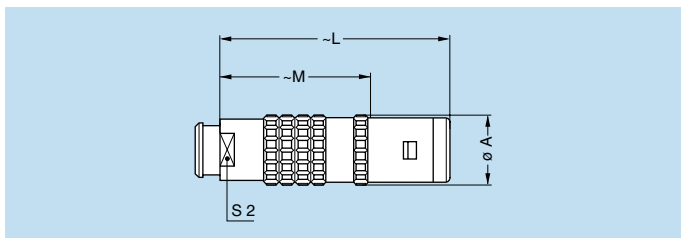
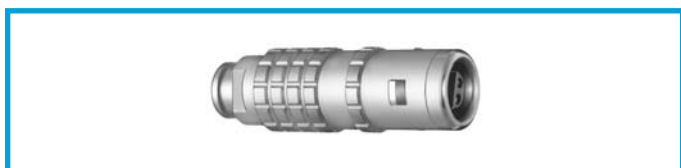

### FFA Straight plug, cable collet and nut for fitting a bend relief

Reference		Dimensions (mm)				Availability
Model	Series	A	L	M	S2	
FFA	0E	11	34	23.0	7	●
FFA	1E	13	42	28.0	9	●
FFA	2E	16	52	36.0	12	●
FFA	3E	19	60	40.0	15	●
FFA	4E	25	71	50.5	19	○

**Note:** The bend relief must be ordered separately (see page 91).

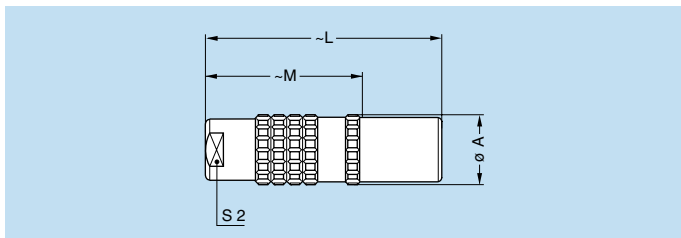
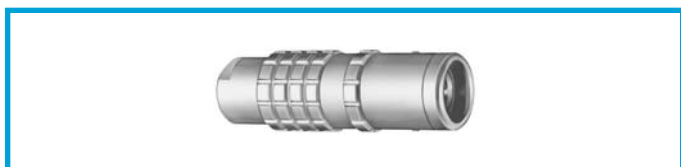

### FFF Straight plug non-latching, cable collet

Reference		Dimensions (mm)				Availability
Model	Series	A	L	M	S2	
FFF	0E	11	34	23	8	○
FFF	1E	13	42	28	9	○

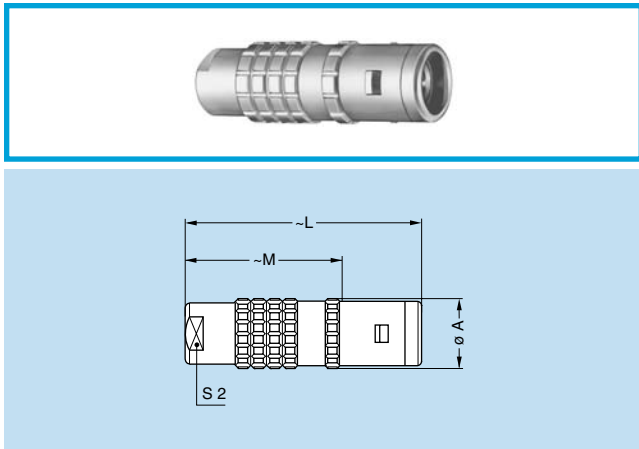

### FFP Straight plug, cable collet and inner anti-rotating device

Reference		Dimensions (mm)				Availability
Model	Series	A	L	M	S2	
FFP	3E	19	61	41.0	15	○
FFP	4E	25	71	50.5	19	○

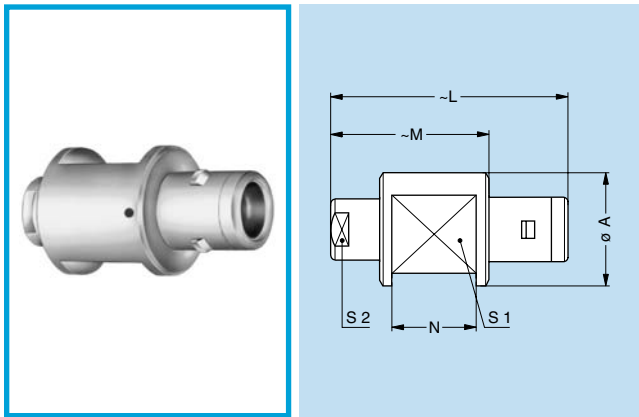

### FZP Straight plug for remote handling, cable collet and inner anti-rotating device

Reference		Dimensions (mm)						Availability
Model	Series	A	L	M	N	S1	S2	
FZP	1E	20	42	28.0	15.0	15	9	○
FZP	2E	22	52	36.0	16.0	16	12	○
FZP	3E	23	61	41.0	20.0	19	15	○
FZP	4E	32	71	50.5	29.0	25	19	○
FZP	5E	44	92	67.0	39.5	36	32	○

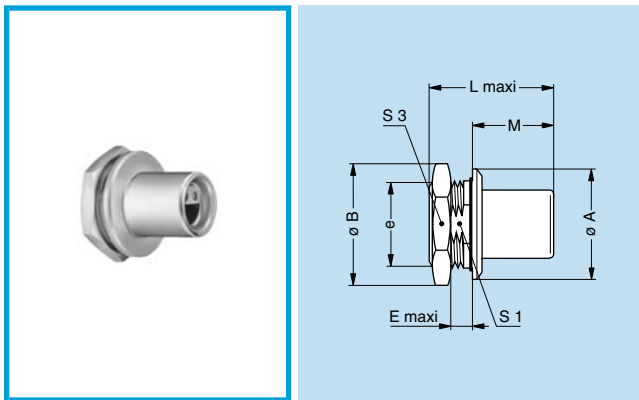

### FAA Fixed plug non-latching, nut fixing

Reference		Dimensions (mm)									Availability
Model	Series	A	B	e	E	L	L <sup>1)</sup>	M	S1	S3	
FAA	0E	18	19.5	M14x1.0	3.5	19.5	19.5	13.0	12.5	17	○
FAA	1E	20	21.5	M16x1.0	3.5	23.0	23.0	16.0	14.5	19	○
FAA	2E	25	27.5	M20x1.0	4.0	27.0	27.0	18.0	18.5	24	○
FAA	3E	31	34.5	M24x1.0	4.5	32.5	32.5	22.5	22.5	30	○

 Panel cut-out: **P1**

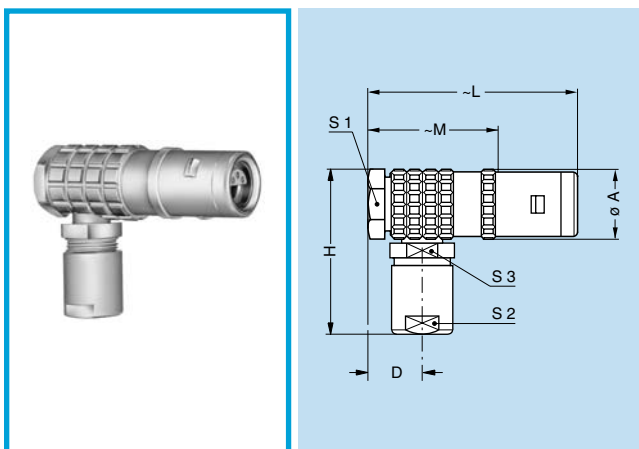
 Note: <sup>1)</sup> Single contact model

### FLA Elbow (90°) plug, cable collet

Reference		Dimensions (mm)								Availability
Model	Series	A	D	H	L	M	S1	S2	S3	
FLA	0E	11.5	7.6	27	36	25.0	10	8	8	○
FLA	1E	14.0	8.8	33	43	29.0	12	9	10	○
FLA	2E	17.5	10.5	40	51	35.0	15	12	13	○
FLA	3E	21.0	11.5	47	60	40.0	18	15	15	○
FLA	4E	27.5	15.5	57	72	51.5	24	19	20	○

● Standard, typically 0-6 weeks delivery for quantities of 250 or less.

○ Non-standard product, contact LEMO USA, typically 6-12 weeks delivery for quantities of 250 or less.

Non-standard product is defined as any product which contains one or more components which are not standard.

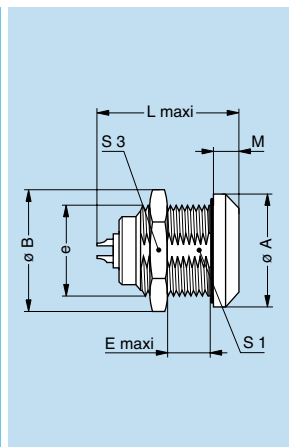

### ERA Fixed receptacle, nut fixing

Reference		Dimensions (mm)										Availability
Model	Series	A	B	e	E	L	L <sup>1)</sup>	M	S1	S3		
ERA	0E	18	19.5	M14x1.0	7.0	19.5	20.5	4.0	12.5	17	○	
ERA	1E	20	21.5	M16x1.0	9.0	24.0	25.3	4.5	14.5	19	○	
ERA	2E	25	27.5	M20x1.0	9.0	28.5	30.0	5.0	18.5	24	○	
ERA	3E	31	34.5	M24x1.0	11.0	34.0	35.0	6.0	22.5	30	○	
ERA	4E	37	40.5	M30x1.0	9.0	36.0	38.0	6.5	28.5	36	○	
ERA	5E	55	54.0	M45x1.5	10.0	44.5	78.0	9.0	42.5	-	○	
EGG <sup>2)</sup>	6E	65	65.0	M55x2.0	10.5	48.5	-	10.0	52.0	-	○	

Panel cut-out: **P1**

**Note:** 1) Single contact model

**Note:** 2) With key (G). The 5E and 6E series are delivered with a round nut.

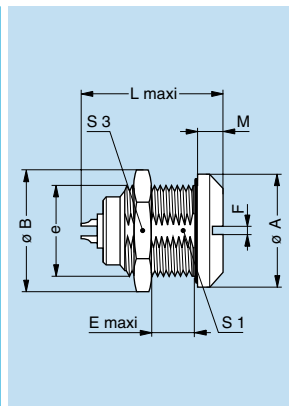

### ERC Fixed receptacle, nut fixing with slot in the flange

Reference		Dimensions (mm)										Availability
Model	Series	A	B	e	E	F	L	L <sup>1)</sup>	M	S1	S3	
ERC	0E	18	19.5	M14x1.0	7	1.5	19.5	20.5	4.0	12.5	17	○
ERC	3E	31	34.5	M24x1.0	11	3.0	34.0	35.0	6.0	22.5	30	○
ERC	4E	37	41.5	M30x1.0	9	3.0	36.0	38.0	6.5	28.5	36	○

Panel cut-out: **P1**

**Note:** 1) Single contact model.

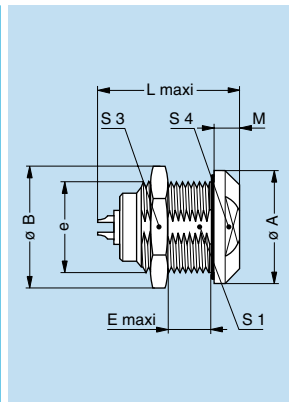

### ERB Fixed receptacle, nut fixing with two flats in the flange

Reference		Dimensions (mm)										Availability
Model	Series	A	B	e	E	L	L <sup>1)</sup>	M	S1	S3	S4	
ERB	0E	18	19.5	M14x1.0	7	19.5	20.5	4.0	12.5	17	14	○
ERB	1E	20	21.5	M16x1.0	9	24.0	25.3	4.5	14.5	19	17	○
ERB	2E	25	27.5	M20x1.0	9	28.5	30.0	5.0	18.5	24	20	○
ERB	3E	31	34.5	M24x1.0	11	34.0	35.0	6.0	22.5	30	24	○

Panel cut-out: **P1**

**Note:** 1) Single contact model.

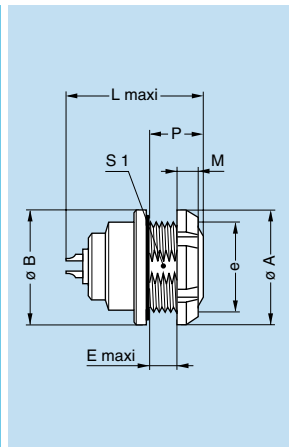

### EEP Fixed receptacle, nut fixing (back panel mounting)

Reference		Dimensions (mm)									Availability
Model	Series	A	B	e	E	L	L <sup>1)</sup>	M	P	S1	
EEP	0E	18	18	M14x1.0	3.4	19.5	20.5	3.5	7	12.5	○
EEP	1E	20	20	M16x1.0	6.5	24.0	25.3	3.5	10	14.5	○
EEP	2E	25	25	M20x1.0	5.0	28.5	30.0	3.5	10	18.5	○
EEP	3E	30	31	M24x1.0	7.0	34.0	35.0	4.5	12	22.5	○

Panel cut-out: **P1**

**Note:** 1) Single contact model.

**Note:** The 3E series is delivered with a conical nut.

● Standard, typically 0-6 weeks delivery for quantities of 250 or less.  
 ○ Non-standard product, contact LEMO USA, typically 6-12 weeks delivery for quantities of 250 or less.  
 Non-standard product is defined as any product which contains one or more components which are not standard.

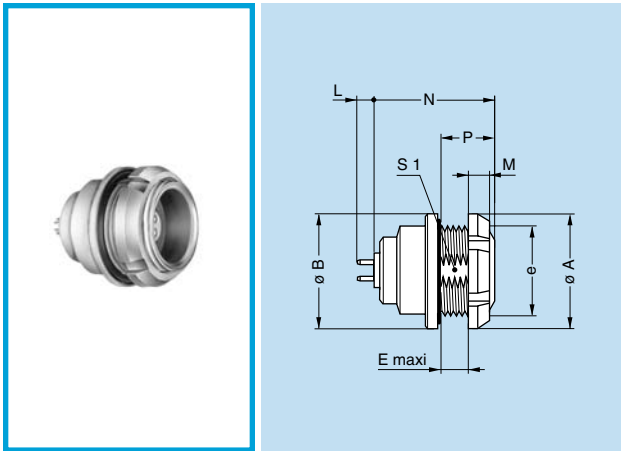

### EEP Fixed receptacle, nut fixing, with straight contact for printed circuit (back panel mounting)

Reference		Dimensions (mm)								Availability
Model	Series	A	B	e	E	M	N	P	S1	
EEP	0E	18	18	M14x1.0	3.4	3.5	18.4	7	12.5	○
EEP	1E	20	20	M16x1.0	6.2	3.5	23.5	10	14.5	○
EEP	2E	25	25	M20x1.0	5.0	3.5	25.5	10	18.5	○
EEP	3E	30	31	M24x1.0	7.0	4.5	30.5	12	22.5	○

 Panel cut-out: **P1**

 PCB drilling pattern: **P21**

**Note:** This contact type is available for all E●● receptacle models. See page 109 for table of available types. Length «L» depends on the number of contacts, see PCB drilling pattern on page 109. The 3E series is delivered with a conical nut.

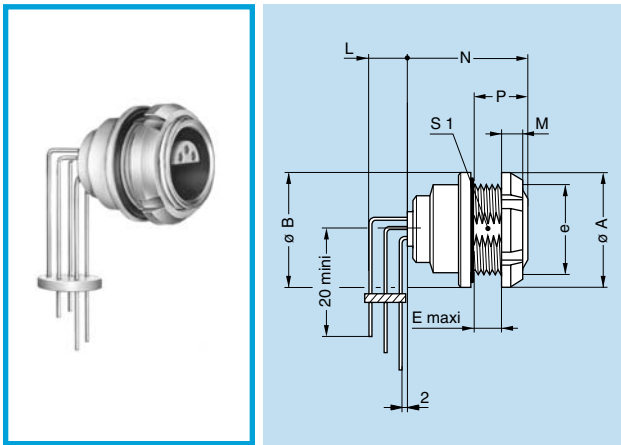

### EEP Fixed receptacle, nut fixing, with elbow (90°) contacts for printed circuit (back panel mounting)

Reference		Dimensions (mm)								Availability
Model	Series	A	B	e	E	M	N	P	S1	
EEP	2E	25	25	M20x1.0	5	3.5	24.5	10	18.5	○

 Panel cut-out: **P1**

 PCB drilling pattern: **P24**

**Note:** This contact type is available for all back panel mounting receptacle types. See page 110 for available types. Length «L» depends on the number of contacts, see PCB drilling pattern on page 110.

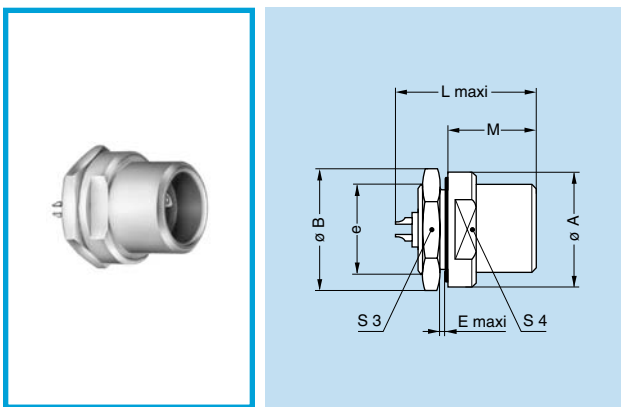

### EHP Fixed receptacle, nut fixing, protruding shell

Reference		Dimensions (mm)									Availability
Model	Series	A	B	e	E	L	L <sup>1)</sup>	M	S3	S4	
EHP	0E	18	19.5	M14x1.0	1.5	19.5	20.5	10.5	17	15	○
EHP	1E	20	21.5	M16x1.0	1.5	24.0	25.3	15.5	19	17	○
EHP	2E	25	27.5	M20x1.0	2.0	28.5	30.0	17.0	24	20	○

 Panel cut-out: **P1**

**Note:** 1) Single contact model.

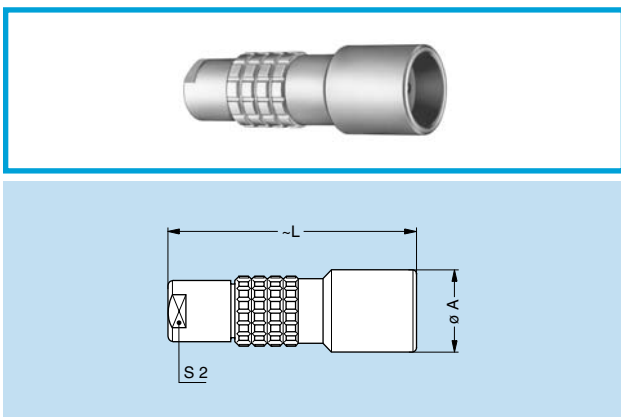

### PCA Free receptacle, cable collet

Reference		Dimensions (mm)			Availability
Model	Series	A	L	S2	
PCA	0E	13	34.0	8	○
PCA	1E	15	45.0	9	○
PCA	2E	19	54.0	12	○
PCA	3E	23	65.0	15	○
PCA	4E	29	75.5	19	○
PCA	5E	42	95.0	32	○
PHG <sup>1)</sup>	6E	52	125.0	38	○

**Note:** 1) With key (G).

● Standard, typically 0-6 weeks delivery for quantities of 250 or less.  
 ○ Non-standard product, contact LEMO USA, typically 6-12 weeks delivery for quantities of 250 or less.  
 Non-standard product is defined as any product which contains one or more components which are not standard.

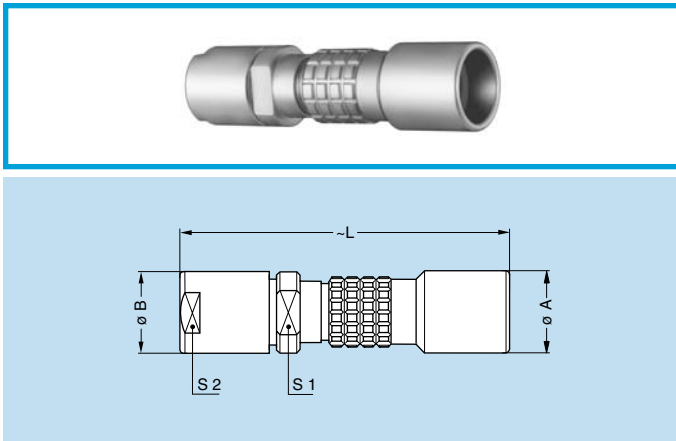

**PCA Free receptacle with oversized cable collet**

Reference		Dimensions (mm)					Availability
Model	Series	A	B	L	S1	S2	
PCA	1E	15	14.5	58.0	12	12	○
PCA	2E	19	17.0	67.0	15	15	○
PCA	3E	23	22.0	84.0	19	19	○
PCA	4E	29	36.0	109.0	30	32	○

**Note:** The fitting of oversized collets onto this model allows them to be fitted to the cables that can be accommodated by the next housing size up.

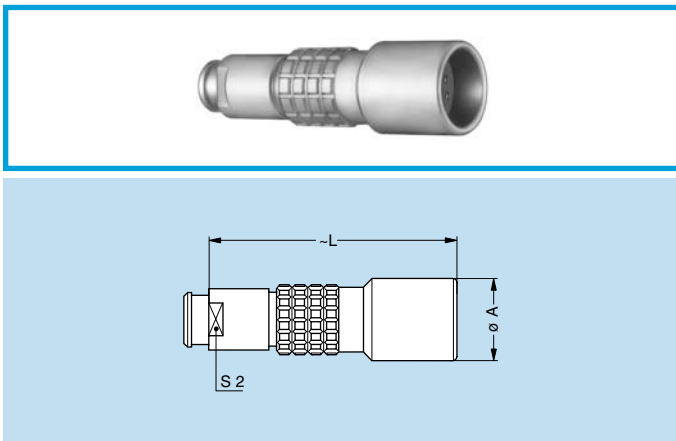

**PCA Free receptacle, cable collet and nut for fitting a bend relief**

Reference		Dimensions (mm)			Availability
Model	Series	A	L	S2	
PCA	0E	13	34.0	7	○
PCA	1E	15	45.0	9	○
PCA	2E	19	54.0	12	○
PCA	3E	23	64.0	15	○
PCA	4E	29	75.5	19	○

**Note:** The bend relief must be ordered separately (see page 91).

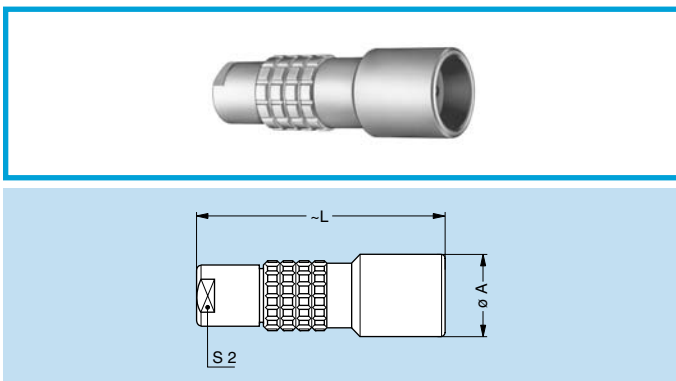

**PCP Free receptacle, cable collet and inner anti-rotating device**

Reference		Dimensions (mm)			Availability
Model	Series	A	L	S2	
PCP	3E	23	65.0	15	○
PCP	4E	29	75.5	19	○

● Standard, typically 0-6 weeks delivery for quantities of 250 or less.  
 ○ Non-standard product, contact LEMO USA, typically 6-12 weeks delivery for quantities of 250 or less.  
 Non-standard product is defined as any product which contains one or more components which are not standard.

### PSA Fixed receptacle, nut fixing, cable collet

Reference		Dimensions (mm)									Avail-ability
Model	Series	A	B	e	E	L	M	S1	S2	S3	
PSA	0E	18	19.5	M14x1.0	7.0	34.0	4.0	12.5	8	17	○
PSA	1E	20	21.5	M16x1.0	9.0	45.0	4.5	14.5	9	19	○
PSA	2E	25	27.5	M20x1.0	9.0	54.0	5.0	18.5	12	24	○
PSA	3E	31	34.5	M24x1.0	11.0	65.0	6.0	22.5	15	30	○
PSA	4E	37	40.5	M30x1.5	9.0	75.5	6.5	28.5	19	36	○
PSA	5E	51	54.0	M45x1.5	10.0	95.0	9.0	-	32	54	○
PKG <sup>1)</sup>	6E	65	65.0	M55x2.0	10.5	125.0	10.0	-	38	-	○

Panel cut-out: **P1**

**Note:** <sup>1)</sup> With key (G).  
The 5E and 6E series are delivered with a round nut.

### PSP Fixed receptacle, nut fixing, cable collet and inner anti-rotating device

Reference		Dimensions (mm)									Avail-ability
Model	Series	A	B	e	E	L	M	S1	S2	S3	
PSP	3E	31	34.5	M24x1.0	11.0	65.0	6.0	22.5	15	30	○
PSP	4E	37	41.5	M30x1.5	9.0	75.5	6.5	28.5	19	36	○
PSP	5E	51	54.0	M45x1.5	10.0	95.0	9.0	-	32	54	○

Panel cut-out: **P1**

**Note:** The 5E series are delivered with a round nut.

### RMA Free coupler

Reference		Dim. (mm)		Avail-ability
Model	Series	A	L	
RMA	0E	14	30	○
RMA	1E	16	40	○
RMA	2E	20	44	○
RMA	3E	25	54	○
RMA	4E	30	57	○
RMA	5E	44	67	○

**Note:** See page 77 for the available plug and contact configurations and in order to ensure correct contact alignment.

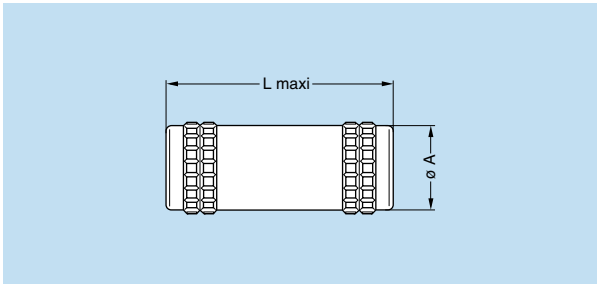
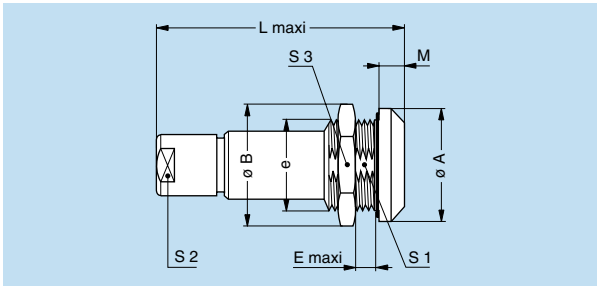
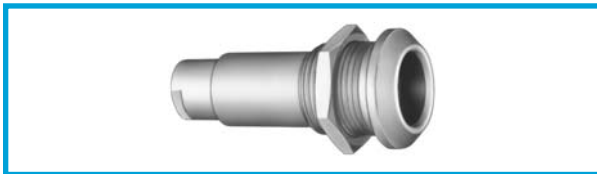
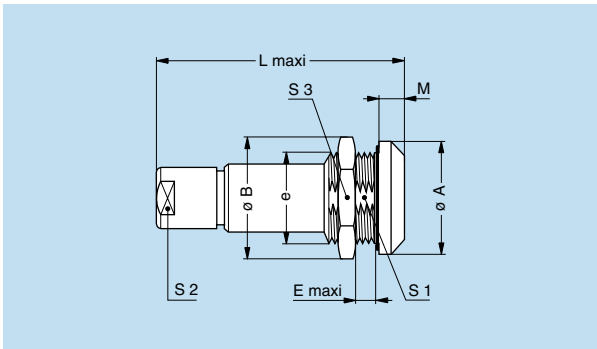
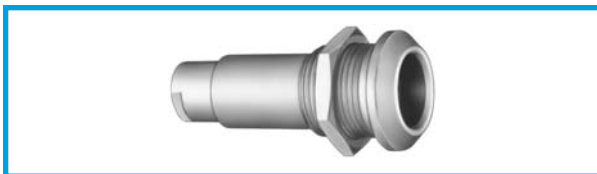

## Watertight or vacuum-tight models

HGP, EBR and SWH receptacle or coupler models allow the device on which they are fitted to reach a protection index of IP 68 as per IEC 60529. They are fully compatible with plugs of the same series and are widely used for portable radios, military, laboratory equipment, aviation, etc. These models are identified by a letter «P» at the end of the reference.

Most of these models are also available in a vacuum-tight version. Such models are identified by an additional letter «V» at the end of the part number (certificate on request).

Epox resin is used to seal these models.

Part number example:

Watertight receptacle – HGP.1E.304.CLLP  
 Vacuum-tight receptacle – HGP.1E.304.CLLPV

## Technical Characteristics

### Mechanical and Climatic

Characteristics	Value	Standard
Endurance	> 5000 cycles	IEC 60512-5 test 9a
Humidity	up to 95% at 140° F	
Temperature range	-4° F/+176° F	
Salt spray corrosion test	> 144h	IEC 60512-6 test 11f
Protection index (mated)	IP 68	IEC 60529
Climatic category	20/80/21	IEC 60068-1
Leakage rate (He) <sup>1)</sup>	< 10 <sup>-7</sup> mbar.l.s <sup>-1</sup>	IEC 60512-7 test 14b
Maximum operating pressure <sup>2)</sup>	0E	60 bars
	1E	60 bars
	2E	40 bars
	3E	30 bars
	4E	15 bars
	5E	5 bars
6E	5 bars	IEC 60512-7 test 14d

**Note:**

<sup>1)</sup> Only for vacuum-tight models.

<sup>2)</sup> This value corresponds to the maximum allowed pressure difference for the assembled receptacle.

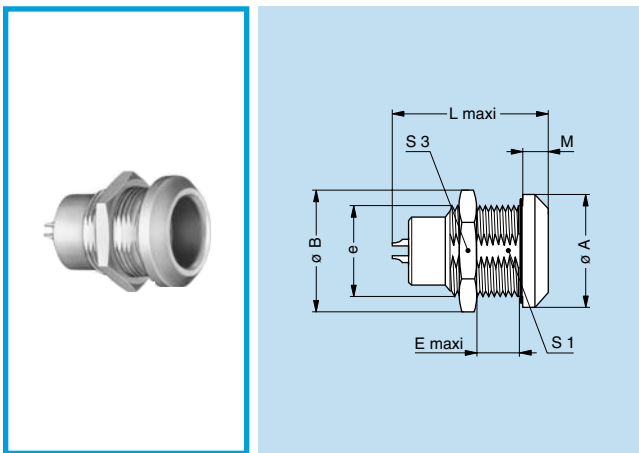

### HGP Fixed receptacle, nut fixing, watertight or vacuum-tight

Reference		Dimensions (mm)									Availability
Model	Series	A	B	e	E	L	L <sup>1)</sup>	M	S1	S3	
HGP	0E	18	19.5	M14x1.0	7.0	23.5	22.0	4.0	12.5	17	○
HGP	1E	20	21.5	M16x1.0	9.0	28.0	28.0	4.5	14.5	19	○
HGP	2E	25	27.5	M20x1.0	10.5	32.5	28.0	5.0	18.5	24	○
HGP	3E	31	34.5	M24x1.0	15.5	39.5	38.5	6.0	22.5	30	○
HGP	4E	37	40.5	M30x1.0	17.5	43.0	44.0	6.5	28.5	36	○
HGP	5E	55	54.0	M45x1.5	20.0	52.0	76.0	9.0	42.5	–	○
HGP <sup>1)</sup>	6E	65	65.0	M55x2.0	20.5	52.0	–	10.0	52.0	–	○

Panel cut-out: **P1**

**Note:** <sup>1)</sup> Single contact model

**Note:** <sup>1)</sup> With key (G). The 5E and 6E series are delivered with a round nut.

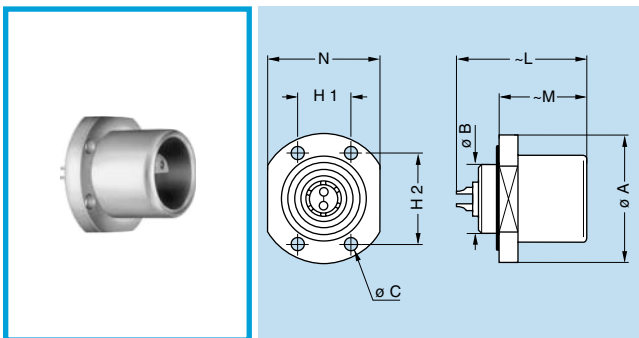

### EBR Fixed receptacle with round flange, watertight, protruding shell and screw fixing

Reference		Dimensions (mm)									Availability
Model	Series	A	B	C	H1	H2	L	L <sup>1)</sup>	M	N	
EBR	2E	28	19	2.8	11.8	20.4	32.5	28.0	19	15	○

Panel cut-out: **P6**

**Note:** <sup>1)</sup> Single contact model.

This model is only available in a watertight version.

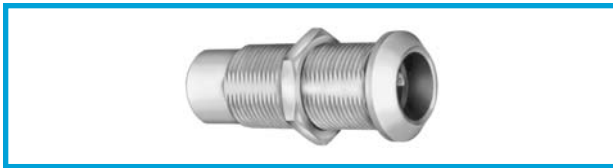

### SWH Fixed coupler, nut fixing, watertight or vacuum-tight

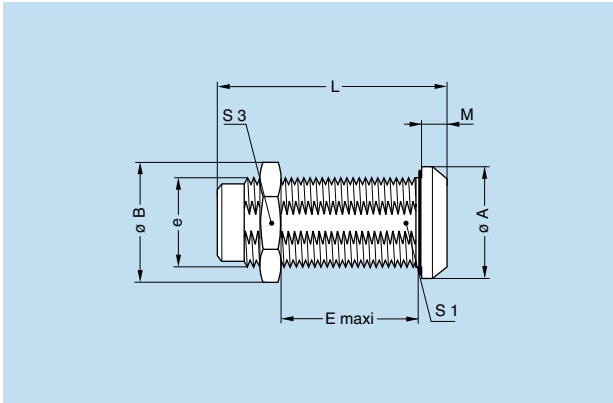

Reference		Dimensions (mm)								Availability
Model	Series	A	B	e	E	L	M	S1	S3	
SWH	0E	18	19.5	M14x1.0	22.5	36.0	4.0	12.5	17	○
SWH	1E	20	21.5	M16x1.0	30.5	47.0	4.5	14.5	19	○
SWH	2E	25	27.5	M20x1.0	28.0	52.4	5.0	18.5	24	○
SWH	3E	31	34.5	M24x1.0	33.0	64.2	6.0	22.5	30	○
SWH	4E	37	40.5	M30x1.0	44.5	70.0	6.5	28.5	36	○
SWH	5E	55	54.0	M45x1.5	47.0	81.0	9.0	42.5	–	○
SWH <sup>1)</sup>	6E	65	65.0	M55x2.0	12.0	76.0	10.0	–	–	○











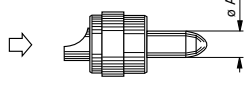
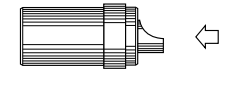







Panel cut-out: **P1**

**Note:** 1) With key (G). The 5E and 6E series are delivered with a round nut. See page 77 for the available plug and contact configurations and in order to ensure correct contact alignment.



# ● Type

## Single contact

	 Male solder contacts		 Female solder contacts		Reference	ø A (mm)	AWG max. (solid)	AWG max. (stranded)	Contact type availability		Test voltage (kV rms) <sup>1)</sup>	Test voltage (kV dc) <sup>1)</sup>	Rated current (A) <sup>1)</sup>
	Solder	Crimp											
<b>0E</b>			116	1.6	16	18	○ <sup>2)</sup>	-	1.7	2.4	12		
<b>1E</b>			120	2.0	14	16	○ <sup>2)</sup>	-	1.8	2.7	18		
			130	3.0	10	12	○	-	1.5	2.1	25		
<b>2E</b>			130	3.0	10	12	○	-	2.1	3.0	30		
			140	4.0	10	10	○	-	1.7	2.4	40		
<b>3E</b>			140	4.0	10	10	○	-	2.3	3.3	43		
			160	6.0	-	8	○	-	1.7	2.4	65		
<b>4E</b>			160	6.0	-	8	○	-	2.7	3.9	70		
<b>5E</b>			112	12.0	-	6	○	-	1.5	2.1	230		

**Note:** 1) See calculation method, caution and suggested standard on page 11.

2) Also available with reversed contacts: plug = female, receptacle = male.

● Standard, typically 0-6 weeks delivery for quantities of 250 or less.  
 ○ Non-standard product, contact LEMO USA, typically 6-12 weeks delivery for quantities of 250 or less.  
 Non-standard product is defined as any product which contains one or more components which are not standard.

## Single contact high voltage

	Male solder contacts	Female solder contacts	Reference	ø A (mm)	AWG max. (solid)	AWG max. (stranded)	Contact type availability		HV contact gender <sup>2)</sup>	Cable dielectric ø max. (mm)	Standard insulator material <sup>3)</sup>	Test voltage (kV dc) <sup>1)</sup>	Rated current (A) <sup>1)</sup>
							Solder	Crimp					
0E			403	0.9	20	22 <sup>5)</sup>	○	-	A L	2.9	T	6	4
			405	0.7	24	26	○	-	A	2.9	L	12	4
1E			405	1.3	18	20 <sup>5)</sup>	○	-	A L	4.0	T	10.5	8
			408	0.9	20	22 <sup>5)</sup>	○	-	A	4.0	L	18	6
2E			408	2.0	14	16	○	-	A L	5.1	T	12	10
3E			405	4.0	10	12	○	-	A	7.5	T	10.5	15
			410	2.0	12	14	○	-	A L	7.3	T	15	10
			415	1.3	16	18	○	-	A L	7.3	T	21	8
4E			410	2.5	6	8	○	-	A	9.5	T	15	12

**Note:**

<sup>2)</sup> A = male for plug; female for socket, L = female for plug; male for socket





<sup>3)</sup> L = Peek, T = PTFE

<sup>4)</sup> See calculation method, caution and suggested standard on page 11

<sup>5)</sup> For a given AWG, the diameter of some stranded conductor designs is larger than the solder cup diameter.

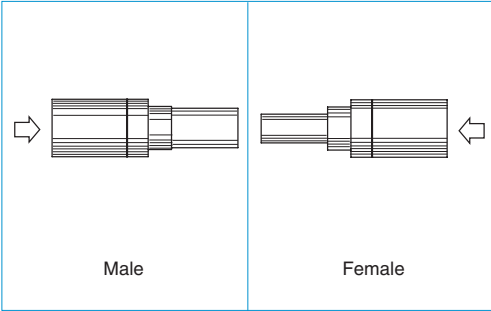
Make sure that the maximum conductor diameter is smaller than øC on page 9 (for solder), and page 10 (for crimp).

## Coaxial

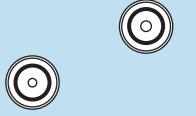
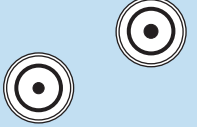
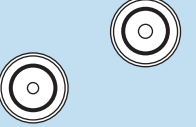
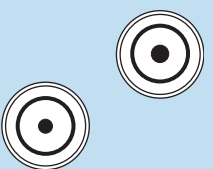
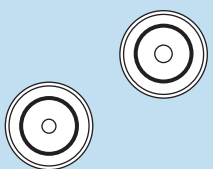
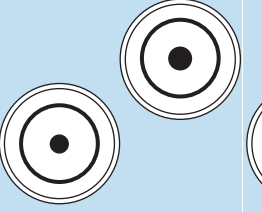
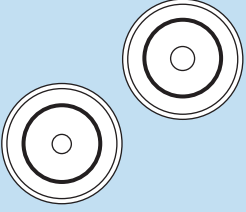
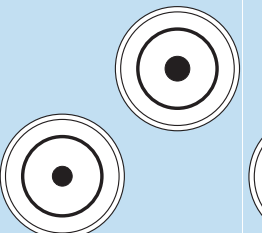
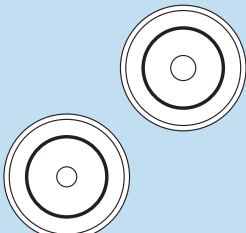
			Reference	Impedance	Male or female contact available	Cable Group	VSWR (GHz)	Test Voltage		Rated current (Amps)	Availability
	Male	Female						AC (V)	DC (V)		
<b>0E</b>			250	50	M/F	1,2,3,4	1.02 +.25f	3000	4200	6	○
<b>1E</b>			250	50	M/F	1,2,3 4,6	1.01 +.08f	3000	4200	12	○
			275	75	M/F	5,6,7	1.02 +.08f	2400	3300	10	○
<b>2E</b>			250	50	M/F	6,7	1.02 +.95f	3000	4200	15	○
			275	75	M/F	6,7	1.02 +.03f	1500	2100	12	○
<b>3E</b>			250	50	M/F	8	1.06 +.5f	3000	4200	26	○
			275	75	M/F	8	1.04 +.05f	2700	3900	15	○
<b>4E</b>			250	50		8,9	1.01 +1.9f	2100	3000	36	○
			275	75	M/F	8,9,0	1.01 .12f	1800	2700	26	○
<b>5E</b>			250	50		9	1.02 +2.3f	3000	4200	45	○
			275	75		9,0	1.01 +.7f	3000	4200	36	○

1) The cable group corresponding to the chosen cable must be written in the Variant position of the part number.

## Triaxial

	Male	Female	Reference	Impedance	Male or female contact available	Cable Group	VSWR (GHz)	Rated current (Amps)	Availability
<b>0E</b>			650	50	M/F	1,2	1.03 +.34f	6	○
<b>1E</b>			650	50	M/F	1,2	1.01 +.17f	6	○
<b>2E</b>			650	50	M/F	2,3,4	1.01 +.3f	12	○
			675	75	M/F	4,6	1.02 +.07f	6	○
<b>3E</b>			650	50	M/F	3,4,5	1.01 +.27f	15	○
			675	75	M/F	4,5	1.02 +.05f	6	○
<b>4E</b>			650	50	M/F	4,5	1.01 +.38f	26	○
			675	75	M/F	4,5,7	1.01 +.14f	15	○

## Recommended coaxial cables

Type	Group 1)								Type	Group 1)									Type	Group 1)					
	1	2	3	4	5	6	7	8		0	1	2	3	4	5	6	7	8		9	2	3	4	5	6
RG.11A/U								■	RG.178B/U	■									RG.302/U						■
RG.12A/U									RG.179B/U						■				RG.316/U		■				
RG.58C/U						■			RG.187A/U							■			RG.400/U						■
RG.59B/U							■		RG.188 A/U		■								HF-2114 Datwyler			■			
RG.115A/U								■	RG.196A/U	■									HF-5408/1 Datwyler						■
RG.122/U				■					RG.213/U								■		2YCCY .4/2.4 Siemens					■	
RG.142B/U						■			RG.214/U									■	CCE.99.281.505 LEMO		■				
RG.144/U								■	RG.216/U									■	CCH.99.281.505 LEMO		■				
RG.165/U								■	RG.223/U									■							
RG.174 A/U			■						RG.225/U									■							

## Recommended triaxial cables

Type	Group 1)					Type	Group 1)			
	1	2	3	4	5		4	5	6	7
CTA.99.290.803 LEMO	■					HF-2426 Datwyler	■			
CTD.99.391.505 LEMO		■				CTC.99.371.603 LEMO			■	
9222 Belden				■		12765700 F&G	■			
21.738 Amphenol				■		9627 Belden		■		
118202 Filotex					■	10069-C-G20 BIW		■		
21.204 Amphenol					■	12766400 F&G				■
HF-2318 Datwyler					■	12766601 F&G				■
8215 Belden					■	8233 Belden				■
8232 Belden					■	9888 Belden				■

● Standard, typically 0-6 weeks delivery for quantities of 250 or less.  
 ○ Non-standard product, contact LEMO USA, typically 6-12 weeks delivery for quantities of 250 or less.  
 Non-standard product is defined as any product which contains one or more components which are not standard.

## Multicontact

	Male solder contacts	Female solder contacts	Reference	Number of contacts	ø A (mm)	Solder		Contact type availability				Test voltage (kV rms) <sup>1)2)</sup>	Test voltage (kV dc) <sup>1)2)</sup>	Rated current (A) <sup>1)</sup>
						AWG max. (solid)	AWG max. (stranded)	Solder	Crimp	Printed circuit (straight)	Printed circuit (elbow)			
<b>0E</b>			302	2	0.9	22	22 <sup>6)</sup>	○	○	○	○	1.5	2.1	10 <sup>3)</sup>
			303	3	0.7	24	26	○	-	○	○	1.0	1.5	7 <sup>3)</sup>
			304	4	0.7	24	26	○	-	○	○	1.0	1.5	7 <sup>3)</sup>
<b>1E</b>			302	2	1.3	20	20 <sup>6)</sup>	○	○	○	○	1.2	1.8	15 <sup>3)</sup>
			303	3	0.9	22	22 <sup>6)</sup>	○	-	○	○	1.2	1.8	10 <sup>3)</sup>
			304	4	0.9	22	22 <sup>6)</sup>	○	○	○	○	1.2	1.8	10 <sup>3)</sup>
			305	2 3	0.9 0.7	22 24	22 <sup>6)</sup> 26	○	-	○	○	1.5 1.5	2.1 2.1	10 <sup>3)</sup> 7 <sup>3)</sup>
			306	6	0.7	24	26	○	-	○	○	1.5	2.1	7 <sup>3)</sup>
			307	3 4	1.3 0.9	20 22	20 <sup>6)</sup> 22 <sup>6)</sup>	○	-	○	○	0.8 0.8	1.2 1.2	12 <sup>3)</sup> 9 <sup>3)</sup>
<b>2E</b>			302	2	1.6	16	18	○	-	○	○	1.7	2.4	20 <sup>4)</sup>
			303	3	1.3	20	20 <sup>6)</sup>	○	-	○	○	1.5	2.1	15 <sup>4)</sup>
			304	4	1.3	20	20 <sup>6)</sup>	○	-	○	○	1.7	2.4	15 <sup>4)</sup>
			305	5	1.3	20	20 <sup>6)</sup>	○	-	○	○	1.5	2.1	13 <sup>4)</sup>
			306	6	1.3	20	20 <sup>6)</sup>	○	○ <sup>5)</sup>	○	○	1.5	2.1	12
			307	3 4	1.3 0.9	20 22	20 <sup>6)</sup> 22 <sup>6)</sup>	○	-	○	○	0.8 0.8	1.2 1.2	12 <sup>3)</sup> 9 <sup>3)</sup>
			308	8	0.9	22	22 <sup>6)</sup>	○	-	○	○	0.8	1.2	9 <sup>3)</sup>
			310	10	0.9	22	22 <sup>6)</sup>	○	-	○	○	0.8	1.2	7 <sup>3)</sup>
			311	10	0.9	22	22 <sup>6)</sup>	○	-	○	○	0.8	1.2	7 <sup>3)</sup>
<b>3E</b>			302	2	2.0	14	16	○	-	○	-	3.0	4.2	23
			303	3	2.0	14	16	○	-	○	-	1.5	2.1	20
			304	4	2.0	14	16	○	-	○	-	1.5	2.1	18
			305	2 3	2.0 1.3	14 20	16 20 <sup>6)</sup>	○	-	○	-	1.5 1.5	2.1 2.1	18 14
			306	6	1.3	20	20 <sup>6)</sup>	○	-	○	-	2.1	3.0	14
			307	7	1.3	20	20 <sup>6)</sup>	○	-	○	-	1.0	1.5	12
			308	7	1.3	20	20 <sup>6)</sup>	○	-	○	-	1.0	1.5	12

**Note:**

- 1) See calculation method, caution and suggested standard on page 11.
- 2) Lowest measured value; contact to contact or contact to shell.
- 3) Rated current = 6A for receptacle with elbow (90°) contacts for printed circuit.
- 4) Rated current = 12A for receptacle with elbow (90°) contacts for printed circuit.
- 5) Only for FFL model.

6) For a given AWG, the diameter of some stranded conductor designs is larger than the solder cup diameter. Make sure that the maximum conductor diameter is smaller than øC on page 9 (for solder), and page 10 (for crimp).

● Standard, typically 0-6 weeks delivery for quantities of 250 or less.  
 ○ Non-standard product, contact LEMO USA, typically 6-12 weeks delivery for quantities of 250 or less.  
 Non-standard product is defined as any product which contains one or more components which are not standard.

## Multicontact

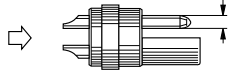
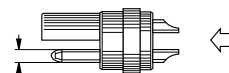
	 Male solder contacts		 Female solder contacts		Reference	Number of contacts	ø A (mm)	Solder		Contact type availability				Test voltage (kV rms) <sup>1) 2)</sup>	Test voltage (kV dc) <sup>1) 2)</sup>	Rated current (A) <sup>1)</sup>
	AWG max. (solid)	AWG max. (stranded)	Solder	Crimp				Printed circuit (straight)	Printed circuit (elbow)							
<b>3E</b>					308	8	1.3	20	20 <sup>3)</sup>	○	-	○	○	1.0	1.5	10
					310	10	1.3	20	20 <sup>3)</sup>	○	-	○	○	1.0	1.5	9
					312	12	0.9	22	22 <sup>3)</sup>	○	-	○	○	1.5	2.1	8
					313	13	0.9	22	22 <sup>3)</sup>	○	-	○	○	1.5	2.1	8
					314	14	0.9	22	22 <sup>3)</sup>	○	-	○	○	1.5	2.1	7
					316	16	0.9	22	22 <sup>3)</sup>	○	-	○	○	1.0	1.5	7
					318	18	0.9	22	22 <sup>3)</sup>	○	-	○	○	1.0	1.5	6
<b>4E</b>					302	2	4.0	10	10	○	-	○	-	2.1	3.0	35
					303	3	3.0	10	12	○	-	○	-	2.1	3.0	25
					304	4	3.0	10	12	○	-	○	-	2.1	3.0	22
					305	2 3	3.0 2.0	10 14	12 16	○	-	○	-	2.1 2.1	3.0 3.0	22 16
					306	6	2.0	14	16	○	-	○	-	2.1	3.0	16
					307	3 4	2.0 1.3	14 20	16 20 <sup>3)</sup>	○	-	○	-	2.1 2.1	3.0 3.0	16 13
					308	8	1.3	20	20 <sup>3)</sup>	○	-	○	-	2.7	3.9	13
					309	9	1.3	20	20 <sup>3)</sup>	○	-	○	-	2.1	3.0	12
					310	10	1.3	20	20 <sup>3)</sup>	○	-	○	-	2.1	3.0	11
					312	12	1.3	20	20 <sup>3)</sup>	○	-	○	-	2.1	3.0	9

Note: 1) See calculation method, caution and suggested standard on page 11.

2) Lowest measured value; contact to contact or contact to shell.

3) For a given AWG, the diameter of some stranded conductor designs is larger than the solder cup diameter. Make sure that the maximum conductor diameter is smaller than øC on page 9 (for solder), and page 10 (for crimp).

● Standard, typically 0-6 weeks delivery for quantities of 250 or less.

○ Non-standard product, contact LEMO USA, typically 6-12 weeks delivery for quantities of 250 or less.

Non-standard product is defined as any product which contains one or more components which are not standard.

## Multicontact

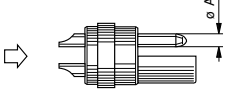
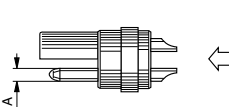
	 Male solder contacts		 Female solder contacts		Reference	Number of contacts	ø A (mm)	Solder		Contact type availability				Test voltage (kV rms) <sup>1) 2)</sup>	Test voltage (kV dc) <sup>1) 2)</sup>	Rated current (A) <sup>1)</sup>
	AWG max. (solid)	AWG max. (stranded)	Solder	Crimp				Printed circuit (straight)	Printed circuit (elbow)							
<b>4E</b>					314	14	1.3	20	20 <sup>3)</sup>	○	-	○	-	2.1	3.0	9
					316	16	0.9	22	22 <sup>3)</sup>	○	-	○	-	2.1	3.0	7
					318	18	0.9	22	22 <sup>3)</sup>	○	-	○	-	2.1	3.0	7
					320	20	0.9	22	22 <sup>3)</sup>	○	-	○	-	2.1	3.0	7
					322	22	0.9	22	22 <sup>3)</sup>	○	-	○	-	2.1	3.0	7
					324	24	0.9	22	22 <sup>3)</sup>	○	-	○	-	2.1	3.0	7
<b>5E</b>					302	2	6.0	-	8	○	-	-	-	3.7	5.2	50
					303	1 2	6.0 4.0	- 10	8 10	○	-	-	-	3.7 3.7	5.2 5.2	50 35
					304	4	4.0	10	10	○	-	-	-	3.7	5.2	35
					305	2 3	4.0 3.0	10 10	10 12	○	-	-	-	3.0 3.0	4.2 4.2	35 25
					306	6	3.0	10	12	○	-	-	-	3.0	4.2	25
					308	8	3.0	10	12	○	-	-	-	2.1	3.0	22
					310	10	2.0	14	16	○	-	-	-	2.1	3.0	18

**Note:** 1) See calculation method, caution and suggested standard on page 11.

2) Lowest measured value; contact to contact or contact to shell.

3) For a given AWG, the diameter of some stranded conductor designs is larger than the solder cup diameter.

Make sure that the maximum conductor diameter is smaller than øC on page 9 (for solder), and page 10 (for crimp).

● Standard, typically 0-6 weeks delivery for quantities of 250 or less.

○ Non-standard product, contact LEMO USA, typically 6-12 weeks delivery for quantities of 250 or less.

Non-standard product is defined as any product which contains one or more components which are not standard.

**Multicontact**

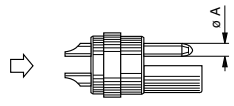
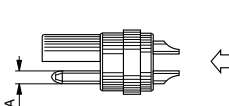
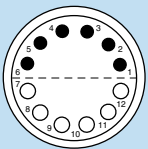
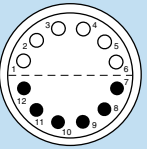
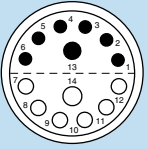
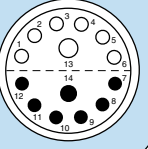
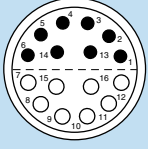
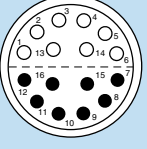
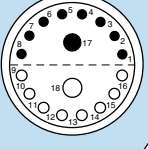
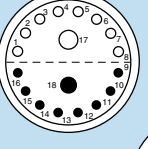
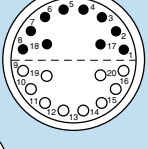
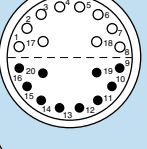
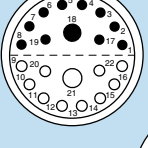
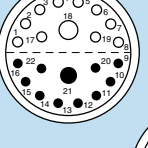
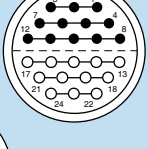
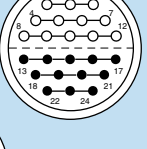
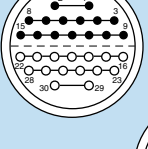
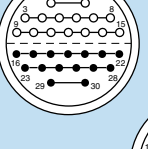
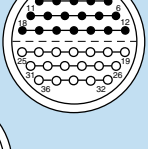
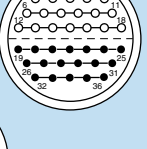
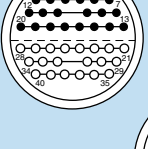
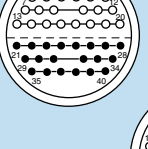
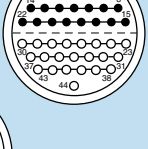
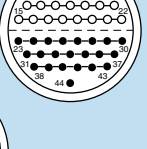
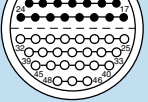
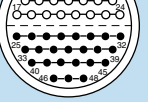
	 Male solder contacts		 Female solder contacts		Reference	Number of contacts	ø A (mm)	Solder		Contact type availability				Test voltage (kV rms) <sup>1) 2)</sup>	Test voltage (kV dc) <sup>1) 2)</sup>	Rated current (A) <sup>1)</sup>
	AWG max. (solid)	AWG max. (stranded)	Solder	Crimp				Printed circuit (straight)	Printed circuit (elbow)							
<b>5E</b>			312	12	2.0	14	16	○	-	-	-	2.1	3.0	18		
			314	2 12	3.0 2.0	10 14	12 16	○	-	-	-	1.8 1.8	2.4 2.4	20 15		
			316	16	2.0	14	16	○	-	-	-	1.8	2.4	15		
			318	2 16	3.0 1.6	10 16	12 18	○	-	-	-	1.8 1.8	2.4 2.4	18 11		
			320	20	1.6	16	18	○	-	-	-	1.8	2.4	11		
			322	2 20	3.0 1.6	10 16	12 18	○	-	-	-	1.8 1.8	2.4 2.4	16 9		
			324	24	1.6	16	18	○	-	-	-	2.7	3.9	9		
			330	30	1.3	20	20 <sup>3)</sup>	○	-	-	-	1.8	2.4	8		
			336	36	1.3	20	20 <sup>3)</sup>	○	-	-	-	1.8	2.4	7		
			340	40	1.3	20	20 <sup>3)</sup>	○	-	-	-	1.2	1.8	7		
			344	44	1.3	20	20 <sup>3)</sup>	○	-	-	-	1.2	1.8	6		
			348	48	1.3	20	20 <sup>3)</sup>	○	-	-	-	1.2	1.8	6		

Note: 1) See calculation method, caution and suggested standard on page 11.

2) Lowest measured value; contact to contact or contact to shell.

3) For a given AWG, the diameter of some stranded conductor designs is larger than the solder cup diameter.

Make sure that the maximum conductor diameter is smaller than øC on page 9 (for solder), and page 10 (for crimp).

● Standard, typically 0-6 weeks delivery for quantities of 250 or less.

○ Non-standard product, contact LEMO USA, typically 6-12 weeks delivery for quantities of 250 or less.

Non-standard product is defined as any product which contains one or more components which are not standard.

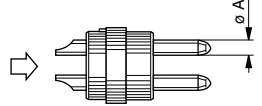
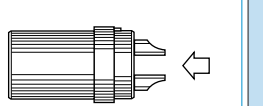
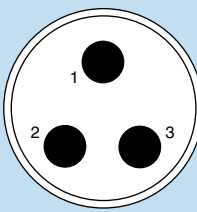
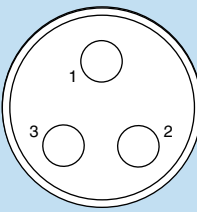
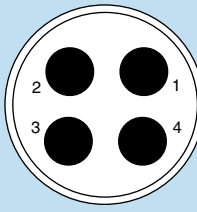
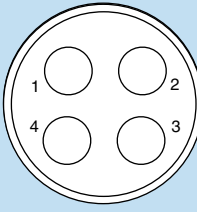
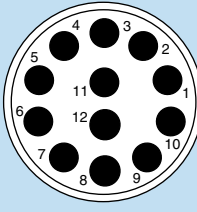
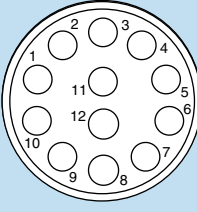
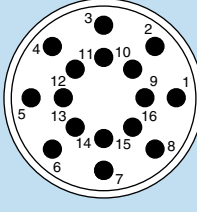
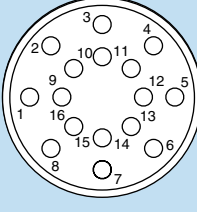
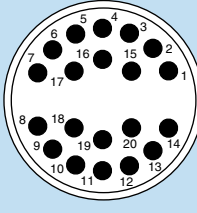
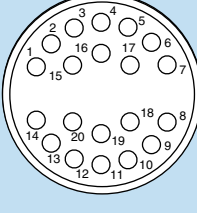

## Multicontact

	 Male solder contacts	 Female solder contacts	Reference	Number of contacts	ø A (mm)	Solder		Contact type availability				Test voltage (kV rms) <sup>1) 2)</sup>	Test voltage (kV dc) <sup>1) 2)</sup>	Rated current (A) <sup>1)</sup>
						AWG max. (solid)	AWG max. (stranded)	Solder	Crimp	Printed circuit (straight)	Printed circuit (elbow)			
<b>6E</b>			303	3	6.0	-	8	○	-	-	-	3.0	4.2	50
			304	4	8.0	-	4	○	-	-	-	3.0	4.2	60
			312	12	5.0	-	8	○	-	-	-	2.1	3.0	22
			316	16	3.0	10	12	○	-	-	-	1.5	2.1	14
			320	20	3.0	10	12	○	-	-	-	1.5	2.1	14

**Note:** 1) See calculation method, caution and suggested standard on page 11.  
 2) Lowest measured value; contact to contact or contact to shell.

● Standard, typically 0-6 weeks delivery for quantities of 250 or less.  
 ○ Non-standard product, contact LEMO USA, typically 6-12 weeks delivery for quantities of 250 or less.  
 Non-standard product is defined as any product which contains one or more components which are not standard.

## Multicontact

	Male solder contacts	Female solder contacts	Reference	Number of contacts	ø A (mm)	Solder		Contact type availability				Test voltage (kV rms) <sup>1) 2)</sup>	Test voltage (kV dc) <sup>1) 2)</sup>	Rated current (A) <sup>1)</sup>
						AWG max. (solid)	AWG max. (stranded)	Solder	Crimp	Printed circuit (straight)	Printed circuit (elbow)			
<b>6E</b>			324	24	3.0	10	12	○	-	-	-	1.2	1.8	12
			330	30	2.0	14	16	○	-	-	-	2.1	3.0	10
			332	32	2.0	14	16	○	-	-	-	1.5	2.1	10
			336	30 6	1.3 5.0	20 -	20 <sup>3)</sup> 8	○	-	-	-	1.5 1.5	2.1 2.1	4 22
			340	40	2.0	14	16	○	-	-	-	1.5	2.1	8

Note: 1) See calculation method, caution and suggested standard on page 11.

2) Lowest measured value; contact to contact or contact to shell.

3) For a given AWG, the diameter of some stranded conductor designs is larger than the solder cup diameter. Make sure that the maximum conductor diameter is smaller than øC on page 9 (for solder), and page 10 (for crimp).

# Multicontact

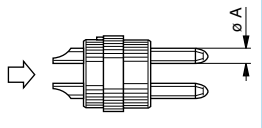
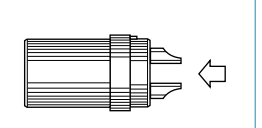
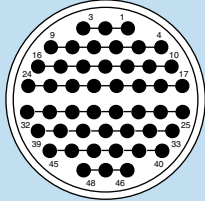
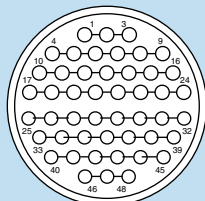
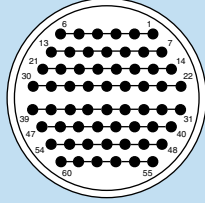
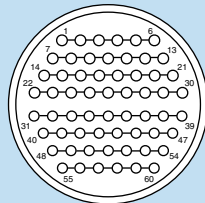
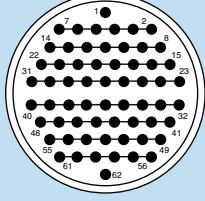
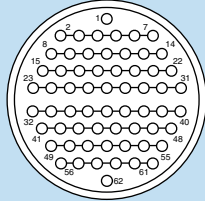
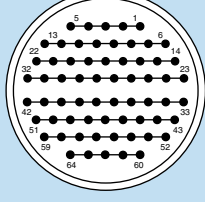
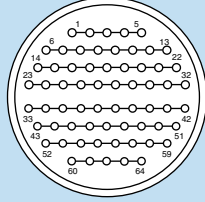
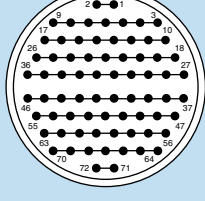
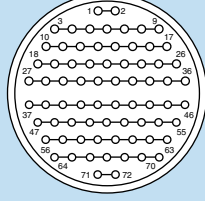
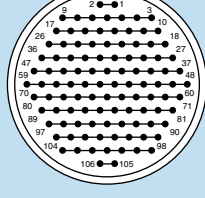
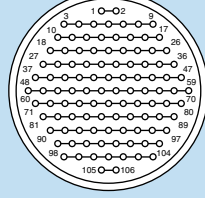
	 Male solder contacts		 Female solder contacts		Reference	Number of contacts	ø A (mm)	Solder		Contact type availability				Test voltage (kV rms) <sup>1) 2)</sup>	Test voltage (kV dc) <sup>1) 2)</sup>	Rated current (A) <sup>1)</sup>
	AWG max. (solid)	AWG max. (stranded)	Solder	Crimp				Printed circuit (straight)	Printed circuit (elbow)							
<b>6E</b>			348	48	2.0	14	16	○	-	-	-	1.5	2.1	7		
			360	60	1.6	16	18	○	-	-	-	1.5	2.1	5		
			362	62	1.6	16	18	○	-	-	-	1.5	2.1	5		
			364	64	1.3	20	20 <sup>3)</sup>	○	-	-	-	1.2	1.8	4		
			372	72	1.3	20	20 <sup>3)</sup>	○	-	-	-	1.2	1.8	4		
			106	106	0.9	22	22 <sup>3)</sup>	○	-	-	-	0.8	1.2	2		

Note: 1) See calculation method, caution and suggested standard on page 11.

2) Lowest measured value; contact to contact or contact to shell.

3) For a given AWG, the diameter of some stranded conductor designs is larger than the solder cup diameter.











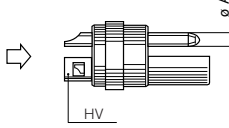
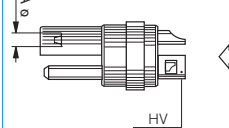

































Make sure that the maximum conductor diameter is smaller than øC on page 9 (for solder), and page 10 (for crimp).

● Standard, typically 0-6 weeks delivery for quantities of 250 or less.

○ Non-standard product, contact LEMO USA, typically 6-12 weeks delivery for quantities of 250 or less.

Non-standard product is defined as any product which contains one or more components which are not standard.

## Mixed Contacts (High Voltage + Low Voltage)











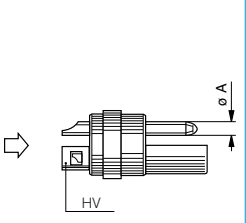
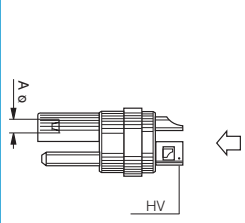
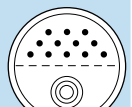
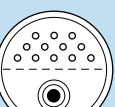
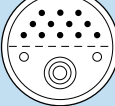
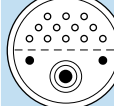
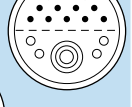
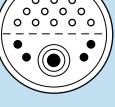
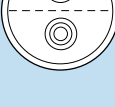
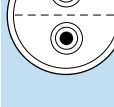

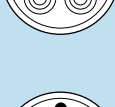
		High voltage						Low voltage									
		Number of contacts	Contact $\phi$ A (mm)	AWG max. (solder)	Dielectric $\phi$ max. (mm)	Test voltage AC	Test voltage DC	Rated current (A) <sup>1)</sup>	Number of contacts	Contact $\phi$ A (mm)	AWG max. (Stranded/ Solder)	Solder	Test Voltage AC	Test Voltage DC	Rated current (A) <sup>4)</sup>		
 Male solder contacts		 Female solder contacts		Reference													
<b>2E</b>			702	1	1.3	20 <sup>1)</sup>	1.3	6300	9000	6	2	2.0	16	○	1500	2100	18
	<b>3E</b>			702	1	1.3	20 <sup>1)</sup>	1.3	6300	9000	6	2	2.0	16	○	1500	2100
			703	1	1.3	20 <sup>1)</sup>	1.3	6300	9000	6	2	1.3	20 <sup>1)</sup>	○	2100	3000	14
			704	1	1.3	20 <sup>1)</sup>	1.3	6300	9000	6	4	1.3	20 <sup>1)</sup>	○	1050	1500	10
			705	1	1.3	20 <sup>1)</sup>	1.3	6300	9000	6	5	1.3	20 <sup>1)</sup>	○	1050	1500	9
			706	1	1.3	20 <sup>1)</sup>	1.3	6300	9000	6	6	1.3	20 <sup>1)</sup>	○	1050	1500	8
			707	1	1.3	20 <sup>1)</sup>	1.3	6300	9000	6	7	1.3	20 <sup>1)</sup>	○	1050	1500	8
			708	1	1.3	20 <sup>1)</sup>	1.3	6300	9000	6	4 4	1.3 0.9	20 <sup>1)</sup> 22 <sup>1)</sup>	○	1050	1500	6 8
			709	1	1.3	20 <sup>1)</sup>	1.3	6300	9000	6	9	0.9	22 <sup>1)</sup>	○	750	1200	6
			711	1	1.3	20 <sup>1)</sup>	1.3	6300	9000	6	11	0.9	22 <sup>1)</sup>	○	750	1200	6
			432	2	1.3	20 <sup>1)</sup>	1.3	6300	9000	6	-	-	-	-	-	-	-
			732	2	1.3	20 <sup>1)</sup>	1.3	6300	9000	6	2	1.3	20 <sup>1)</sup>	○	2100	3000	14
			734	2	1.3	20 <sup>1)</sup>	1.3	6300	9000	6	4	1.3	20 <sup>1)</sup>	○	2100	3000	10
<b>4E</b>				702	1	2.0	16	2.0	6300	9000	8	2	3.0	12	○	2100	3000
			703	1	2.0	16	2.0	6300	9000	8	3	2.0	16	○	2100	3000	16
			704	1	2.0	16	2.0	6300	9000	8	4	1.3	20 <sup>1)</sup>	○	2700	3900	13
			705	1	2.0	16	2.0	6300	9000	8	5	1.3	20 <sup>1)</sup>	○	2100	3000	11
			706	1	2.0	16	2.0	6300	9000	8	6	1.3	20 <sup>1)</sup>	○	2100	3000	9
			707	1	2.0	16	2.0	6300	9000	8	7	1.3	20 <sup>1)</sup>	○	2100	3000	9
			708	1	2.0	16	2.0	6300	9000	8	8	1.3	20 <sup>1)</sup>	○	2100	3000	9
			709	1	2.0	16	2.0	6300	9000	8	9	0.9	22 <sup>1)</sup>	○	2100	3000	7
			710	1	2.0	16	2.0	6300	9000	8	10	0.9	22 <sup>1)</sup>	○	2100	3000	7

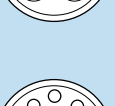
● Standard, typically 0-6 weeks delivery for quantities of 250 or less.

○ Non-standard product, contact LEMO USA, typically 6-12 weeks delivery for quantities of 250 or less.

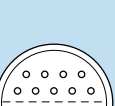
Non-standard product is defined as any product which contains one or more components which are not standard.

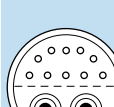
## Mixed Contacts (High Voltage + Low Voltage)

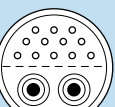
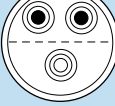
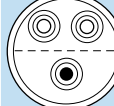
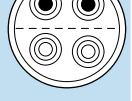
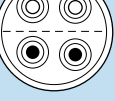
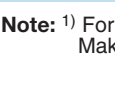
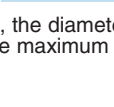
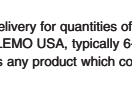
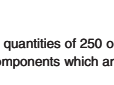
	 Male solder contacts	 Female solder contacts	Reference	High voltage						Low voltage							
				Number of contacts	Contact $\phi$ A (mm)	AWG max. (solder)	Dielectric $\phi$ max. (mm)	Test voltage AC	Test voltage DC	Rated current (A) <sup>1)</sup>	Number of contacts	Contact $\phi$ A (mm)	AWG max. (Stranded/ Solder)	Solder	Test Voltage AC	Test Voltage DC	Rated current (A) <sup>1)</sup>
<b>4E</b>			712	1	2.0	16	2.0	6300	9000	8	12	0.9	22 <sup>1)</sup>	○	2100	3000	7
			714	1	2.0	16	2.0	6300	9000	8	14	0.9	22 <sup>1)</sup>	○	2100	3000	7
			716	1	2.0	16	2.0	6300	9000	8	16	0.9	22 <sup>1)</sup>	○	1500	2100	6
			442	2	2.0	16	1.3	10500	15000	8	-	-	-	-	-	-	-
			732	2	2.0	16	2.0	6300	9000	8	2	3.0	12	○	2100	3000	22
			733	2	2.0	16	2.0	6300	9000	-	3	2.0	16	○	2700	3900	16
			734	2	2.0	16	2.0	6300	9000	-	4	1.3	20 <sup>1)</sup>	○	2700	3900	13
			735	2	2.0	16	2.0	6300	9000	-	5	1.3	20 <sup>1)</sup>	○	2100	3000	11
			736	2	2.0	16	2.0	6300	9000	-	6	1.3	20 <sup>1)</sup>	○	2100	3000	9
			737	2	2.0	16	2.0	6300	9000	-	7	1.3	20 <sup>1)</sup>	○	2100	3000	9
			739	2	2.0	16	2.0	6300	9000	-	9	0.9	22 <sup>1)</sup>	○	2100	3000	7
			740	2	2.0	16	2.0	6300	9000	-	10	0.9	22 <sup>1)</sup>	○	2100	3000	7
			742	2	2.0	16	2.0	6300	9000	-	12	0.9	22 <sup>1)</sup>	○	2100	3000	7
			433	3	2.0	16	2.0	6300	9000	-	-	-	-	-	-	-	-
			434	4	2.0	16	2.0	6300	9000	-	-	-	-	-	-	-	-

**Note:** 1) For a given AWG, the diameter of some stranded conductor designs is larger than the solder cup diameter. Make sure that the maximum conductor diameter is smaller than  $\phi C$  on page 9 (for solder), and page 10 (for crimp).

● Standard, typically 0-6 weeks delivery for quantities of 250 or less.  
 ○ Non-standard product, contact LEMO USA, typically 6-12 weeks delivery for quantities of 250 or less.  
 Non-standard product is defined as any product which contains one or more components which are not standard.

## Mixed Contacts (High Voltage + Low Voltage)

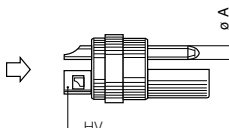
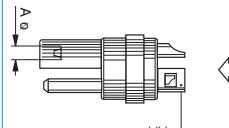
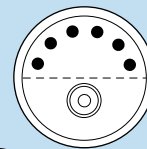
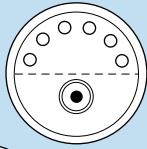
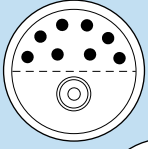
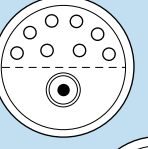
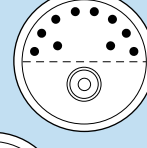
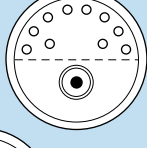
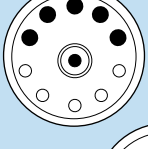
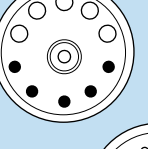
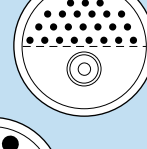
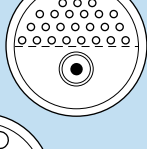
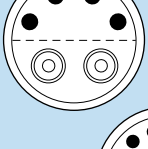
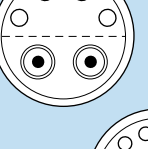
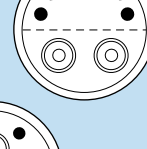
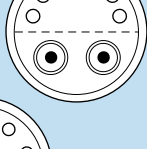
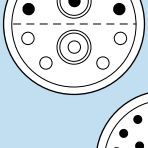
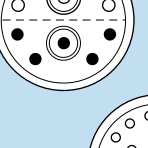
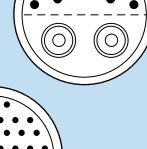
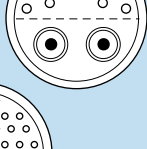
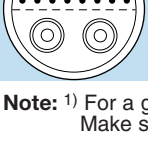
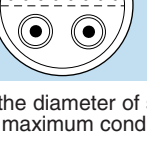
	 Male solder contacts	 Female solder contacts	Reference	High voltage						Low voltage							
				Number of contacts	Contact $\phi$ A (mm)	AWG max. (solder)	Dielectric $\phi$ max. (mm)	Test voltage AC	Test voltage DC	Rated current (A) <sup>1)</sup>	Number of contacts	Contact $\phi$ A (mm)	AWG max. (Stranded/ Solder)	Solder	Test Voltage AC	Test Voltage DC	Rated current (A) <sup>4)</sup>
<b>5E</b>			706	1	2.0	16	2.0	10500	15000	-	6	2.0	16	○	2100	3000	18
			708	1	2.0	16	2.0	10500	15000	-	8	2.0	16	○	1200	1800	15
			710	1	2.0	16	2.0	10500	15000	-	10	1.6	18	○	1200	1800	11
			730	1	2.0	16	2.0	21000	3000	-	10	2.0	16	○	1200	1800	15
			724	1	2.0	16	2.0	10500	15000	-	24	1.3	20 <sup>1)</sup>	○	1200	1800	6
			734	2	2.0	16	2.0	10500	15000	-	4	3.0	12	○	2100	3000	22
			736	2	2.0	16	2.0	10500	15000	-	6	2.0	16	○	2100	3000	18
			738	2	2.0	16	2.0	10500	15000	-	8	2.0	16	○	2100	3000	15
			740	2	2.0	16	2.0	10500	15000	-	10	1.6	18	○	1800	2400	11
			754	2	2.0	16	2.0	10500	15000	-	24	1.3	20 <sup>1)</sup>	○	1200	1800	6











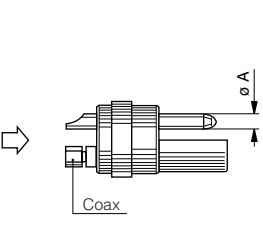
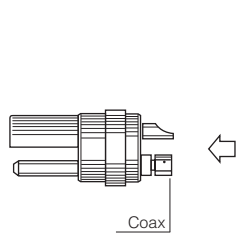





**Note:** 1) For a given AWG, the diameter of some stranded conductor designs is larger than the solder cup diameter. Make sure that the maximum conductor diameter is smaller than  $\phi$ C on page 9 (for solder), and page 10 (for crimp).

## Mixed Contacts (High Voltage + Low Voltage)

	Male solder contacts	Female solder contacts	Reference	High voltage						Low voltage							
				Number of contacts	Contact $\phi$ A (mm)	AWG max. (solder)	Dielectric $\phi$ max. (mm)	Test voltage AC	Test voltage DC	Rated current (A) <sup>1)</sup>	Number of contacts	Contact $\phi$ A (mm)	AWG max. (Stranded/ Solder)	Solder	Test Voltage AC	Test Voltage DC	Rated current (A) <sup>4)</sup>
<b>5E</b>			764	3	2.0	16	2.0	10500	15000	-	4	2.0	16	○	1200	1800	18
			782	4	2.0	16	2.0	10500	15000	-	2	2.0	16	○	1200	1800	18
			442	2	2.0	16	2.0	10500	15000	-	-	-	-	-	-	-	-
			443	3	2.0	16	2.0	10500	15000	-	-	-	-	-	-	-	-
			444	4	2.0	16	2.0	10500	15000	-	-	-	-	-	-	-	-
			438	8	2.0	16	2.0	10500	15000	-	-	-	-	-	-	-	-

● Standard, typically 0-6 weeks delivery for quantities of 250 or less.  
 ○ Non-standard product, contact LEMO USA, typically 6-12 weeks delivery for quantities of 250 or less.  
 Non-standard product is defined as any product which contains one or more components which are not standard.

## Mixed Contacts (Coaxial + Low Voltage)

		Coax							Low voltage							
		Number of contacts	Contact type <sup>1)</sup>	Impedance (ohms)	Cable Group	Test voltage AC	Test voltage DC	Rated current (A) <sup>1)</sup>	Number of contacts	Contact ø A (mm)	AWG max. (Stranded/Solder)	Solder contact availability	Test voltage AC	Test voltage DC	Rated current (A) <sup>4)</sup>	
 <p>Male solder contacts</p>		 <p>Female solder contacts</p>		Reference												
3E		801	1	A1	50	1,2,3	2100	3000	4	1	1.3	20 <sup>1)</sup>	○	2700	3900	14
		802	1	A1	50	1,2,3	2100	3000	4	2	1.3	20 <sup>1)</sup>	○	1200	1800	14
		803	1	A1	50	1,2,3	2100	3000	4	3	1.3	20 <sup>1)</sup>	○	2700	3900	14
		804	1	A1	50	1,2,3	2100	3000	4	4	1.3	20 <sup>1)</sup>	○	1200	1800	10
		805	1	A1	50	1,2,3	2100	3000	4	5	0.9	22 <sup>1)</sup>	○	1800	2400	8
		804	1	A1	50	1,2,3	2100	3000	4	6	1.3	20 <sup>1)</sup>	○	750	1200	8
		807	1	A1	50	1,2,3	2100	3000	4	7	0.9	22 <sup>1)</sup>	○	750	2100	7
4E		802	1	A1	50	1,2,3	2100	3000	4	2	3.0	12	○	2100	3000	22
		803	1	A1	50	1,2,3	2100	3000	4	3	2.0	16	○	2100	3000	16
		804	1	A1	50	1,2,3	2100	3000	4	4	1.3	20 <sup>1)</sup>	○	2700	3900	13
		805	1	A1	50	1,2,3	2100	3000	4	5	1.3	20 <sup>1)</sup>	○	2100	3000	11
		806	1	A1	50	1,2,3	2100	3000	4	6	1.3	20 <sup>1)</sup>	○	2100	3000	9
		807	1	A1	50	1,2,3	2100	3000	4	7	1.3	20 <sup>1)</sup>	○	2100	3000	8
		809	1	A1	50	1,2,3	2100	3000	4	9	0.9	22 <sup>1)</sup>	○	2100	3000	7
		810	1	A1	50	1,2,3	2100	3000	4	10	0.9	22 <sup>1)</sup>	○	2100	3000	7

**Note:** <sup>1)</sup> For a given AWG, the diameter of some stranded conductor designs is larger than the solder cup diameter. Make sure that the maximum conductor diameter is smaller than øC on page 9 (for solder), and page 10 (for crimp).



### Mixed Contacts (Coaxial + Low Voltage)

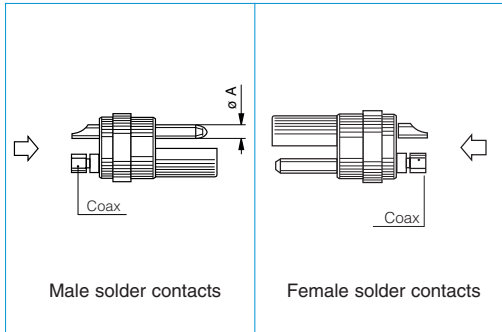

	Reference	Coax						Low voltage							
		Number of contacts	Contact type <sup>1)</sup>	Impedance (ohms)	Cable Group	Test voltage AC	Test voltage DC	Rated current (A) <sup>1)</sup>	Number of contacts	Contact ø A (mm)	AWG max. (Stranded/Solder)	Solder contact availability	Test voltage AC	Test voltage DC	Rated current (A) <sup>4)</sup>
<b>4E</b>	812	1	A1	50	1,2,3	2100	3000	4	12	0.9	22 <sup>1)</sup>	○	2100	3000	4
	202	2	A1	50	1,2,3	2100	3000	4	-	-	-	-	-	-	
	832	2	A1	50	1,2,3	2100	3000	4	2	1.3	20 <sup>1)</sup>	○	2100	3000	13
	834	2	A1	50	1,2,3	2100	3000	4	4	1.3	20 <sup>1)</sup>	○	2100	3000	13
	836	2	A1	50	1,2,3	2100	3000	4	6	0.9	22 <sup>1)</sup>	○	1800	2400	7
	838	2	A1	50	1,2,3	2100	3000	4	8	0.9	22 <sup>1)</sup>	○	1800	2400	7
	842	2	A1	50	1,2,3	2100	3000	4	12	0.9	22 <sup>1)</sup>	○	1800	2400	7
<b>5E</b>	804	1	A0	50	1,2,6	2100	2400	6	4	3.0	12	○	1800	2400	7
	810	1	A1	50	1,2,3	2100	3000	4	10	1.6	18	○	1800	2400	11
	232	2	A0	50	1,2,6	3000	4200	6	-	-	-	-	-	-	
	282	2	A1	50	6	3000	4200	12	-	-	-	-	-	-	
	292	2	A	75	3,5,7	2400	3300	10	-	-	-	-	-	-	
	832	2	A0	50	1,2,6	3000	4200	6	2	2.0	16	○	2100	3000	18

● Standard, typically 0-6 weeks delivery for quantities of 250 or less.  
 ○ Non-standard product, contact LEMO USA, typically 6-12 weeks delivery for quantities of 250 or less.  
 Non-standard product is defined as any product which contains one or more components which are not standard.

## Mixed Contacts (Coaxial + Low Voltage)

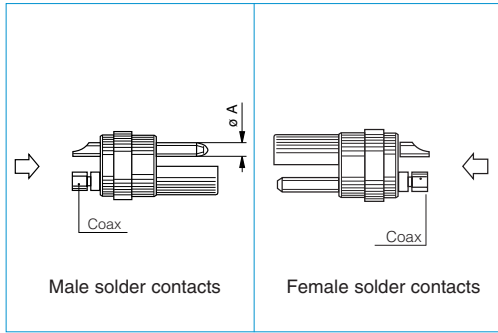

Reference	Coax						Low voltage							
	Number of contacts	Contact type <sup>1)</sup>	Impedance (ohms)	Cable Group	Test voltage AC	Test voltage DC	Rated current (A) <sup>1)</sup>	Number of contacts	Contact ø A (mm)	AWG max. (Stranded/Solder)	Solder contact availability	Test voltage AC	Test voltage DC	Rated current (A) <sup>1)</sup>
834	2	A0	50	1,2,6	3000	4200	6	4	2.0	16	○	2100	3000	18
838	2	A0	50	1,2,6	3000	4200	6	8	1.6	18	○	1700	2400	12
842	2	A0	50	1,2,6	2100	3000	6	12	1.3	20 <sup>1)</sup>	○	1700	2400	9
846	2	A0	50	1,2,6	3000	4200	6	16	1.3	20 <sup>1)</sup>	○	750	1200	8
846	2	A	75	3,5,7	2400	3300	10	16	1.3	20 <sup>1)</sup>	○	750	1200	8
850	2	A0	50	1,2,6	3000	4200	6	20	1.3	20 <sup>1)</sup>	○	750	1200	7
854	2	A0	50	1,2,6	3000	4200	6	24	1.3	20 <sup>1)</sup>	○	750	1200	6
234	4	A1	50	1,2,3	2100	3000	4	-	-	-	-	-	-	-
876	4	A1	50	1,2,3	2100	3000	4	6	1.3	20 <sup>1)</sup>	○	750	1200	6

**Note:** 1) For a given AWG, the diameter of some stranded conductor designs is larger than the solder cup diameter. Make sure that the maximum conductor diameter is smaller than øC on page 9 (for solder), and page 10 (for crimp).

### Mixed Contacts (Coaxial + Low Voltage)

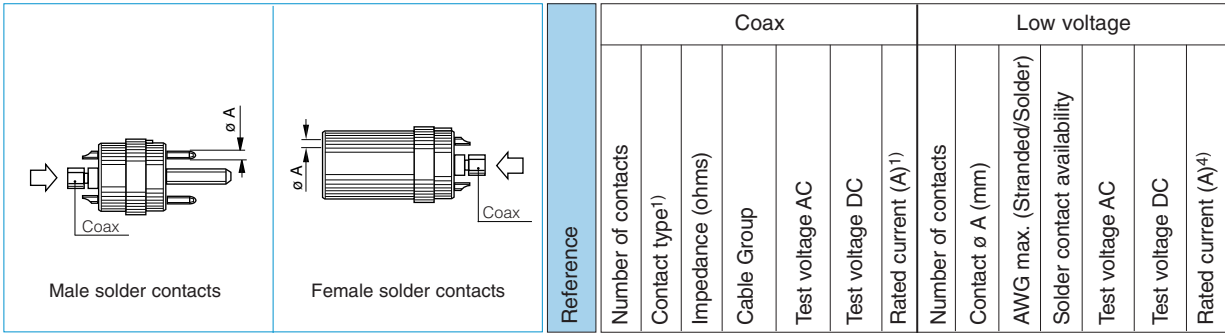

Reference	Coax							Low voltage						
	Number of contacts	Contact type <sup>1)</sup>	Impedance (ohms)	Cable Group	Test voltage AC	Test voltage DC	Rated current (A) <sup>1)</sup>	Number of contacts	Contact ø A (mm)	AWG max. (Stranded/Solder)	Solder contact availability	Test voltage AC	Test voltage DC	Rated current (A) <sup>4)</sup>
857	2	A	50	3,5,7	2400	3300	10	33	1.3	20 <sup>1)</sup>	○	1200	1800	4
880	4	A1	50	3,5,7	2100	3000	4	20	1.3	20 <sup>1)</sup>	○	1200	1800	4
882	4	A	75	3,5,7	2400	3300	10	26	0.9	22 <sup>1)</sup>	○	750	1200	2
888	1 4	A3 A1	50	9 1,2,3	3000 2100	4200 3000	26 4	7	2.0	16	○	1000	2100	10
899	8	A1	50	1,2,3	2100	3000	5	20	1.6	18	○	1500	2100	7

**Note:** 1) For a given AWG, the diameter of some stranded conductor designs is larger than the solder cup diameter. Make sure that the maximum conductor diameter is smaller than øC on page 9 (for solder), and page 10 (for crimp).

● Standard, typically 0-6 weeks delivery for quantities of 250 or less.  
 ○ Non-standard product, contact LEMO USA, typically 6-12 weeks delivery for quantities of 250 or less.  
 Non-standard product is defined as any product which contains one or more components which are not standard.

## • Technical Information

### Example of high voltage contact construction for mixed high voltage and multi high voltage connectors

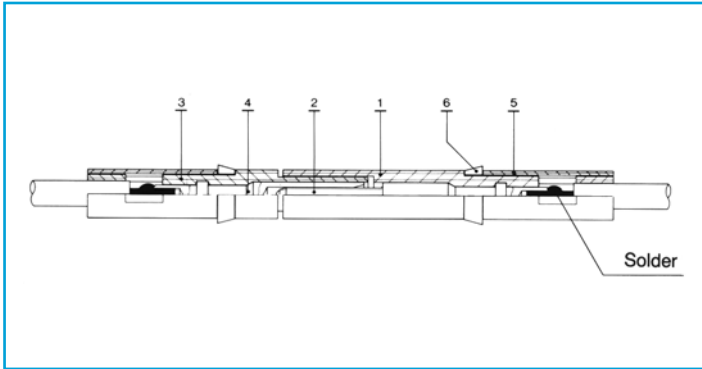

The high voltage contact is permanently fixed into the inserts. The conductor is secured by solder.

Component	Material	Surface Treatment		
		Cu	Ni	Au
1 Insert	PTFE (ASTM D 1457-83)			
2 Male Contact	Brass (UNS C 385)	0.5	3	1.5
3 Insert	PTFE (ASTM D 1457-83)			
4 Female Contact	Bronze (UNS C 544)	0.5	3	2.5
5 Insert Tube	PTFE (ASTM D 1457-83)			
6 Clips	Brass (UNS C 385)	0.5	3	

### Example of coaxial contact construction for mixed coax and multi coax connectors

#### Coaxial type A0, A, A1 and type A3

The coaxial of this type is permanently fixed into the insert. The conductor is secured by solder and the shield by crimping.

The high voltage contact is permanently fixed into the inserts. The conductor is secured by solder and the shield by crimping.

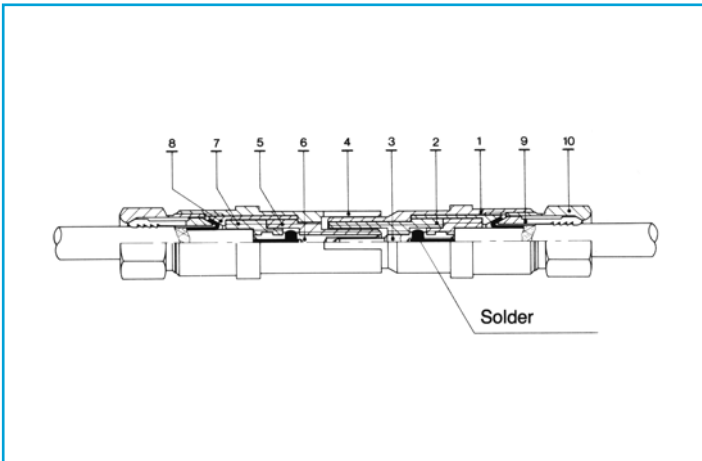

Component	Material	Surface Treatment		
		Cu	Ni	Au
1 Male Sleeve	Brass (UNS C 385)	0.5	3	1.5
2 Insert	PTFE (UNS D 1457-83)			
3 Male Contact	Brass (UNS C 385)	0.5	3	1.5
4 Female Sleeve	Bronze (UNS C 544)	0.5	3	2.0
5 Insert	PTFE (UNS D 1457-83)			
6 Female Contact	Bronze (UNS C 544)	0.5	3	2.5
7 Insulating Sleeve	PTFE (UNS D 1457-83)			
8 Grounding Sleeve	Brass (UNS C 385)	0.5	3	
9 Collet	Brass (UNS C 187)	0.5	3	
10 Ferrule	Brass (UNS C 385)	0.5	3	

## Technical characteristics of coax contacts

The coaxial part is permanently fixed in the main insert. The inner conductor of the cable is soldered to the contact while the outer conductor is clamped by the collet.

Characteristics	Unit	Coax Type A		Coax Type A0	Coax Type A1	Coax Type A3
Impedance	$\Omega$	50	75	50	50	50
Test voltage at 50 Hz	AC	1800	2300	300	800	3000
Rated current	A	12	7	7	5	15
Insulating resistance	$\Omega$	$>10_{12}$	$>10_{12}$	$>10_{12}$	$>10_{12}$	$>10_{12}$
Contact resistance	m $\Omega$	2.0	2.9	4.5	3.8	2.0
Shell to shell resistance	m $\Omega$	1.8	1.8	1.0	3.0	1.0
VSWR (f = GHz)		1.01 +0.146f	1.01 +0.019f	1.06 +0.1f	1.01 +0.127f	1.06 +0.5f

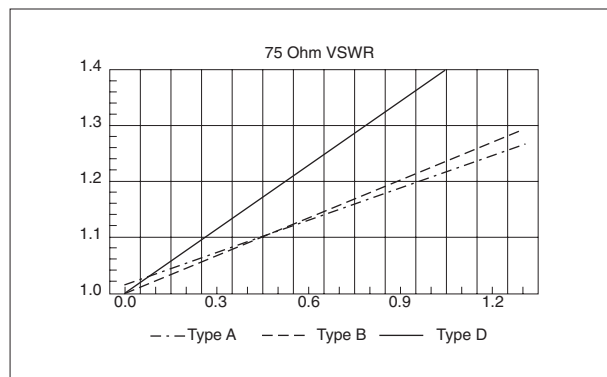
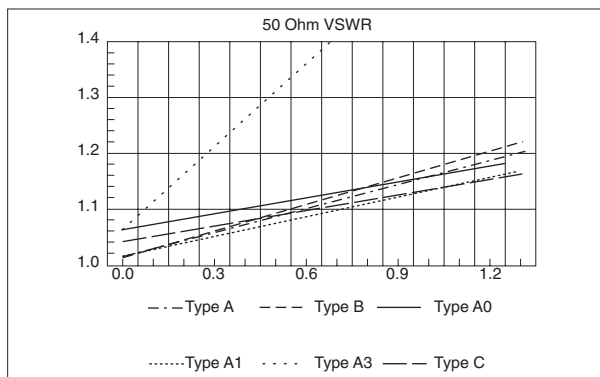

## Recommended coaxial and triaxial cable for mixed coax and multicoax connectors

Type	Group 1)							Type	Group 1)						
	1	2	3	5	6	7	1		2	3	5	6	7		
RG.58 C/U				■				RG.188 A/U		■					
RG.59 B/U					■			RG.196 A/U	■						
RG.115 A/U						■		RG.213 /U							■
RG.122 /U			■					RG.223 /U					■		
RG.142 B/U				■				RG.302 /U				■			
RG.165 /U						■		RG.316 /U		■					
RG.174 A/U		■						RG.400 /U				■			
RG.178 B/U	■							CCE.99.281.505 LEMO			■				

1) The cable group number corresponding to the chosen cable must be written in the variant position of the part number.

## ● Housings

Ref.	Material	Surface treatment		Note
		Outer shell and collet nut	Latch sleeve and grounding crown	
C	Brass <sup>1)</sup>	chrome	nickel	■
D	Brass	gold-plated	nickel	□
N	Brass	nickel	nickel	□
K	Brass	black chrome	nickel	■
S	Stainless steel	without treatment	nickel-plated brass	□
T	Stainless steel	without treatment	stainless steel	□
U	Stainless steel <sup>2)</sup>	without treatment	stainless steel	□
L	Aluminium alloy <sup>3)</sup>	anodized	nickel-plated brass	□
B	POM black <sup>4)</sup>	without treatment	nickel-plated brass	■
H	PPS/brass <sup>5)</sup>	without treat./nickel	nickel	■
G	PEEK <sup>4)</sup>	without treatment	nickel-plated brass	■
P	PSU <sup>6)</sup>	without treatment	nickel-plated brass	■
R	PPSU <sup>7)</sup>	without treatment	nickel-plated brass	■

### Note:

- 1) In the E series the latch sleeve is chrome-plated.
- 2) The other metallic components are in stainless steel.
- 3) The «variant» position of the reference is used to specify the anodized color. See color chart on page 81.
- 4) Only available for FFP, ERN and PCP models of the S series.
- 5) For S series EPL and EXP elbow (90°) receptacles for printed circuit.
- 6) Available only for the FFL model of the S series. See colors in «variant» position.
- 7) Available only for the FFL model of the S series. Detailed characteristics of these materials are presented on page 5.

■ First choice alternative □ Special order alternative

## ● Insulators

Ref.	Material or form	Note
L	PEEK	■
T	PTFE <sup>1)</sup>	■
T	FEP <sup>2)</sup>	□

Ref.	Material or form	Note
V	PI <sup>2)</sup>	□
N	PA6.6 <sup>3)</sup>	■

### Note:

- 1) Only for single contact types.
- 2) Only for multicontact types.
- 3) Material for 5E and 6E series multicontact inserts. Detailed characteristics of these materials are presented on page 7.

■ First choice alternative □ Special order alternative

## ● Contacts

### Contacts for plugs, free or fixed receptacles

Ref.	Contact type
A	Male solder
C	Male crimp <sup>1) 4)</sup>
L	Female solder
M	Female crimp <sup>2) 4)</sup>
N	Female printed circuit (straight)
V	Female printed circuit (elbow)

Multicontact connectors are fitted with hermaphroditic inserts including male and female contacts. However, by convention, the letter indicating the contact type in the part number composition will be the male contact (reference A) for plugs and female contact (reference L) for receptacles.

In case of an odd number of contacts, the letter of reference corresponds to the one with the larger number of contacts. For example, a 309 type connector with contact (reference A) will include 5 male and 4 female contacts.

### Contact configuration for RMA, RAD and SWH fixed couplers

**A Male - Female**

**L Female - Male**

**A** Multicontact (odd) **L**

**A** Multicontact (even) **A<sup>1)</sup>**

**M Female - Female**

**A** Multicontact (odd) **A<sup>1)</sup>**

**A** Multicontact (even) **A<sup>1)</sup>**

### Use of plugs for mating with RAD, RMA and SWH couplers

#### Single contact type:

Reference M For coupling two identical plugs fitted with male contact (contact reference A).

Reference L For coupling a plug fitted with male contacts (contact reference A) at the flange end for RAD and SWH and an inverted plug fitted with female contacts (contact reference L) at the other end.

Reference A For the inverted version of code L.

#### Multicontact type:

Reference L For coupling a standard plug (contact reference A) at the flange end for RAD and SWH and an inverted plug (contact reference as indicated in the above table) at the other end.

Reference M For coupling two standard plugs (contact type A).  
Only available for RAD and RMA models.

**Note:** <sup>1)</sup> This connector combination does not allow for contact numbering. One of the plugs has to be cable mounted in a way to ensure correct signal continuity.

### Contacts for couplers and plug with receptacle

Ref.	Contact type	single contact	multicontact
A	Male - Female	○	—
L	Female - Male	○	●
M	Female - Female	●	○
F	Female - Female - Male <sup>3)</sup>	●	●

For RAD and SWH fixed couplers, the first contact type mentioned is always the one at the flange end. Contact configuration and receptacles to be used for a connection are explained on the following page.

#### Note:

<sup>1)</sup> For the FFS model of the 00 series and FFA or FFL models of the S series.

<sup>2)</sup> For the PSS model of the 00 series and PCA or PSA models of the S series.

<sup>3)</sup> For the FTA model of the S series.

<sup>4)</sup> For conductor range that can fit with crimp contacts consult page 9.

Connectors can be configured « inverted » i.e. plugs equipped with female contacts (reference L), receptacles with male contacts (reference A). This solution is particularly useful when plugs are mated to a coupler and it is essential to respect contact alignment (see next page).

# Collets

## C and K type collets

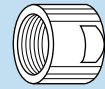
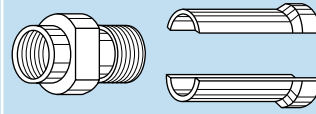

	Reference		Collet		Cable ø		Part number of the collet system <sup>1)</sup>	Part number of the oversize collet and of the split center-pieces <sup>2)</sup>	Part number of the collet nut <sup>2)</sup>	Availability
	Type	ø	ø A	ø B	max.	min.				
0E	C	10	1.6	–	1.2	1.0	FFA.0E.710.CNS	–	FFA.0E.130.LC	○
	C	15	1.6	–	1.5	1.3	FFA.0E.715.CNS	–	FFA.0E.130.LC	○
	C	20	2.1	–	2.0	1.6	FFA.0E.720.CNS	–	FFA.0E.130.LC	○
	C	25	3.1	–	2.5	2.1	FFA.0E.725.CNS	–	FFA.0E.130.LC	○
	C	30	3.1	–	3.0	2.6	FFA.0E.730.CNS	–	FFA.0E.130.LC	○
	C	35	4.2	4.2	3.5	3.1	FFA.0E.735.CNS	–	FFA.0E.130.LC	○
	C	40	4.2	4.2	4.0	3.6	FFA.0E.740.CNS	–	FFA.0E.130.LC	○
	C	45	5.2	5.2	4.5	4.1	FFA.0E.745.CNS	–	FFA.0E.131.LC	●
	C	50	5.2	5.2	5.0	4.6	FFA.0E.750.CNS	–	FFA.0E.131.LC	●
1E	C	15	1.6	–	1.5	1.3	FFA.1E.715.CNS	–	FFA.1E.130.LC	○
	C	20	2.2	–	2.0	1.6	FFA.1E.720.CNS	–	FFA.1E.130.LC	○
	C	25	3.2	–	2.5	2.1	FFA.1E.725.CNS	–	FFA.1E.130.LC	●
	C	30	3.2	–	3.0	2.6	FFA.1E.730.CNS	–	FFA.1E.130.LC	○
	C	35	4.2	–	3.5	3.1	FFA.1E.735.CNS	–	FFA.1E.130.LC	○
	C	40	4.2	–	4.0	3.6	FFA.1E.740.CNS	–	FFA.1E.130.LC	○
	C	45	5.2	–	4.5	4.1	FFA.1E.745.CNS	–	FFA.1E.130.LC	●
	C	50	5.2	–	5.0	4.6	FFA.1E.750.CNS	–	FFA.1E.130.LC	●
	C	55	6.2	6.2	5.5	5.1	FFA.1E.755.CNS	–	FFA.1E.130.LC	●
	C	60	6.2	6.2	6.0	5.6	FFA.1E.760.CNS	–	FFA.1E.130.LC	●
	C	65	7.2	6.7	6.5	6.1	FFA.1E.765.CNS	–	FFA.1E.130.LC	●
	K	70	7.2	–	7.0	6.6	FFA.2E.770.CNS	FFA.1E.137.LCN	FFA.2E.130.LC	○
	K	75	8.2	8.2	7.5	7.1	FFA.2E.775.CNS	FFA.1E.137.LCN	FFA.2E.130.LC	○
	K	80	8.2	8.2	8.0	7.6	FFA.2E.780.CNS	FFA.1E.137.LCN	FFA.2E.130.LC	○
K	85	9.2	8.6	8.5	8.1	FFA.2E.785.CNS	FFA.1E.137.LCN	FFA.2E.130.LC	○	
2E	C	15	2.2	–	1.5	1.3	FFA.2E.715.CNS	–	FFA.2E.130.LC	○
	C	20	2.2	–	2.0	1.6	FFA.2E.720.CNS	–	FFA.2E.130.LC	○
	C	25	3.2	–	2.5	2.1	FFA.2E.725.CNS	–	FFA.2E.130.LC	○
	C	30	3.2	–	3.0	2.6	FFA.2E.730.CNS	–	FFA.2E.130.LC	○
	C	35	4.2	–	3.5	3.1	FFA.2E.735.CNS	–	FFA.2E.130.LC	○
	C	40	4.2	–	4.0	3.6	FFA.2E.740.CNS	–	FFA.2E.130.LC	○
	C	45	5.2	–	4.5	4.1	FFA.2E.745.CNS	–	FFA.2E.130.LC	○
	C	50	5.2	–	5.0	4.6	FFA.2E.750.CNS	–	FFA.2E.130.LC	○
	C	55	6.2	–	5.5	5.1	FFA.2E.755.CNS	–	FFA.2E.130.LC	○
	C	60	6.2	–	6.0	5.6	FFA.2E.760.CNS	–	FFA.2E.130.LC	○
	C	65	7.2	–	6.5	6.1	FFA.2E.765.CNS	–	FFA.2E.130.LC	○
	C	70	7.2	–	7.0	6.6	FFA.2E.770.CNS	–	FFA.2E.130.LC	○
	C	75	8.2	8.2	7.5	7.1	FFA.2E.775.CNS	–	FFA.2E.130.LC	○
	C	80	8.2	8.2	8.0	7.6	FFA.2E.780.CNS	–	FFA.2E.130.LC	○
	C	85	9.2	8.6	8.5	8.1	FFA.2E.785.CNS	–	FFA.2E.130.LC	○
	K	90	9.2	–	9.0	8.6	FFA.3E.790.CNS	FFA.2E.137.LCN	FFA.3E.130.LC	○
	K	95	10.2	10.2	9.5	9.1	FFA.3E.795.CNS	FFA.2E.137.LCN	FFA.3E.130.LC	○
	K	10	10.2	10.2	10.0	9.6	FFA.3E.710.CNS	FFA.2E.137.LCN	FFA.3E.130.LC	○
K	11	11.2	10.6	11.0	10.1	FFA.3E.711.CNS	FFA.2E.137.LCN	FFA.3E.130.LC	○	

**Note:**

<sup>1)</sup> For ordering the collet system separately.

<sup>2)</sup> For ordering a K type collet separately, the oversize collet and the corresponding collet nut should also be ordered.

All dimensions are in millimeters.

● Standard, typically 0-6 weeks delivery for quantities of 250 or less.

○ Non-standard product, contact LEMO USA, typically 6-12 weeks delivery for quantities of 250 or less.

Non-standard product is defined as any product which contains one or more components which are not standard.



### C and K type collets

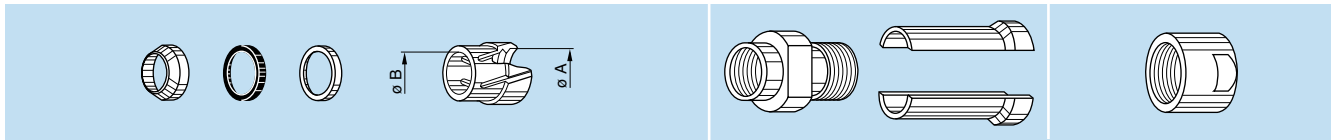

	Reference		Collet		Cable $\phi$		Part number of the collet system <sup>1)</sup>	Part number of the oversize collet and of the split center-pieces <sup>2)</sup>	Part number of the collet nut <sup>2)</sup>	Availability
	Type	$\phi$	$\phi A$	$\phi B$	max.	min.				
<b>3E</b>	C	30	3.2	–	3.0	2.6	FFA.3E.730.CNS	–	FFA.3E.130.LC	○
	C	35	4.2	–	3.5	3.1	FFA.3E.735.CNS	–	FFA.3E.130.LC	○
	C	40	4.2	–	4.0	3.6	FFA.3E.740.CNS	–	FFA.3E.130.LC	○
	C	45	5.2	–	4.5	4.1	FFA.3E.745.CNS	–	FFA.3E.130.LC	○
	C	50	5.2	–	5.0	4.6	FFA.3E.750.CNS	–	FFA.3E.130.LC	○
	C	55	6.2	–	5.5	5.1	FFA.3E.755.CNS	–	FFA.3E.130.LC	○
	C	60	6.2	–	6.0	5.6	FFA.3E.760.CNS	–	FFA.3E.130.LC	○
	C	65	7.2	–	6.5	6.1	FFA.3E.765.CNS	–	FFA.3E.130.LC	○
	C	70	7.2	–	7.0	6.6	FFA.3E.770.CNS	–	FFA.3E.130.LC	○
	C	75	8.2	–	7.5	7.1	FFA.3E.775.CNS	–	FFA.3E.130.LC	○
	C	80	8.2	–	8.0	7.6	FFA.3E.780.CNS	–	FFA.3E.130.LC	○
	C	85	9.2	–	8.5	8.1	FFA.3E.785.CNS	–	FFA.3E.130.LC	○
	C	90	9.2	–	9.0	8.6	FFA.3E.790.CNS	–	FFA.3E.130.LC	○
	C	95	10.2	10.2	9.5	9.1	FFA.3E.795.CNS	–	FFA.3E.130.LC	○
	C	10	10.2	10.2	10.0	9.6	FFA.3E.710.CNS	–	FFA.3E.130.LC	○
	C	11	11.2	11.2	10.6	10.1	FFA.3E.711.CNS	–	FFA.3E.130.LC	○
	K	11	12.3	–	12.0	10.6	FFA.4E.711.CNS	FFA.3E.137.LCN	FFA.4E.130.LC	○
	K	12	13.8	13.8	12.8	12.1	FFA.4E.712.CNS	FFA.3E.137.LCN	FFA.4E.130.LC	○
K	13	13.8	13.8	13.5	12.9	FFA.4E.713.CNS	FFA.3E.137.LCN	FFA.4E.130.LC	○	
K	14	15.3	15.3	14.0	13.6	FFA.4E.714.CNS	FFA.3E.137.LCN	FFA.4E.130.LC	○	
K	15	15.3	15.3	15.0	14.1	FFA.4E.715.CNS	FFA.3E.137.LCN	FFA.4E.130.LC	○	
<b>4E</b>	C	50	6.3	–	5.0	4.6	FFA.4E.750.CNS	–	FFA.4E.130.LC	○
	C	55	6.3	–	5.5	5.1	FFA.4E.755.CNS	–	FFA.4E.130.LC	○
	C	60	6.3	–	6.0	5.6	FFA.4E.760.CNS	–	FFA.4E.130.LC	○
	C	65	7.3	–	6.5	6.1	FFA.4E.765.CNS	–	FFA.4E.130.LC	○
	C	70	7.3	–	7.0	6.6	FFA.4E.770.CNS	–	FFA.4E.130.LC	○
	C	75	8.3	–	7.5	7.1	FFA.4E.775.CNS	–	FFA.4E.130.LC	○
	C	80	8.3	–	8.0	7.6	FFA.4E.780.CNS	–	FFA.4E.130.LC	○
	C	85	9.3	–	8.5	8.1	FFA.4E.785.CNS	–	FFA.4E.130.LC	○
	C	90	9.3	–	9.0	8.6	FFA.4E.790.CNS	–	FFA.4E.130.LC	○
	C	95	10.8	–	9.5	9.1	FFA.4E.795.CNS	–	FFA.4E.130.LC	○
	C	10	10.8	–	10.5	9.6	FFA.4E.710.CNS	–	FFA.4E.130.LC	○
	C	11	12.3	–	12.0	10.6	FFA.4E.711.CNS	–	FFA.4E.130.LC	○
	C	12	13.8	13.8	12.8	12.1	FFA.4E.712.CNS	–	FFA.4E.130.LC	○
	C	13	13.8	13.8	13.5	12.9	FFA.4E.713.CNS	–	FFA.4E.130.LC	○
	C	14	15.3	15.3	14.0	13.6	FFA.4E.714.CNS	–	FFA.4E.130.LC	○
	C	15	15.3	15.3	15.0	14.1	FFA.4E.715.CNS	–	FFA.4E.130.LC	○
	K	16	17.8	–	16.5	15.6	FFA.4K.716.CNS	FFA.4E.137.LCN <sup>3)</sup>	FFA.4K.136.LC	○
	K	17	17.8	–	17.5	16.6	FFA.4K.717.CNS	FFA.4E.137.LCN	FFA.4K.136.LC	○
	K	18	19.8	–	18.5	17.6	FFA.4K.718.CNS	FFA.4E.137.LCN	FFA.4K.136.LC	○
	K	19	19.8	–	19.5	18.6	FFA.4K.719.CNS	FFA.4E.137.LCN	FFA.4K.136.LC	○
	K	20	21.8	–	20.5	19.6	FFA.4K.720.CNS	FFA.4E.137.LCN	FFA.4K.136.LC	○
	K	21	21.8	–	21.5	20.6	FFA.4K.721.CNS	FFA.4E.137.LCN	FFA.4K.136.LC	○
	K	22	23.8	23.8	22.5	21.6	FFA.4K.722.CNS	FFA.4E.137.LCN	FFA.4K.136.LC	○
K	23	23.8	23.8	23.5	22.6	FFA.4K.723.CNS	FFA.4E.137.LCN	FFA.4K.136.LC	○	

**Note:**

- 1) For ordering the collet system separately.
- 2) For ordering a K type collet separately, the oversize collet and the corresponding collet nut should also be ordered.
- 3) In 4E series, the center-piece is made of one piece.

All dimensions are in millimeters.

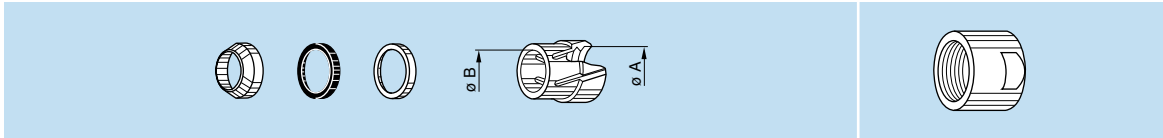
**C type collets**

	Reference		Collet		Cable $\varnothing$		Part number of the collet system <sup>1)</sup>	Part number of the collet nut	Availability
	Type	$\varnothing$	$\varnothing A$	$\varnothing B$	max.	min.			
<b>5E</b>	C	10	11.8	–	10.5	9.6	FFA.5K.710.CNS	FFA.5K.130.LC	○
	C	11	11.8	–	11.5	10.6	FFA.5K.711.CNS	FFA.5K.130.LC	○
	C	12	13.8	–	12.5	11.6	FFA.5K.712.CNS	FFA.5K.130.LC	○
	C	13	13.8	–	13.5	12.6	FFA.5K.713.CNS	FFA.5K.130.LC	○
	C	14	15.8	–	14.5	13.6	FFA.5K.714.CNS	FFA.5K.130.LC	○
	C	15	15.8	–	15.5	14.6	FFA.5K.715.CNS	FFA.5K.130.LC	○
	C	16	17.8	–	16.5	15.6	FFA.5K.716.CNS	FFA.5K.130.LC	○
	C	17	17.8	–	17.5	16.6	FFA.5K.717.CNS	FFA.5K.130.LC	○
	C	18	19.8	–	18.5	17.6	FFA.5K.718.CNS	FFA.5K.130.LC	○
	C	19	19.8	–	19.5	18.6	FFA.5K.719.CNS	FFA.5K.130.LC	○
	C	20	21.8	–	20.5	19.6	FFA.5K.720.CNS	FFA.5K.130.LC	○
	C	21	21.8	–	21.5	20.6	FFA.5K.721.CNS	FFA.5K.130.LC	○
	C	22	23.8	23.8	22.5	21.6	FFA.5K.722.CNS	FFA.5K.130.LC	○
C	23	23.8	23.8	23.5	22.6	FFA.5K.723.CNS	FFA.5K.130.LC	○	
<b>6E</b>	C	14	14.2	–	14.0	13.0	FFA.6E.714.CNS	FGG.6E.130.LC	○
	C	15	15.2	–	15.0	14.1	FFA.6E.715.CNS	FGG.6E.131.LC	○
	C	16	15.7	–	15.5	14.6	FFA.6E.716.CNS	PKG.6E.131.LC	○
	C	17	16.7	–	16.5	15.6	FFA.6E.717.CNS	PKG.6E.132.LC	○
	C	18	18.2	–	18.0	17.1	FFA.6E.718.CNS	FGG.6E.132.LC	○
	C	21	23.2	–	21.5	20.6	FFA.6E.721.CNS	FGG.6E.133.LC	○
	C	22	23.2	–	22.0	21.1	FFA.6E.722.CNS	PKG.6E.133.LC	○
	C	23	23.2	–	23.0	22.1	FFA.6E.723.CNS	FGG.6E.134.LC	○
	C	27	27.2	–	27.0	26.1	FFA.6E.727.CNS	FGG.6E.135.LC	○
	C	30	30.2	–	30.0	29.5	FFA.6E.730.CNS	FGG.6E.136.LC	○

**Note:** <sup>1)</sup> For ordering the collet system separately.

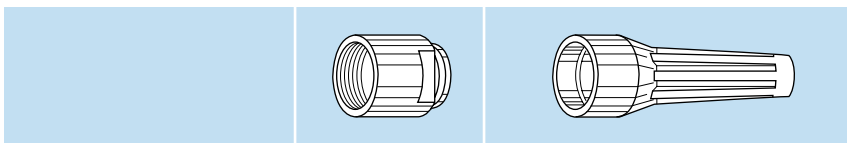
**Bend relief nut and bend relief**

	Reference		Part number of the collet nut	Bend relief to be used <sup>1)</sup>
	Type	$\varnothing$		
<b>0E</b>	C	10 to 50	FFM.0E.130.LC	GMA.0B.●●●●●●
<b>1E</b>	C	15 to 65	FFM.1E.130.LC	GMA.1B.●●●●●●
	K	70 to 85	FFM.2E.130.LC	GMA.2B.●●●●●●
<b>2E</b>	C	15 to 85	FFM.2E.130.LC	GMA.2B.●●●●●●
	K	90 to 11	FFM.3E.130.LC	GMA.3B.●●●●●●
<b>3E</b>	C	30 to 10	FFM.3E.130.LC	GMA.3B.●●●●●●
	K	11 to 15	FFM.4E.130.LC	GMA.4B.●●●●●●
<b>4E</b>	C	50 to 15	FFM.4E.130.LC	GMA.4B.●●●●●●

**Note:** <sup>1)</sup> The bend relief is to be ordered separately (see pages 91 and 92). All dimensions are in millimeters.

## Anodized color

The «variant» position of the reference is used to specify the anodized color according to the table below.

Part number for connector with standard collet nut

Ref.	Anodized color	Ref.	Anodized color
A	blue	R	red
J	yellow	T	natural
N	black	V	green

Part number for connector with bend relief backnut

Ref.	Anodized color
L	black
X	natural

**Note:** Other anodizing colors are available for connectors with bend relief backnut. Please consult us.



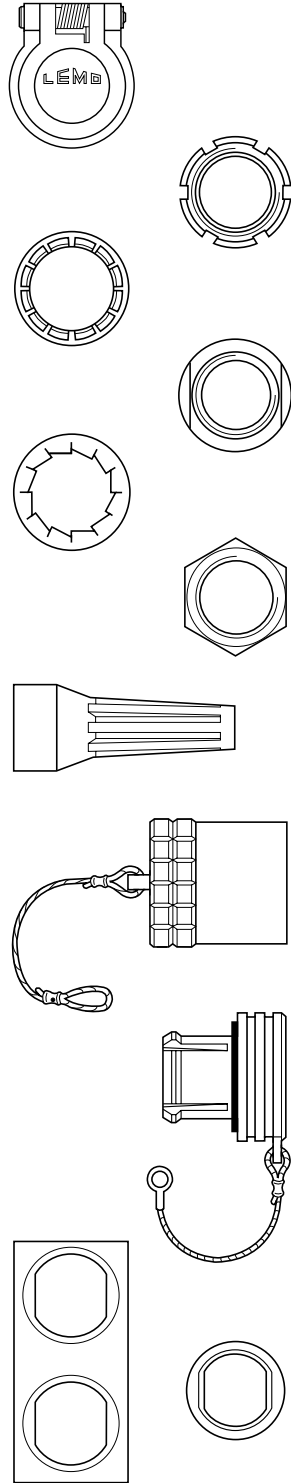

• **Accessories**

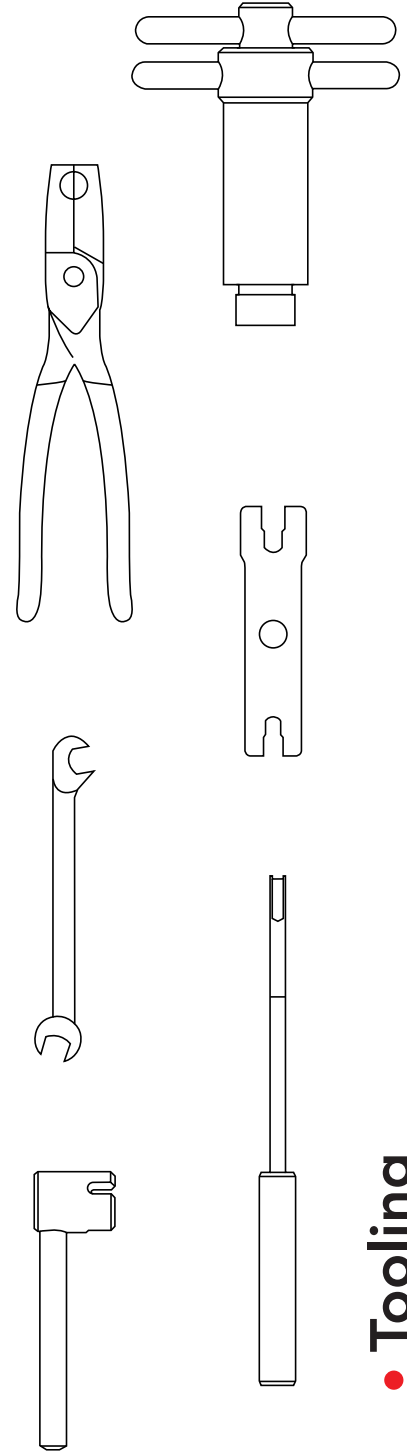

• **Tooling**

## ● Accessories

### FGG-EGG Insulators for crimp contacts

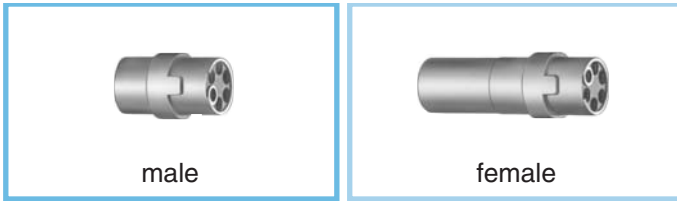

	Type	Insulator part number			
		Male contact	Avail-ability	Female contact	Avail-ability
<b>0K</b>	302	FGG.0B.302.YL	○	EGG.0B.402.YL	○
	303	FGG.0B.303.YL	○	EGG.0B.403.YL	○
	304	FGG.0B.304.YL	○	EGG.0B.404.YL	○
	305	FGG.0B.305.YL	○	EGG.0B.405.YL	○
	306	FGG.0B.306.YL	○	-	
	307	FGG.0B.307.YL	○	-	
	309	FGG.0B.309.YL	○	-	
<b>1K</b>	302	FGG.1B.302.YL	○	EGG.1B.402.YL	○
	303	FGG.1B.303.YL	○	EGG.1B.403.YL	○
	304	FGG.1B.304.YL	○	EGG.1B.404.YL	○
	305	FGG.1B.305.YL	○	EGG.1B.405.YL	○
	306	FGG.1B.306.YL	○	EGG.1B.406.YL	○
	307	FGG.1B.307.YL	○	EGG.1B.407.YL	○
	308	FGG.1B.308.YL	○	EGG.1B.408.YL	○
	310	FGG.1B.310.YL	○	-	
	314	FGG.1B.314.YL	○	-	
<b>2K</b>	302	FGG.2B.302.YL	○	EGG.2B.402.YL	○
	303	FGG.2B.303.YL	○	EGG.2B.403.YL	○
	304	FGG.2B.304.YL	○	EGG.2B.404.YL	○
	305	FGG.2B.305.YL	○	EGG.2B.405.YL	○
	306	FGG.2B.306.YL	○	EGG.2B.406.YL	○
	307	FGG.2B.307.YL	○	EGG.2B.407.YL	○
	308	FGG.2B.308.YL	○	EGG.2B.408.YL	○
	310	FGG.2B.310.YL	○	EGG.2B.410.YL	○
	312	FGG.2B.312.YL	○	EGG.2B.412.YL	○
	314	FGG.2B.314.YL	○	EGG.2B.414.YL	○
	316	FGG.2B.316.YL	○	EGG.2B.416.YL	○
	318	FGG.2B.318.YL	○	EGG.2B.418.YL	○
	319	FGG.2B.319.YL	○	EGG.2B.419.YL	○
	326	FGG.2B.326.YL	○	-	
332	FGG.2B.332.YL	○	-		
<b>3K</b>	302	FGG.3B.302.YL	○	EGG.3B.402.YL	○
	303	FGG.3B.303.YL	○	EGG.3B.403.YL	○
	304	FGG.3B.304.YL	○	EGG.3B.404.YL	○
	305	FGG.3B.305.YL	○	EGG.3B.405.YL	○
	306	FGG.3B.306.YL	○	EGG.3B.406.YL	○
	307	FGG.3B.307.YL	○	EGG.3B.407.YL	○

	Type	Insulator part number			
		Male contact	Avail-ability	Female contact	Avail-ability
<b>3K</b>	308	FGG.3B.308.YL	○	EGG.3B.408.YL	○
	309	FGG.3B.309.ML	○	EGG.3B.409.ML	○
	310	FGG.3B.310.YL	○	EGG.3B.410.YL	○
	312	FGG.3B.312.YL	○	EGG.3B.412.YL	○
	314	FGG.3B.314.YL	○	EGG.3B.414.YL	○
	316	FGG.3B.316.YL	○	EGG.3B.416.YL	○
	318	FGG.3B.318.YL	○	EGG.3B.418.YL	○
	320	FGG.3B.320.YL	○	EGG.3B.420.YL	○
	322	FGG.3B.322.YL	○	EGG.3B.422.YL	○
	324	FGG.3B.324.YL	○	EGG.3B.424.YL	○
	326	FGG.3B.326.YL	○	EGG.3B.426.YL	○
	330	FGG.3B.330.YL	○	EGG.3B.430.YL	○
	<b>4K</b>	304	FGG.4B.304.YL	○	EGG.4B.404.YL
306		FGG.4B.306.YL	○	EGG.4B.406.YL	○
307		FGG.4B.307.YL	○	EGG.4B.407.YL	○
310		FGG.4B.310.YL	○	EGG.4B.410.YL	○
312		FGG.4B.312.YL	○	EGG.4B.412.YL	○
316		FGG.4B.316.YL	○	EGG.4B.416.YL	○
320		FGG.4B.320.YL	○	EGG.4B.420.YL	○
324		FGG.4B.324.YL	○	EGG.4B.424.YL	○
330		FGG.4B.330.YL	○	EGG.4B.430.YL	○
340		FGG.4B.340.YL	○	EGG.4B.440.YL	○
<b>5K</b>	304	FGG.5B.304.ML	○	EGG.5B.404.ML	○
	310	FGG.5B.310.YL	○	EGG.5B.410.YL	○
	314	FGG.5B.314.YL	○	EGG.5B.414.YL	○
	316	FGG.5B.316.YL	○	EGG.5B.416.YL	○
	320	FGG.5B.320.YL	○	EGG.5B.420.YL	○
	330	FGG.5B.330.YL	○	EGG.5B.430.YL	○
	340	FGG.5B.340.YL	○	EGG.5B.440.YL	○
	348	FGG.5B.348.YL	○	EGG.5B.448.YL	○
	350	FGG.5B.350.ML	○	EGG.5B.450.ML	○
	354	FGG.5B.354.YL	○	EGG.5B.454.YL	○
	364	FGG.5B.364.YL	○	EGG.5B.464.YL	○

**Note:** Each insulator can be used both for crimp contacts of normal shape (fig. 1) or with reduced solder cups (fig. 2) as shown on page 85 to 87.

### FGG-EGG Crimp contacts

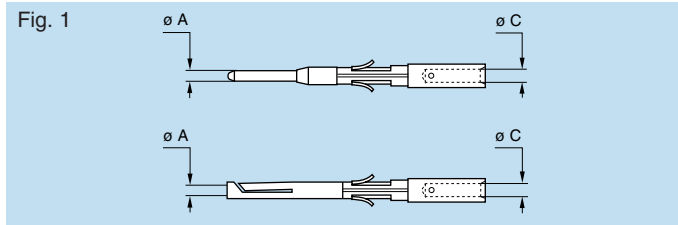

**Note:**  
See next page for additional style

Standard Crimp Barrel

	Types	ø A (mm)	ø C (mm)	Contact part number			
				Male	Avail-ability	Female	Avail-ability
<b>0K</b>	302/303	0.9	1.10	FGG.0B.560.ZZC	●	EGG.0B.660.ZZM	●
	304/305	0.7	0.80	FGG.0B.555.ZZC	●	EGG.0B.655.ZZM	●
	306/307/309	0.5	0.45	FGG.0B.554.ZZC	○	EGG.0B.654.ZZM	○
<b>1K</b>	302/303	1.3	1.40	FGG.1B.565.ZZC	●	EGG.1B.665.ZZM	○
	304/305	0.9	1.10	FGG.1B.560.ZZC	●	EGG.1B.660.ZZM	●
	306/307/308	0.7	0.80	FGG.1B.555.ZZC	●	EGG.1B.655.ZZM	●
	310/314/316	-	-	-	-	-	-
	702/731	1.3	1.40	FGG.1B.565.ZZC	●	EGG.1B.665.ZZM	○
<b>2K</b>	302	2.0	2.40	FGG.2B.575.ZZC	●	EGG.2B.675.ZZM	●
	303	1.6	1.90	FGG.2B.570.ZZC	●	EGG.2B.670.ZZM	●
	304/305	1.3	1.40	FGG.2B.565.ZZC	●	EGG.2B.665.ZZM	●
	306/307	1.3	1.40	FGG.2B.565.ZZC	●	EGG.2B.665.ZZM	●
	308/310	0.9	1.10	FGG.2B.560.ZZC	●	EGG.2B.660.ZZM	●
	312/314/316	0.7	0.80	FGG.2B.555.ZZC	●	EGG.2B.655.ZZM	●
	318/319	0.7	0.80	FGG.2B.555.ZZC	●	EGG.2B.655.ZZM	●
	326/332	-	-	-	-	-	-
	704	0.7	0.80	FGG.2B.555.ZZC	●	EGG.2B.655.ZZM	●
	706	1.3	1.40	FGG.2B.565.ZZC	●	EGG.2B.665.ZZM	●
	708	0.9	1.10	FGG.2B.560.ZZC	●	EGG.2B.660.ZZM	●
	802	0.9	1.10	FGG.2B.560.ZZC	●	EGG.2B.660.ZZM	●
	804/806/810	0.7	0.80	FGG.2B.555.ZZC	●	EGG.2B.655.ZZM	●
<b>3K</b>	302	3.0	2.90	FGG.3B.580.ZZC	○	EGG.3B.680.ZZM	○
	303/304/309	2.0	2.40	FGG.3B.575.ZZC	●	EGG.3B.675.ZZM	●
	305/306/307	1.6	1.90	FGG.3B.570.ZZC	●	EGG.3B.670.ZZM	●
	308/309/310	1.3	1.40	FGG.3B.565.ZZC	●	EGG.3B.665.ZZM	●
	312/314	0.9	1.10	FGG.3B.560.ZZC	●	EGG.3B.660.ZZM	●
	316/318	0.9	1.10	FGG.3B.560.ZZC	●	EGG.3B.660.ZZM	●
	320/322/324	0.7	0.80	FGG.3B.555.ZZC	●	EGG.3B.655.ZZM	●
	326/330	0.7	0.80	FGG.3B.555.ZZC	●	EGG.3B.655.ZZM	●
	709	0.7	0.80	FGG.3B.555.ZZC	●	EGG.3B.655.ZZM	●
	712	0.9	1.10	FGG.3B.560.ZZC	●	EGG.3B.660.ZZM	●
	718/740	0.7	0.80	FGG.3B.555.ZZC	●	EGG.3B.655.ZZM	●
	803	0.9	1.10	FGG.3B.560.ZZC	●	EGG.3B.660.ZZM	●
	806/809	0.7	0.80	FGG.3B.555.ZZC	●	EGG.3B.655.ZZM	●
	812	0.9	1.10	FGG.3B.560.ZZC	●	EGG.3B.660.ZZM	●
	813/822	0.7	0.80	FGG.3B.555.ZZC	●	EGG.3B.655.ZZM	●
	844/846	0.9	1.10	FGG.3B.560.ZZC	●	EGG.3B.660.ZZM	●
	850/856	0.7	0.80	FGG.3B.555.ZZC	●	EGG.3B.655.ZZM	●
862	0.9	1.10	FGG.3B.560.ZZC	●	EGG.3B.660.ZZM	●	
<b>4K</b>	304	3.0	2.90	FGG.4B.580.ZZC	○	EGG.4B.680.ZZM	○
	306/307	2.0	2.40	FGG.4B.575.ZZC	○	EGG.4B.675.ZZM	○
	310	1.6	1.90	FGG.4B.570.ZZC	○	EGG.4B.670.ZZM	○
	312	1.3	1.40	FGG.4B.565.ZZC	○	EGG.4B.665.ZZM	○
	316/320	0.9	1.10	FGG.4B.560.ZZC	○	EGG.4B.660.ZZM	○
	324/330	0.9	1.10	FGG.4B.560.ZZC	○	EGG.4B.660.ZZM	○
	340	0.7	0.80	FGG.4B.555.ZZC	○	EGG.4B.655.ZZM	○

● Standard, typically 0-6 weeks delivery for quantities of 250 or less.  
○ Non-standard product, contact LEMO USA, typically 6-12 weeks delivery for quantities of 250 or less.  
Non-standard product is defined as any product which contains one or more components which are not standard.

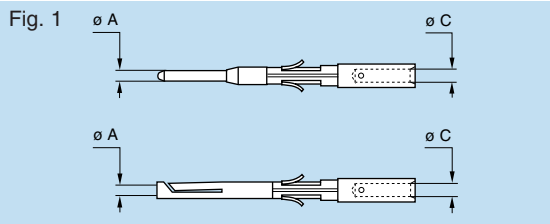

Standard Crimp Barrel

**4K**

340	0.7	0.80	FGG.4B.555.ZZC	○	EGG.4B.655.ZZM	○
745	0.9	1.10	FGG.4B.560.ZZC	○	EGG.4B.660.ZZM	○
802/804/806	0.9	1.10	FGG.4B.560.ZZC	○	EGG.4B.660.ZZM	○
822/824/826	0.9	1.10	FGG.4B.560.ZZC	○	EGG.4B.660.ZZM	○
842/844/852	0.9	1.10	FGG.4B.560.ZZC	○	EGG.4B.660.ZZM	○
856	0.9	1.10	FGG.4B.560.ZZC	○	EGG.4B.660.ZZM	○
858/866/879	0.7	0.80	FGG.4B.555.ZZC	○	EGG.4B.655.ZZM	○
885	0.7	0.80	FGG.4B.555.ZZC	○	EGG.4B.655.ZZM	○

**5K**

304	4.0	4.00	FGG.5B.582.ZZC	○	EGG.5B.682.ZZM	○
310	3.0	2.90	FGG.5B.580.ZZC	○	EGG.5B.680.ZZM	○
314/316	2.0	2.40	FGG.5B.575.ZZC	○	EGG.5B.675.ZZM	○
320	1.6	1.90	FGG.5B.570.ZZC	○	EGG.5B.670.ZZM	○
330/340/348	1.3	1.40	FGG.5B.565.ZZC	○	EGG.5B.665.ZZM	○
350/354/364	0.9	1.10	FGG.5B.560.ZZC	○	EGG.5B.660.ZZM	○
752	1.3	1.40	FGG.5B.565.ZZC	○	EGG.5B.665.ZZM	○
752	1.6	1.90	FGG.5B.570.ZZC	○	EGG.5B.670.ZZM	○
759	0.9	1.10	FGG.5B.560.ZZC	○	EGG.5B.660.ZZM	○
850/856	0.9	1.10	FGG.5B.560.ZZC	○	EGG.5B.660.ZZM	○
857	2.0	2.40	FGG.5B.575.ZZC	○	EGG.5B.675.ZZM	○
857	0.9	1.10	FGG.5B.560.ZZC	○	EGG.5B.660.ZZM	○
864	1.3	1.40	FGG.5B.565.ZZC	○	EGG.5B.665.ZZM	○
870/876/877	0.9	1.10	FGG.5B.560.ZZC	○	EGG.5B.660.ZZM	○
877	2.0	2.40	FGG.5B.575.ZZC	○	EGG.5B.675.ZZM	○
892	0.9	1.10	FGG.5B.560.ZZC	○	EGG.5B.660.ZZM	○
997	1.3	1.40	FGG.5B.565.ZZC	○	EGG.5B.665.ZZM	○

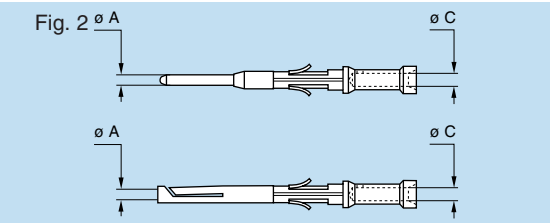

Optional Reduced Crimp Barrel

**0K**

Types	$\varnothing A$ (mm)	$\varnothing C$ (mm)	Contact part number			
			Male	Availability	Female	Availability
302/303	0.9	0.80	FGG.0B.561.ZZC	○	EGG.0B.661.ZZM	○
302/303	0.9	0.45	FGG.0B.562.ZZC	○	EGG.0B.662.ZZM	○
304/305	0.7	0.45	FGG.0B.556.ZZC	○	EGG.0B.656.ZZM	○

**1K**

302/303	1.3	1.10	FGG.1B.566.ZZC	○	EGG.1B.666.ZZM	○
304/305	0.9	0.80	FGG.1B.561.ZZC	○	EGG.1B.661.ZZM	○
304/305	0.9	0.45	FGG.1B.562.ZZC	○	EGG.1B.662.ZZM	○
306/307/308	0.7	0.45	FGG.1B.556.ZZC	○	EGG.1B.656.ZZM	○
702/731	1.3	1.10	FGG.1B.566.ZZC	○	EGG.1B.666.ZZM	○

**2K**

302	2.0	1.90	FGG.2B.576.ZZC	○	EGG.2B.676.ZZM	○
303	1.6	1.40	FGG.2B.571.ZZC	○	EGG.2B.671.ZZM	○
304/305	1.3	1.10	FGG.2B.566.ZZC	○	EGG.2B.666.ZZM	○
306/307	1.3	1.10	FGG.2B.566.ZZC	○	EGG.2B.666.ZZM	○
304/305	1.3	0.80	FGG.2B.567.ZZC	○	EGG.2B.667.ZZM	○
306/307	1.3	0.80	FGG.2B.567.ZZC	○	EGG.2B.667.ZZM	○
308/310	0.9	0.80	FGG.2B.561.ZZC	○	EGG.2B.661.ZZM	○
308/310	0.9	0.45	FGG.2B.562.ZZC	○	EGG.2B.662.ZZM	○
312/314/316	0.7	0.45	FGG.2B.556.ZZC	○	EGG.2B.656.ZZM	○
318/319	0.7	0.45	FGG.2B.556.ZZC	○	EGG.2B.656.ZZM	○
704	0.7	0.45	FGG.2B.556.ZZC	○	EGG.2B.656.ZZM	○
706	1.3	1.10	FGG.2B.566.ZZC	○	EGG.2B.666.ZZM	○
706	1.3	0.80	FGG.2B.567.ZZC	○	EGG.2B.667.ZZM	○
708	0.9	0.80	FGG.2B.561.ZZC	○	EGG.2B.661.ZZM	○
708	0.9	0.45	FGG.2B.562.ZZC	○	EGG.2B.662.ZZM	○
802	0.9	0.80	FGG.2B.561.ZZC	○	EGG.2B.661.ZZM	○
802	0.9	0.45	FGG.2B.562.ZZC	○	EGG.2B.662.ZZM	○
804/806/810	0.7	0.45	FGG.2B.556.ZZC	○	EGG.2B.656.ZZM	○

● Standard, typically 0-6 weeks delivery for quantities of 250 or less.

○ Non-standard product, contact LEMO USA, typically 6-12 weeks delivery for quantities of 250 or less.

Non-standard product is defined as any product which contains one or more components which are not standard.



### FGG-EGG Crimp contacts

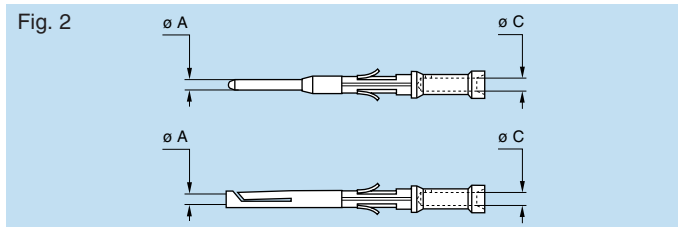

Optional Reduced Crimp Barrel

	Types	ø A (mm)	ø C (mm)	Contact part number			
				Male	Avail-ability	Female	Avail-ability
<b>3K</b>	303/304/309	2.0	1.90	FGG.3B.576.ZZC	○	EGG.3B.676.ZZM	○
	305/306/307	1.6	1.40	FGG.3B.571.ZZC	○	EGG.3B.671.ZZM	○
	308/309/310	1.3	1.10	FGG.3B.566.ZZC	○	EGG.3B.666.ZZM	○
	312/314	0.9	0.80	FGG.3B.561.ZZC	○	EGG.3B.661.ZZM	○
	316/318	0.9	0.80	FGG.3B.561.ZZC	○	EGG.3B.661.ZZM	○
	320/322/324	0.7	0.45	FGG.3B.556.ZZC	○	EGG.3B.656.ZZM	○
	326/330	0.7	0.45	FGG.3B.556.ZZC	○	EGG.3B.656.ZZM	○
	709	0.7	0.45	FGG.3B.556.ZZC	○	EGG.3B.656.ZZM	○
	712	0.9	0.80	FGG.3B.561.ZZC	○	EGG.3B.661.ZZM	○
	718/740	0.7	0.45	FGG.3B.556.ZZC	○	EGG.3B.656.ZZM	○
	803	0.9	0.80	FGG.3B.561.ZZC	○	EGG.3B.661.ZZM	○
	806/809	0.7	0.45	FGG.3B.556.ZZC	○	EGG.3B.656.ZZM	○
	812	0.9	0.80	FGG.3B.561.ZZC	○	EGG.3B.661.ZZM	○
	813/822	0.7	0.45	FGG.3B.556.ZZC	○	EGG.3B.656.ZZM	○
	844/846	0.9	0.80	FGG.3B.561.ZZC	○	EGG.3B.661.ZZM	○
	850/856	0.7	0.45	FGG.3B.556.ZZC	○	EGG.3B.656.ZZM	○
862	0.9	0.80	FGG.3B.561.ZZC	○	EGG.3B.661.ZZM	○	
<b>4K</b>	306/307	2.0	1.90	FGG.4B.576.ZZC	○	EGG.4B.676.ZZM	○
	310	1.6	1.40	FGG.4B.571.ZZC	○	EGG.4B.671.ZZM	○
	312	1.3	1.10	FGG.4B.566.ZZC	○	EGG.4B.666.ZZM	○
	316/320	0.9	0.80	FGG.4B.561.ZZC	○	EGG.4B.661.ZZM	○
	324/330	0.9	0.80	FGG.4B.561.ZZC	○	EGG.4B.661.ZZM	○
	340	0.7	0.45	FGG.4B.556.ZZC	○	EGG.4B.656.ZZM	○
	745	0.9	0.80	FGG.4B.561.ZZC	○	EGG.4B.661.ZZM	○
	802/804/806	0.9	0.80	FGG.4B.561.ZZC	○	EGG.4B.661.ZZM	○
	822/824/826	0.9	0.80	FGG.4B.561.ZZC	○	EGG.4B.661.ZZM	○
	842/844/852	0.9	0.80	FGG.4B.561.ZZC	○	EGG.4B.661.ZZM	○
	856	0.9	0.80	FGG.4B.561.ZZC	○	EGG.4B.661.ZZM	○
	858/866/879	0.7	0.45	FGG.4B.556.ZZC	○	EGG.4B.656.ZZM	○
	885	0.7	0.45	FGG.4B.556.ZZC	○	EGG.4B.656.ZZM	○
<b>5K</b>	314/316	2.0	1.90	FGG.5B.576.ZZC	○	EGG.5B.676.ZZM	○
	320	1.6	1.40	FGG.5B.571.ZZC	○	EGG.5B.671.ZZM	○
	330/340/348	1.3	1.10	FGG.5B.566.ZZC	○	EGG.5B.666.ZZM	○
	350/354/364	0.9	0.80	FGG.5B.561.ZZC	○	EGG.5B.661.ZZM	○
	752	1.3	1.10	FGG.5B.566.ZZC	○	EGG.5B.666.ZZM	○
	752	1.6	1.40	FGG.5B.571.ZZC	○	EGG.5B.671.ZZM	○
	759	0.9	0.80	FGG.5B.561.ZZC	○	EGG.5B.661.ZZM	○
	850/856/857	0.9	0.80	FGG.5B.561.ZZC	○	EGG.5B.661.ZZM	○
	857	2.0	1.90	FGG.5B.576.ZZC	○	EGG.5B.676.ZZM	○
	864	1.3	1.10	FGG.5B.566.ZZC	○	EGG.5B.666.ZZM	○
	870/876/877	0.9	0.80	FGG.5B.561.ZZC	○	EGG.5B.661.ZZM	○
	877	2.0	1.90	FGG.5B.576.ZZC	○	EGG.5B.676.ZZM	○
	892	0.9	0.80	FGG.5B.561.ZZC	○	EGG.5B.661.ZZM	○
	997	1.3	1.10	FGG.5B.566.ZZC	○	EGG.5B.666.ZZM	○

● Standard, typically 0-6 weeks delivery for quantities of 250 or less.  
 ○ Non-standard product, contact LEMO USA, typically 6-12 weeks delivery for quantities of 250 or less.  
 Non-standard product is defined as any product which contains one or more components which are not standard.

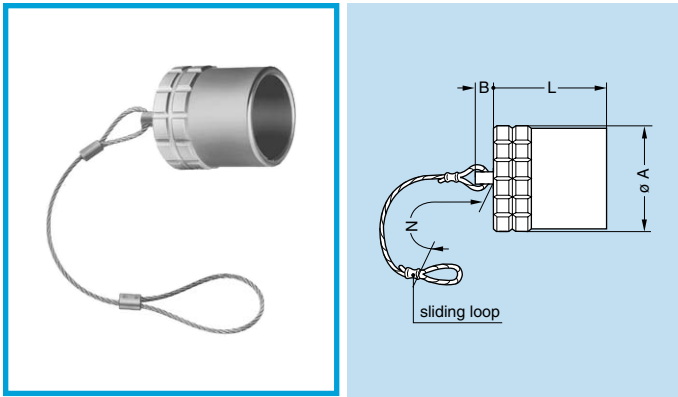

### BFA Plug caps

Part number	Series	Dimensions (mm)				Availability
		A	B	L	N	
BFA.0E.100.NAS	0E	14.0	6	15.0	85	○
BFA.1E.100.NAS	1E	16.0	6	18.0	85	○
BFA.2E.100.NAS	2E	19.5	6	20.0	85	○
BFA.3E.100.NAS	3E	23.0	6	24.0	120	○
BFA.4E.100.NAS	4E	29.0	10	24.5	120	○
BFA.5E.100.NAS	5E	44.0	10	29.0	150	○

**Note:** The last letter «S» of the part number stands for the material of the O-ring (silicone rubber). O-rings made from FPM are also available; if required, replace the letter «S» by «V».

- Body material: Nickel-plated brass (Ni 3µm)
- Lanyard material: Stainless steel
- Crimp ferrule material: Nickel-plated brass + polyolefin
- O-ring material: Silicone rubber or FPM
- Maximum operating temperature: 275° F
- Watertightness: IP68 according to IEC 60529 for E series

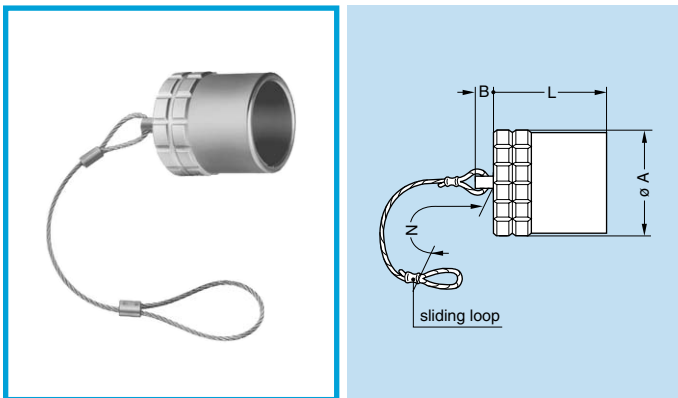

### BFG Plug caps with key (G)

Part number	Series	Dimensions (mm)				Availability
		A	B	L	N	
BFG.0K.100.NAS	0K	14.0	6	15.0	85	○
BFG.1K.100.NAS	1K	16.0	6	18.0	85	○
BFG.2K.100.NAS	2K	19.5	6	20.0	85	○
BFG.3K.100.NAS	3K	23.0	6	24.0	120	○
BFG.4K.100.NAS	4K	29.0	10	24.5	120	○
BFG.5K.100.NAS	5K	44.0	10	29.0	150	○
BFG.6E.100.NAS	6E	54.0	10	34.0	150	○

**Note:** This cap is available only with an alignment key (G). The last letter «S» of the part number stands for the material of the O-ring (silicone rubber). O-rings made from FPM are also available; if required, replace the letter «S» by «V».

- Body material: Nickel-plated brass (Ni 3µm)
- Lanyard material: Stainless steel
- Crimp ferrule material: Nickel-plated brass + polyolefin
- O-ring material: Silicone rubber or FPM
- Maximum operating temperature: 275° F
- Watertightness: IP68 according to IEC 60529 for E and K series

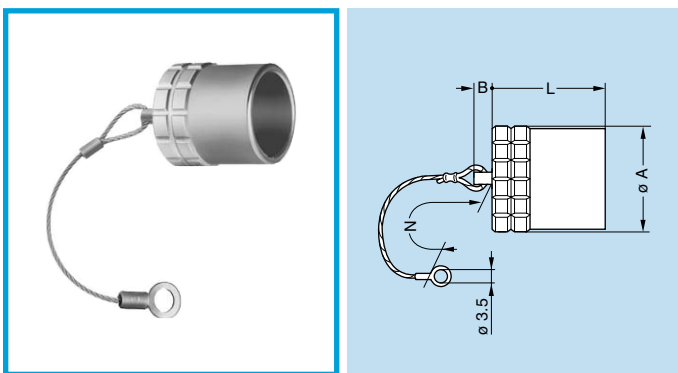

### BHG Plug caps, nut fixing or flange

Part number	Series	Dimensions (mm)				Availability
		A	B	L	N	
BHG.0K.100.NAS	0K	14.0	6	15.0	85	○
BHG.1K.100.NAS	1K	16.0	6	18.0	85	○
BHG.2K.100.NAS	2K	19.5	6	20.0	85	○
BHG.3K.100.NAS	3K	23.0	6	24.0	120	○
BHG.4K.100.NAS	4K	29.0	10	24.5	120	○
BHG.5K.100.NAS	5K	44.0	10	29.0	150	○
BHG.6E.100.NAS	6E	54.0	10	34.0	150	○

**Note:** This cap is available only with an alignment key (G). The last letter «S» of the part number stands for the material of the O-ring (silicone rubber). O-rings made from FPM are also available; if required, replace the letter «S» by «V».

- Body material: Nickel-plated brass (Ni 3µm)
- Lanyard material: Stainless steel
- Crimp ferrule material: Nickel-plated brass + polyolefin
- O-ring material: Silicone rubber or FPM
- Maximum operating temperature: 275° F
- Watertightness: IP68 according to IEC 60529 for E and K series

● Standard, typically 0-6 weeks delivery for quantities of 250 or less.

○ Non-standard product, contact LEMO USA, typically 6-12 weeks delivery for quantities of 250 or less.

Non-standard product is defined as any product which contains one or more components which are not standard.

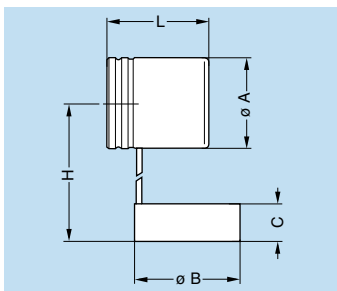

### BFA Plug cap

Part number	Series	Dimensions (mm)					Availability
		A	B	C	H	L	
BFA.3K.170.800EN	3K-3E	24	28	10	80	27	○

- Material: black EPDM
- Maximum operating temperature: 250° F

**Note:** These caps are suitable for use with any alignment key configuration.

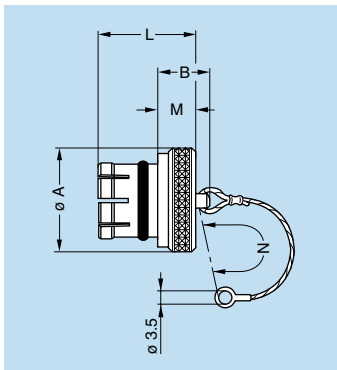

### BRE Blanking caps for fixed and free receptacles

Part number	Series	Dimensions (mm)					Availability
		A	B	L	M	N	
BRE.6E.200.NAS	6E	57	24.0	31.5	14.0	150	○

**Note:** These caps are suitable for use with any alignment key configuration. The last letter «S» of the part number stands for the O-ring material (silicone rubber). O-rings made from FPM are also available; if required, replace the letter «S» by «V».

- Body material: Nickel-plated brass (Ni 3 µm)
- Lanyard material: Stainless steel
- Crimp ferrule material: Nickel-plated brass + polyolefin
- O-ring material: Silicone rubber or FPM
- Maximum operating temperature: 275° F
- Watertightness: IP61 according to IEC 60529

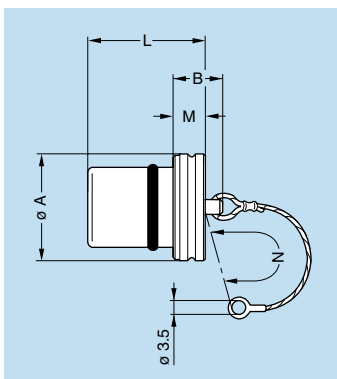

### BRE Blanking caps for fixed and free receptacles

Part number	Series	Dimensions (mm)					Availability
		A	B	L	M	N	
BRE.0K.200.NAS	0K-0E	15.0	10	15.0	4	85	○
BRE.1K.200.NAS	1K-1E	17.0	12	20.0	6	85	○
BRE.2K.200.NAS	2K-2E	20.5	14	24.0	8	85	○
BRE.3K.200.NAS	3K-3E	24.0	14	28.0	8	120	○
BRE.4K.200.NAS	4K-4E	30.0	20	30.5	10	120	○
BRE.5K.200.NAS	5K-5E	44.0	22	37.0	12	150	○

**Note:** These caps are suitable for use with any alignment key configuration. The last letter «S» of the part number stands for the O-ring material (silicone rubber). O-rings made from FPM are also available; if required, replace the letter «S» by «V».

- Body material: Nickel-plated brass (Ni 3 µm)
- Lanyard material: Stainless steel
- Crimp ferrule material: Nickel-plated brass + polyolefin
- O-ring material: Silicone rubber or FPM
- Maximum operating temperature: 275° F
- Watertightness: IP68 according to IEC 60529

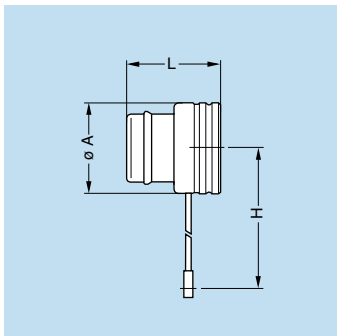

### BRA Blanking cap for fixed and free receptacles

Part number	Series	Dimensions (mm)			Availability
		A	H	L	
BRA.3K.100.715EN	3K-3E	24	80	25	○

- Material: black EPDM
- Maximum operating temperature: 250° F

**Note:** These caps are suitable for use with any alignment key configuration.

## ● Accessories

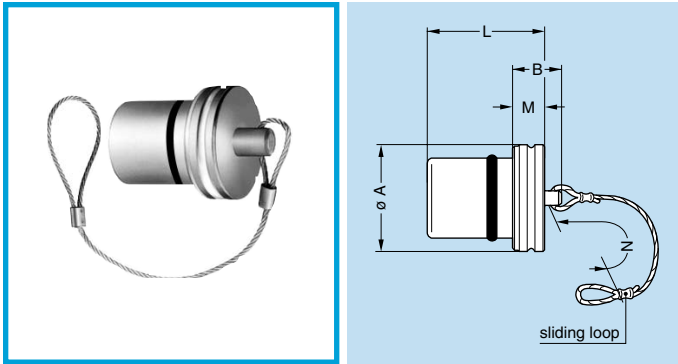

- Body material: Nickel-plated brass (Ni 3 µm)
- Lanyard material: Stainless steel
- Crimp ferrule material: Nickel-plated brass + polyolefin
- O-ring material: Silicone rubber or FPM

### BRF Blanking caps for free receptacles

Part number	Series	Dimensions (mm)					Availability
		A	B	L	M	N	
BRF.0K.200.NAS	0K-0E	15.0	10	15.0	4	85	○
BRF.1K.200.NAS	1K-1E	17.0	12	20.0	6	85	○
BRF.2K.200.NAS	2K-2E	20.5	14	24.0	8	85	○
BRF.3K.200.NAS	3K-3E	24.0	14	28.0	8	120	○
BRF.4K.200.NAS	4K-4E	30.0	20	30.5	10	120	○
BRF.5K.200.NAS	5K-5E	44.0	22	37.0	12	150	○

**Note:** These caps are suitable for use with any alignment key configuration. The last letter «S» of the part number stands for the O-ring material (silicone rubber). O-rings made from FPM are also available; if required, replace the letter «S» by «V».

- Maximum operating temperature: 275° F
- Watertightness: IP68 according to IEC 60529

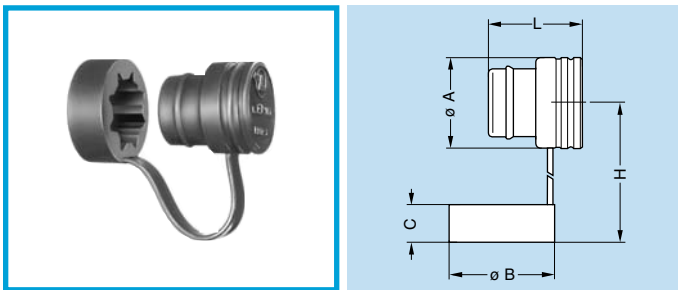

### BRD Blanking caps for free receptacles

Part number	Series	Dimensions (mm)					Availability
		A	B	C	H	L	
BRD.3K.170.800EN	3K-3E	24	28	10	80	25	○

- Material: black EPDM
- Maximum operating temperature: 250° F

**Note:** These caps are suitable for use with any alignment key configuration.



### BRR Spring loaded dust caps for ERA, ERN and EG receptacles or PSA and PK fixed receptacles

Part number	Series	Dimensions (mm)							Availability
		A	B	C	E	L	M	N	
BRR.3K.200.PZSG	3K	29.0	27.5	23.0	9.0	7.7	3.0	29.2	○

**Note:** On request, this cap is available in black. If so replace the last letter «G» of the part number by «N».

- Spring material: Stainless steel
- Maximum operating temperature: 212° F
- Watertightness: IP61 according to IEC 60529
- Body material: Polyoxymethylene (POM) gray (or black)
- Gasket material: Silicone rubber

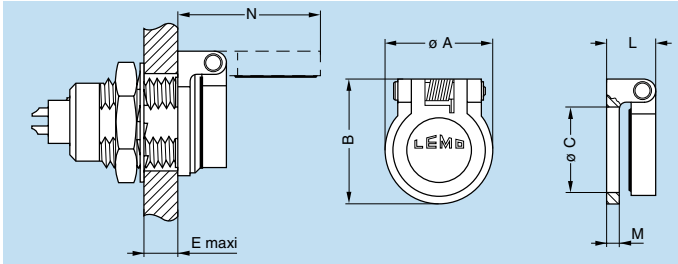

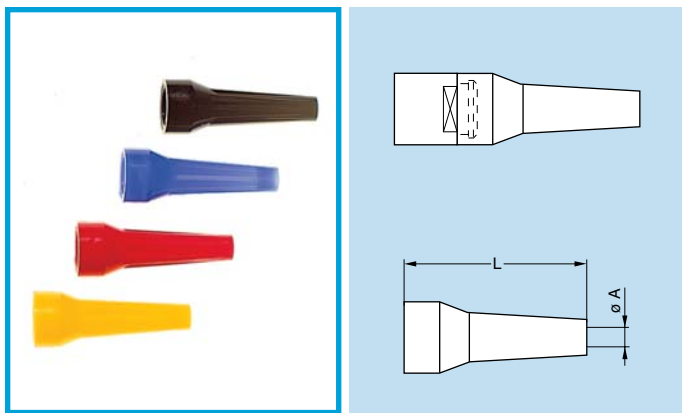

**GM• Bend relief (Polyurethane)**

A bend relief made from thermoplastic polyurethane elastomer (Desmopan 786) can be fitted over LEMO plugs and receptacles that are supplied with a specially fitted nut.

Use the part numbers shown below to order this accessory separately.



**Main characteristics**

- Material: Polyurethane elastomer
- Temperature range in dry atmosphere: -40° F to +176° F

Part number	Dimensions (mm)				Series	Part number of nut for fitting the bend relief	Note	Availability
	Bend relief		Cable ø					
	A	L	max.	min.				
GMA.0B.025.DG	2.5	24	2.9	2.5	0E-0K	FFM.0E.130.LC		●
GMA.0B.030.DG	3.0	24	3.4	3.0				●
GMA.0B.035.DG	3.5	24	3.9	3.5				●
GMA.0B.040.DG	4.0	24	4.4	4.0				●
GMA.0B.045.DG	4.5	24	5.2	4.5				●
GMA.1B.025.DG	2.5	30	2.9	2.5	1E-1K	FFM.1E.130.LC		○
GMA.1B.030.DG	3.0	30	3.4	3.0				●
GMA.1B.035.DG	3.5	30	3.9	3.5				●
GMA.1B.040.DG	4.0	30	4.4	4.0				●
GMA.1B.045.DG	4.5	30	4.9	4.5				●
GMA.1B.054.DG	5.4	30	6.0	5.4				●
GMA.1B.065.DG	6.5	30	7.0	6.5				●
GMA.2B.040.DG	4.0	36	4.5	4.0	2E-2K	FFM.2E.130.LC		○
GMA.2B.045.DG	4.5	36	5.0	4.5				●
GMA.2B.050.DG	5.0	36	5.5	5.0				●
GMA.2B.060.DG	6.0	36	6.5	6.0				●
GMA.2B.070.DG	7.0	36	7.7	7.0				●
GMA.2B.080.DG	7.8	36	8.8	7.8				●
GMA.3B.050.DG	4.5	42	5.2	4.5	3E-3K	FFM.3E.130.LC		●
GMA.3B.070.DG	7.0	42	7.9	7.0				●
GMA.3B.080.DG	8.0	42	8.9	8.0				●
GMA.3B.090.DG	9.0	42	10.0	9.0				●
GMA.4B.080.DG	8.0	60	9.0	8.0	4E-4K	FFM.4E.130.LC		○
GMA.4B.010.DG	10.0	60	10.9	10.0				○
GMA.4B.011.DG	11.0	60	11.9	11.0				○
GMA.4B.012.DG	12.0	60	13.0	12.0				○
GMA.4B.013.DG	13.5	60	14.5	13.5				○

**Note:** The last letter «G» of the part number indicates the gray color of the bend relief. For ordering a bend relief with another color, see table on page 92 and replace the letter «G» by the letter of the required color  
 See also detailed information for each series: K series on page 41; E series on page 80.

● Standard, typically 0-6 weeks delivery for quantities of 250 or less.  
 ○ Non-standard product, contact LEMO USA, typically 6-12 weeks delivery for quantities of 250 or less.  
 Non-standard product is defined as any product which contains one or more components which are not standard.

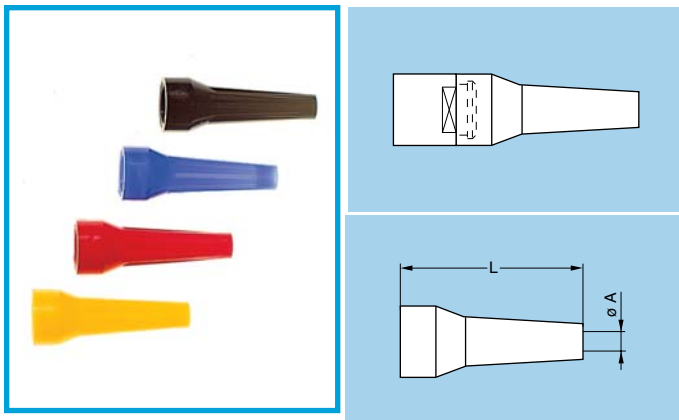

### GMA Bend relief (Silicone)

A bend relief has been designed for connectors used in applications at high temperature or requiring vapor sterilization.

These bend reliefs are different from previous ones; their material, a silicone elastomer, is noted for its retention of flexibility over a wide temperature range. They are available in nine colors.

Use the part numbers shown below to order this accessory separately.

#### Main characteristics

- Material: Silicone elastomer VMQ
- Temperature range in dry atmosphere: -106° F to +392° F
- Temperature range in water steam: +284° F
- Inflammability: not flammable (no UL classification)

Part number	Dimensions (mm)				Series	Part number of nut for fitting the bend relief	Availability
	Bend relief		Cable ø				
	A	L	max.	min.			
GMA.0B.025.RG	2.5	27	2.9	2.5	0E-0K	FFM.0E.130.LC	○
GMA.0B.030.RG	3.0	27	3.4	3.0			○
GMA.0B.035.RG	3.5	27	3.9	3.5			○
GMA.0B.040.RG	4.0	27	4.4	4.0			○
GMA.0B.045.RG	4.5	27	5.2	4.5			○
GMA.1B.025.RG	2.5	34	2.9	2.5	1E	FFM.1E.130.LC	○
GMA.1B.030.RG	3.0	34	3.4	3.0			○
GMA.1B.035.RG	3.5	34	3.9	3.5			○
GMA.1B.040.RG	4.0	34	4.4	4.0			○
GMA.1B.045.RG	4.5	34	5.0	4.5			○
GMA.1B.051.RG	5.1	34	5.6	5.1			○
GMA.1B.057.RG	5.7	34	6.2	5.7			○
GMA.1B.063.RG	6.3	34	7.0	6.3			○
GMA.2B.040.RG	4.0	41	4.4	4.0	2E-2K	FFM.2E.130.LC	○
GMA.2B.045.RG	4.5	41	5.0	4.5			○
GMA.2B.051.RG	5.1	41	5.6	5.1			○
GMA.2B.057.RG	5.7	41	6.2	5.7			○
GMA.2B.063.RG	6.3	41	7.0	6.3			○
GMA.2B.071.RG	7.1	41	7.9	7.1			○
GMA.2B.080.RG	8.0	41	9.0	8.0			○

**Note:** The last letter «G» of the part number indicates the gray color of the bend relief. For ordering a bend relief with another color, see table below and replace the letter «G» by the letter of the required color. See also detailed information for each series: K series on page 41; E series on page 80.

**Note:** The selection of pigments, which should remain stable at high temperature, is limited by new regulations. For this reason, some colors will be a shade different from those used for Desmopan bend reliefs. The selected solutions represent the best possible compromise.

Ref.	Color
A	blue
B	white
G	gray
J	yellow
M	brown

Ref.	Color
N	black
R	red
S	orange
V	green

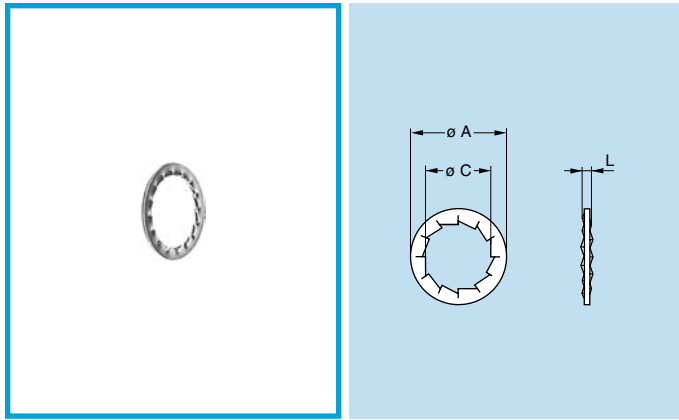

### GBA Locking washers

Part number	Series	Dimensions (mm)		
		A	C	L
GBA.1E.250.FN	1E-1K	21.8	16.1	1.2

**Note:** To order this accessory separately, use the above part numbers.

- Material: Nickel-plated bronze (3  $\mu$ m)

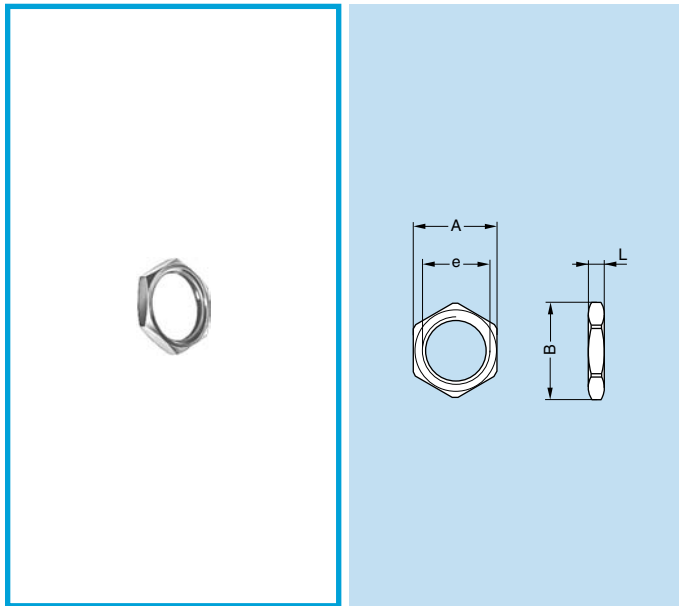

### GEA Hexagonal nuts

Part number	Series	Dimensions (mm)			
		A	B	e	L
GEA.0E.240.LN	0E-0K	17	19.2	M14 x 1.00	2.5
GEA.1E.240.LN	1E-1K	19	21.5	M16 x 1.00	3.0
GEA.2E.240.LN	2E-2K	24	27.0	M20 x 1.00	4.0
GEA.3E.240.LN	3E-3K	30	34.0	M24 x 1.00	5.0
GEA.4E.240.LN	4E-4K	36	40.5	M30 x 1.00	7.0

**Note:** To order this part separately, use the above part numbers. The last letters «LN» of the part number refer to the nut material and treatment. If a nut in aluminium alloy or stainless steel is desired, replace the last letters of the part number by «PT» or «AZ» respectively.

- Material:
  - Nickel-plated brass (3  $\mu$ m)
  - Natural anodized aluminium alloy
  - Stainless steel

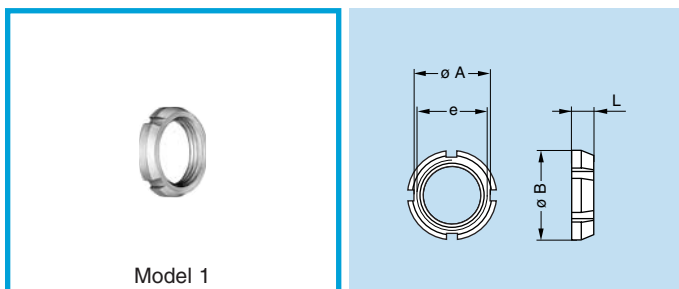

Model 1

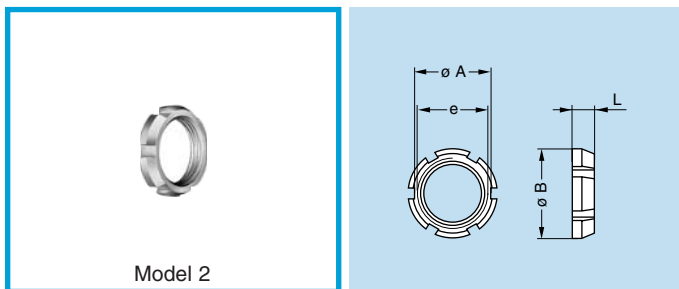

Model 2

### GEG Notched nut

Part number	Model	Dimensions (mm)			
		A	B	e	L
GEG.0S.240.LC	1	10.5	12	M9 x 0.6	2.5
GEG.0E.240.LC	1	15.8	18	M14 x 1.0	3.5
GEG.1S.240.LC	1	14.0	16	M12 x 1.0	3.5
GEG.1E.240.LC	2	17.5	20	M16 x 1.0	3.5
GEG.1S.242.LC	1	12.1	14	M11 x 0.5	3.5
GEG.2S.240.LC	2	17.5	20	M15 x 1.0	3.5
GEG.2S.241.LC	2	20.5	24	M19 x 1.0	3.5
GEG.2E.240.LC	2	22.5	25	M20 x 1.0	3.5

- Material: Chrome-plated brass (Ni 3  $\mu$ m + Cr 0.3  $\mu$ m)

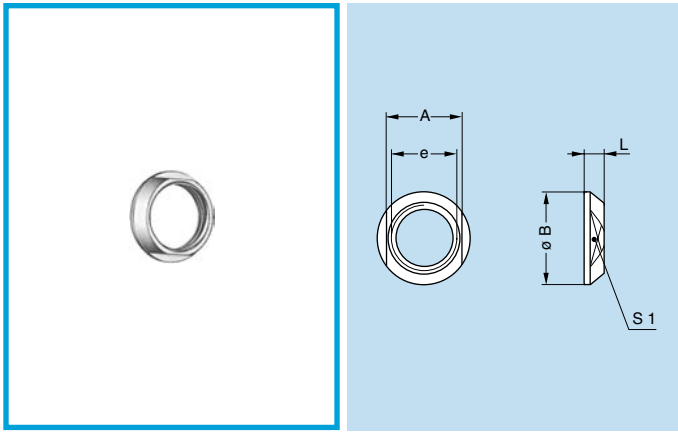

● Material: Chrome-plated brass (Ni 3 μm + Cr 0.3 μm)

**Note:** 3K, 3E, 4K, 4E, 5K, 5E, and 6E series fixed and free receptacles for back panel mounting are always delivered with a conical nut. To order this accessory separately, use the part numbers in the adjacent table.

### GEC Conical nuts

Part number	Dimensions (mm)				
	A	B	e	L	S1
GEC.0S.240.LC	10	12.0	M9 x 0.6	2.5	10
GEC.0E.240.LC	16	18.0	M14 x 1.0	3.0	16
GEC.1S.240.LC	13	16.0	M12 x 1.0	3.2	13
GEC.1S.241.LC	17	20.0	M16 x 1.0	4.0	17
GEC.1S.242.LC	12	14.0	M11 x 0.5	3.2	12
GEC.2S.240.LC	17	20.0	M15 x 1.0	3.8	17
GEC.2S.241.LC	20	24.0	M19 x 1.0	5.8	20
GEC.2E.240.LC	22	25.0	M20 x 1.0	5.0	20
GEC.3S.240.LC	20	24.0	M18 x 1.0	4.5	20
GEC.3E.240.LC	27	30.0	M24 x 1.0	4.5	24
GEC.4S.240.LC	27	30.0	M25 x 1.0	4.5	27
GEC.4K.241.LC	32	35.5	M30 x 1.0	5.0	36
GEC.5S.240.LC	37	41.0	M35 x 1.0	5.0	37

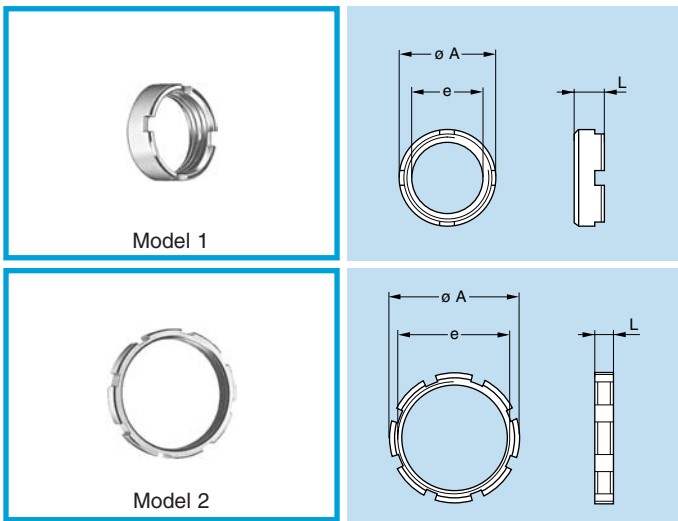

● Material: Nickel-plated brass (3 μm)

**Note:** 5K, 5E, and 6E series receptacles are always supplied with model 2 round nuts. To order this accessory separately, use the part numbers in the adjacent table.

### GEB Round nuts

Part number	Model	Dimensions (mm)		
		A	e	L
GEB.0S.240.LN	1	11.0	M9 x 0.60	4.0
GEB.0E.240.LN	1	18.0	M14 x 1.00	5.0
GEB.1S.240.LN	1	14.0	M12 x 1.00	5.0
GEB.1E.240.LN	1	20.0	M16 x 1.00	5.0
GEB.2S.240.LN	1	18.0	M15 x 1.00	5.5
GEB.2B.240.LN	2	17.5	M15 x 0.75	2.5
GEB.3S.240.LN	1	22.0	M18 x 1.00	5.5
GEB.4S.240.LN	1	28.0	M25 x 1.00	6.0
GEB.5S.240.LN	2	40.0	M35 x 1.00	8.0
GEB.5E.240.LN	2	54.0	M45 x 1.50	8.0
GEB.6S.241.LN	2	54.0	M48 x 1.50	8.0
GEB.6E.240.LN	2	65.0	M55 x 2.00	9.0

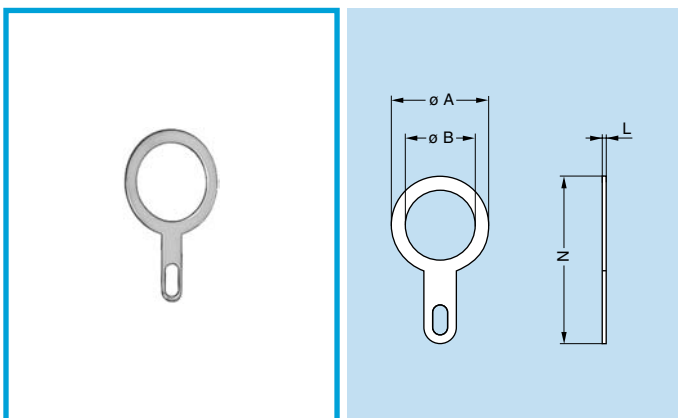

● Material: CuSnZn plated brass (2 μm)

### GCA Grounding lug

Part number	Series	Dimensions (mm)			
		A	B	L	N
GCA.0E.255.LT	0E-0K	17	14.1	0.5	27.5
GCA.1E.255.LT	1E-1K	20	16.2	0.5	32.0
GCA.2E.255.LT	2E-2K	25	20.2	0.5	39.0
GCA.4E.255.LT	4E-4K	35	30.6	0.6	50.0



## ● Tooling

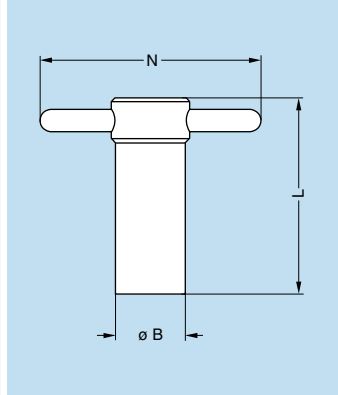
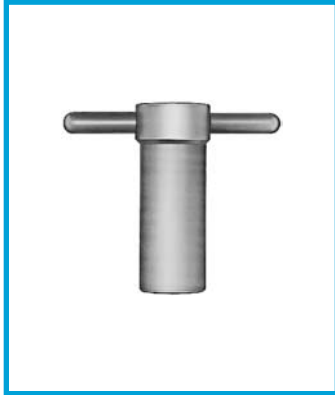

### DCG Wrench for hexagonal nuts

Part number	Dimensions (mm)			Part number of the nut
	B	L	N	
DCG.91.161.1TN	16	45	52	GEA.0S.240.LN
DCG.91.201.4TN	20	52	65	GEA.1S.240.LN
DCG.91.231.7TN	23	62	68	GEA.2S.240.LN
DCG.91.282.2TN	28	76	73	GEA.3S.240.LN

- Material: blackened steel

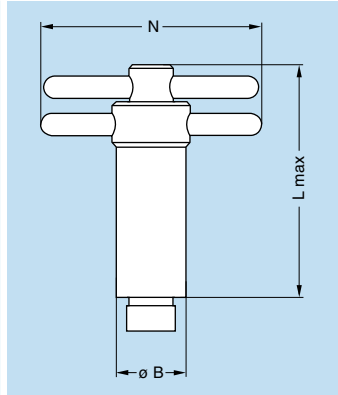
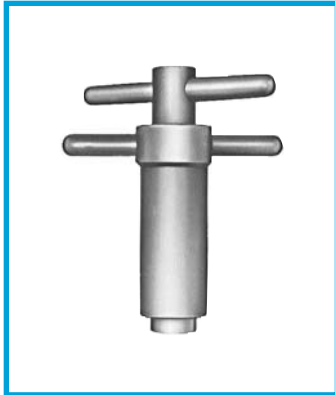

### DCA Wrench for hexagonal nuts, with alignment of the receptacles by the flats

Part number	Dimensions (mm)			Part number of the nut
	B	L	N	
DCA.91.161.1TN	16	73	52	GEA.0S.240.LN
DCA.91.201.4TN	20	85	65	GEA.1S.240.LN
DCA.91.231.7TN	23	100	68	GEA.2S.240.LN
DCA.91.282.2TN	28	120	73	GEA.3S.240.LN

- Material: blackened steel

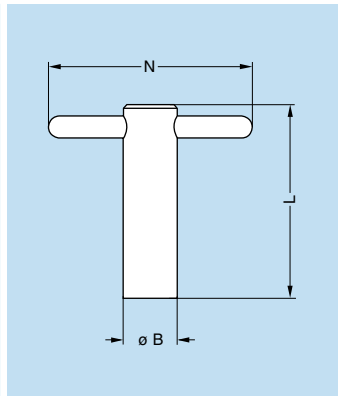
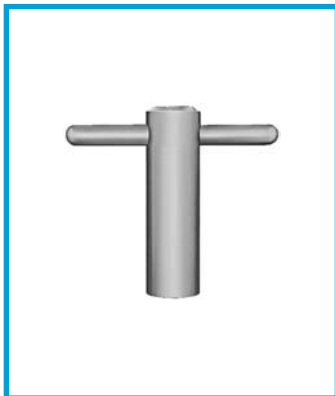

### DCB Spanner type wrench for model 1 round nuts

Part number	Dimensions (mm)			Part number of the nut
	B	L	N	
DCB.91.131.1TN	13	45	50	GEB.0S.240.LN
DCB.91.161.4TN	16	52	65	GEB.1S.240.LN
DCB.91.201.8TN	20	62	65	GEB.2S.240.LN
DCB.91.242.2TN	24	76	70	GEB.3S.240.LN

- Material: blackened steel

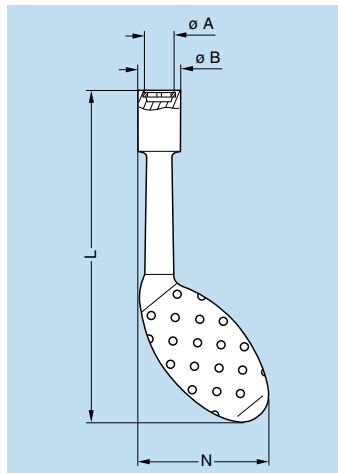

### DCH Wrench for conical nut

Part number	Dimensions (mm)				Part number of the nut
	A	B	L	N	
DCH.91.121.PN	12.1	14.8	124	49.3	GEC.0S.240.LC
DCH.91.161.PN	16.1	21.0	124	51.9	GEC.1S.240.LC
DCH.91.201.PN	20.1	22.8	129	53.5	GEC.2S.240.LC

- Material: Dark gray polyurethane

● Standard, typically 0-6 weeks delivery for quantities of 250 or less.  
 ○ Non-standard product, contact LEMO USA, typically 6-12 weeks delivery for quantities of 250 or less.  
 Non-standard product is defined as any product which contains one or more components which are not standard.

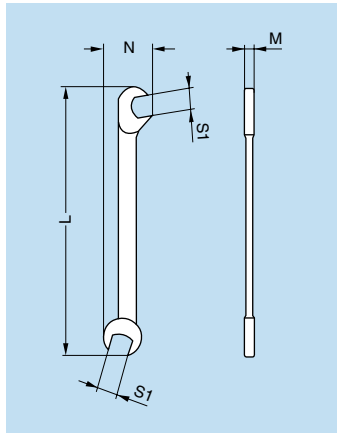
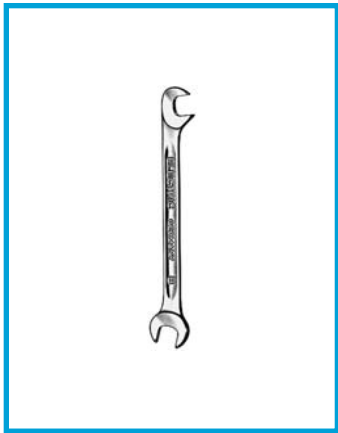

### DCP Flat wrench for collet nut

Part number	Dimensions (mm)			
	L	M	N	S1
DCP.99.045.TC	70	2	10.5	4.5
DCP.99.050.TC	78	2	12.6	5.0
DCP.99.055.TC	78	2	12.6	5.5
DCP.99.060.TC	78	2	12.6	6.0

- Material: chrome-plated steel

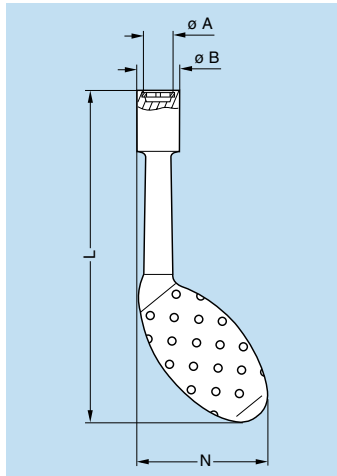

### DCH Wrench for notched nuts

Part number	Dimensions (mm)				Part number of the nut
	A	B	L	N	
DCH.91.121.PA	12.1	14.8	124	49.3	GEG.0S.240.LC
DCH.91.181.PA	18.1	22.8	129	53.1	GEG.0E.240.LC
DCH.91.161.PA	16.1	21.0	124	51.2	GEG.1S.240.LC
DCH.91.201.PA	20.1	22.8	129	53.5	GEG.1E.240.LC
DCH.91.141.PA	14.1	18.6	124	51.2	GEG.1S.242.LC
DCH.91.201.PA	20.1	22.8	129	53.5	GEG.2S.240.LC
DCH.91.241.PA	24.1	30.8	134	52.6	GEG.2S.241.LC
DCH.91.251.PA	25.1	32.8	134	55.5	GEG.2E.240.LC

- Material: Blue polyurethane

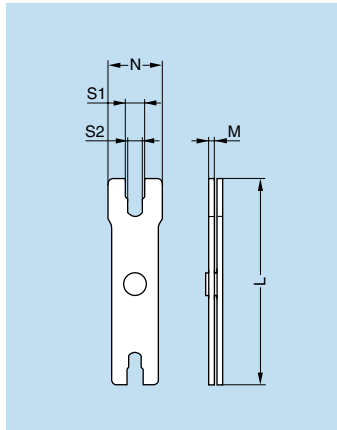

### DCP Wrench for tightening backnut

Part number	Series	Dimensions (mm)				
		L	M	N	S1	S2
DCP.91.023.TN	2K	115	3.0	30	13.1	12.1
	3K	115	3.0	35	15.1	14.1

- Material: blackened steel

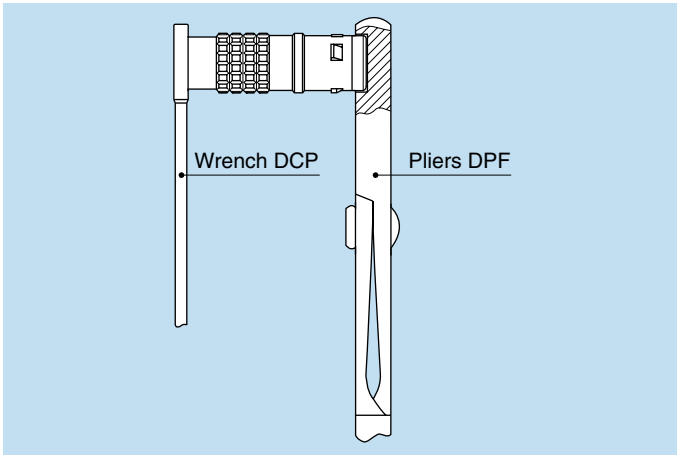
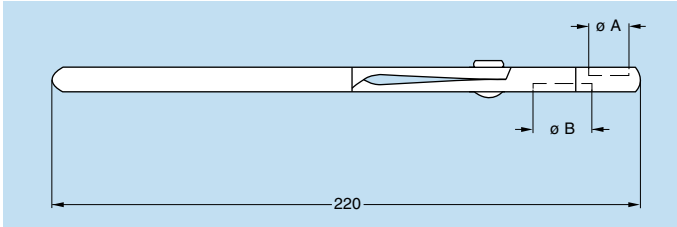

**DPF Pliers for assembling plugs (series K and E)**

Part number	Series	Dimensions (mm)	
		A	B
DPF.91.001.TA	0E-0K	10	–
	1E-1K	–	12
DPF.91.023.TA	2E-2K	15	–
	3E-3K	–	18

**Example for use**

The plug end must be held in the pliers while the nut is tightened with the wrench.

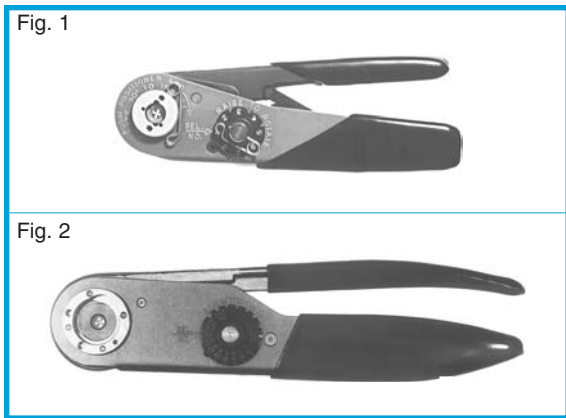

### Manual crimping tools

Supplier	Part number		
	contact ø 0.5-0.7 0.9-1.3 (Fig. 1)	contact ø 1.6-2.0 (Fig. 2)	contact ø 3.0-4.0 (Fig. 2)
LEMO	DPC.91.701.V <sup>1)</sup>	DPC.91.101.A <sup>2)</sup>	DPC.91.102.V
DANIELS	MH860 <sup>1)</sup>	AF8 <sup>2)</sup>	M300BT
BALMAR	23-000	55-000	55-000
BUCHANAN	616336 <sup>1)</sup>	615708 <sup>2)</sup>	615708

1) According to specification MIL-C-22520/7-01.  
2) According to specification MIL-C-22520/1-01.



### DPE Manual crimp tool for coax contacts

	Connector			Part Number
	Type	Coax Groups	Cable Groups	
<b>2K</b>	810	C	1,3	DPE.99.103.8K
	810	C	2	DPE.99.103.1K
<b>3K</b>	242/243	C	1,3	DPE.99.103.8K
	242/243	C	2	DPE.99.103.1K
	822/844/846	C	1,3	DPE.99.103.8K
	822/844/846	C	2	DPE.99.103.1K
	850/856/862	C	1,3	DPE.99.103.8K
	850/856/862	C	2	DPE.99.103.1K
<b>4K</b>	244	C	1,3	DPE.99.103.8K
	244	C	2	DPE.99.103.1K
	852/856/858	C	1,3	DPE.99.103.8K
	852/856/858	C	2	DPE.99.103.1K
	866/879/885	C	1,3	DPE.99.103.8K
	866/879/885	C	2	DPE.99.103.1K
<b>5K</b>	240	C	1,3	DPE.99.103.8K
	240	C	2	DPE.99.123.1K
	260	D	1,3	DPE.99.006.2K
	260	D	2	DPE.99.006.2K
	273/274	B	5	DPE.99.127.0K
	273/274	B	3	DPE.99.123.8K
	273/274	B	0	DPE.99.178.5K
	850/856/857	B	1	DPE.99.173.8K
	850/856/857	B	2	DPE.99.123.1K
	850/856/857	B	6	DPE.99.176.2K
	864/870/876	B	3	DPE.99.123.8K
	864/870/876	B	5	DPE.99.127.0K
	877	B	3	DPE.99.123.8K
	877	B	5	DPE.99.127.0K
	892	D	1,3	DPE.99.006.2K
892	D	2	DPE.99.006.2K	



### Pneumatic crimping tools

Supplier	Part number
LEMO	DPC.91.701.C
BALMAR	85230
BUCHANAN	621101

According to specification MIL-C-22520/7-01.  
For LEMO contacts ø 0.5-0.7-0.9-1.3 mm

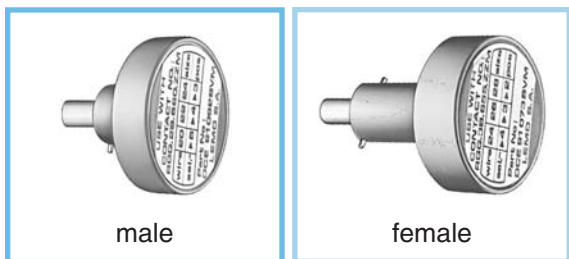

These positioners are suitable for use with both manual and pneumatic crimping tools according to the MIL-C-22520/7-01 standard.

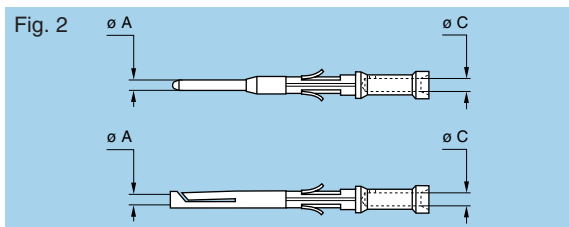
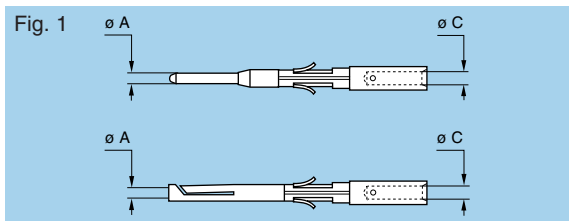

**Note:** A wide variation of strand number and diameter combinations are quoted as being AWG, some of which do not have a large enough cross section to guarantee a crimp as per either MIL-C-22520/1-01 or /7-01. Our technical department is at your disposal to study and propose a solution to all your applications.

**Note:** See table on page 85 to 87 for contact selection.

### DCE Positioners for crimp contacts $\varnothing$ 0.5-0.7-0.9 and 1.3 mm

	Connector + Contact				Positioners part number		
	Type	$\varnothing$ A	$\varnothing$ C	Fig.	Conductor AWG	For male contact	For female contact
<b>OK</b>	302 303	0.9	1.10	1	20,22,24	DCE.91.090.BVC	DCE.91.090.BVM
		0.9	0.80	2	22,24,26	DCE.91.090.AVC	DCE.91.090.AVM
		0.9	0.45	2	28,30,32	DCE.91.090.AVC	DCE.91.090.AVM
	304/305	0.7	0.80	1	22,24,26	DCE.91.070.BVC	DCE.91.070.BVM
		0.7	0.45	2	28,30,32	DCE.91.070.BVC	DCE.91.070.BVM
306/307 309	0.5	0.45	1	28,30,32	DCE.91.050.BVC	DCE.91.050.BVM	
<b>1K</b>	302 303	1.3	1.40	1	18,20	DCE.91.131.BVC	DCE.91.131.BVM
		1.3	1.10	2	20,22,24	DCE.91.131.BVC	DCE.91.131.BVM
	304 305	0.9	1.10	1	20,22,24	DCE.91.091.BVC	DCE.91.091.BVM
		0.9	0.80	2	22,24,26	DCE.91.091.BVC	DCE.91.091.BVM
	306/307 308	0.7	0.80	1	22,24,26	DCE.91.071.BVC	DCE.91.071.BVM
		0.7	0.45	2	28,30,32	DCE.91.071.BVC	DCE.91.071.BVM
	702/731	1.3	1.40	1	18,20	DCE.91.131.BVC	DCE.91.131.BVM
1.3		1.10	2	20,22,24	DCE.91.131.BVC	DCE.91.131.BVM	
<b>2K</b>	304/305 306 307	1.3	1.40	1	18,20	DCE.91.132.BVC	DCE.91.132.BVM
		1.3	1.10	2	20,22,24	DCE.91.132.CVC	DCE.91.132.CVM
		1.3	0.80	2	22,24,26	DCE.91.132.CVC	DCE.91.132.CVM
	308/310	0.9	1.10	1	20,22,24	DCE.91.092.BVC	DCE.91.092.BVM
		0.9	0.80	2	22,24,26	DCE.91.092.BVC	DCE.91.092.BVM
		0.9	0.45	2	28,30,32	DCE.91.092.AVC	DCE.91.092.AVM
	312/314 316/318 319	0.7	0.80	1	22,24,26	DCE.91.072.BVC	DCE.91.072.BVM
		0.7	0.45	2	28,30,32	DCE.91.072.BVC	DCE.91.072.BVM
	704	0.7	0.80	1	22,24,26	DCE.91.072.BVC	DCE.91.072.BVM
		0.7	0.45	2	28,30,32	DCE.91.072.BVC	DCE.91.072.BVM
	706	1.3	1.40	1	18,20	DCE.91.132.BVC	DCE.91.132.BVM
		1.3	1.10	2	20,22,24	DCE.91.132.CVC	DCE.91.132.CVM
		1.3	0.80	2	22,24,26	DCE.91.132.CVC	DCE.91.132.CVM
	708	0.9	1.10	1	20,22,24	DCE.91.092.BVC	DCE.91.092.BVM
		0.9	0.80	2	22,24,26	DCE.91.092.BVC	DCE.91.092.BVM
	802	0.9	1.10	1	20,22,24	DCE.91.092.BVC	DCE.91.092.BVM
		0.9	0.80	2	22,24,26	DCE.91.092.AVC	DCE.91.092.AVM
		0.9	0.45	2	28,30,32	DCE.91.092.AVC	DCE.91.092.AVM
	804/806 810	0.7	0.80	1	22,24,26	DCE.91.072.BVC	DCE.91.072.BVM
0.7		0.45	2	28,30,32	DCE.91.072.BVC	DCE.91.072.BVM	
<b>3K</b>	308/309 310	1.3	1.40	1	18,20	DCE.91.133.BVC	DCE.91.133.BVM
		1.3	1.10	2	20,22,24	DCE.91.133.BVC	DCE.91.133.BVM
	312/314 316/318	0.9	1.10	1	20,22,24	DCE.91.093.BVC	DCE.91.093.BVM
		0.9	0.80	2	22,24,26	DCE.91.093.BVC	DCE.91.093.BVM
	320/322 324/326 328/330	0.7	0.80	1	22,24,26	DCE.91.073.BVC	DCE.91.073.BVM
		0.7	0.45	2	28,30,32	DCE.91.073.BVC	DCE.91.073.BVM
	709	0.7	0.80	1	22,24,26	DCE.91.073.BVC	DCE.91.073.BVM
		0.7	0.45	2	28,30,32	DCE.91.073.BVC	DCE.91.073.BVM
	712	0.9	1.10	1	20,22,24	DCE.91.093.BVC	DCE.91.093.BVM
		0.9	0.80	2	22,24,26	DCE.91.093.BVC	DCE.91.093.BVM
	718/740	0.7	0.80	1	22,24,26	DCE.91.073.BVC	DCE.91.073.BVM
		0.7	0.45	2	28,30,32	DCE.91.073.BVC	DCE.91.073.BVM
	803	0.9	1.10	1	20,22,24	DCE.91.093.BVC	DCE.91.093.BVM
		0.9	0.80	2	22,24,26	DCE.91.093.BVC	DCE.91.093.BVM
	806/809	0.7	0.80	1	22,24,26	DCE.91.073.BVC	DCE.91.073.BVM
		0.7	0.45	2	28,30,32	DCE.91.073.BVC	DCE.91.073.BVM

● Standard, typically 0-6 weeks delivery for quantities of 250 or less.  
 ○ Non-standard product, contact LEMO USA, typically 6-12 weeks delivery for quantities of 250 or less.  
 Non-standard product is defined as any product which contains one or more components which are not standard.

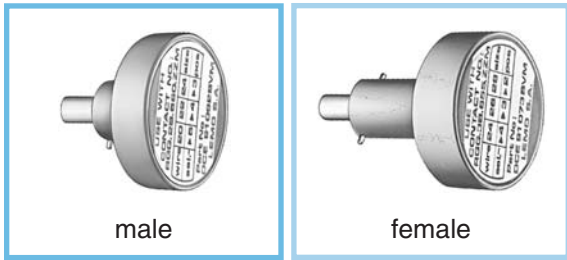

male

female

These positioners are suitable for use with both manual and pneumatic crimping tools according to the MIL-C-22520/7-01 standard.

### DCE Positioners for crimp contacts 0.5-0.7-0.9 and 1.3 mm diameter

<b>3K</b>	812	0.9	1.10	1	20,22,24	DCE.91.093.BVC	DCE.91.093.BVM
		0.9	0.80	2	22,24,26		
	813/822	0.7	0.80	1	22,24,26	DCE.91.073.BVC	DCE.91.073.BVM
		0.7	0.45	2	28,30,32		
	844/846	0.9	1.10	1	20,22,24	DCE.91.093.BVC	DCE.91.093.BVM
		0.9	0.80	2	22,24,26		
850/856	0.7	0.80	1	22,24,26	DCE.91.073.BVC	DCE.91.073.BVM	
	0.7	0.45	2	28,30,32			
862	0.9	1.10	1	20,22,24	DCE.91.093.BVC	DCE.91.093.BVM	
	0.9	0.80	2	22,24,26			
<b>4K</b>	312	1.3	1.40	1	18,20	DCE.91.134.BVC	DCE.91.134.BVM
		1.3	1.10	2	20,22,24		
	316/320 324/330	0.9	1.10	1	20,22,24	DCE.91.094.BVC	DCE.91.094.BVM
		0.9	0.80	2	22,24,26		
	340	0.7	0.80	1	22,24,26	DCE.91.074.BVC	DCE.91.074.BVM
		0.7	0.45	2	28,30,32		
	745	0.9	1.10	1	20,22,24	DCE.91.094.BVC	DCE.91.094.BVM
		0.9	0.80	2	22,24,26		
	802/804 806/822 824/826 842/844 852/856	0.9	1.10	1	20,22,24	DCE.91.094.BVC	DCE.91.094.BVM
		0.9	0.80	2	22,24,26		
	858/866 879/885	0.7	0.80	1	22,24,26	DCE.91.074.BVC	DCE.91.074.BVM
		0.7	0.45	2	28,30,32		
<b>5K</b>	330/340 348	1.3	1.40	1	18,20	DCE.91.135.BVC	DCE.91.135.BVM
		1.3	1.10	2	20,22,24		
	350/354 364	0.9	1.10	1	20,22,24	DCE.91.095.BVC	DCE.91.095.BVM
		0.9	0.80	2	22,24,26		
	752	1.3	1.40	1	18,20	DCE.91.135.BVC	DCE.91.135.BVM
		1.3	1.10	2	20,22,24		
	759/850 856/857	0.9	1.10	1	20,22,24	DCE.91.095.BVC	DCE.91.095.BVM
		0.9	0.80	2	22,24,26		
	864	1.3	1.40	1	18,20	DCE.91.135.BVC	DCE.91.135.BVM
		1.3	1.10	2	20,22,24		
	870/876 877/892	0.9	1.10	1	20,22,24	DCE.91.095.BVC	DCE.91.095.BVM
		0.9	0.80	2	22,24,26		
	997	1.3	1.40	1	18,20	DCE.91.135.BVC	DCE.91.135.BVM
		1.3	1.10	2	20,22,24		

● Standard, typically 0-6 weeks delivery for quantities of 250 or less.

○ Non-standard product, contact LEMO USA, typically 6-12 weeks delivery for quantities of 250 or less.

Non-standard product is defined as any product which contains one or more components which are not standard.



**Note:** These turrets can be used with manual crimping tool according to MIL-C-22520/1-01 standard.

**DCE Turret for crimp contacts 1.6-2.0-3.0 and 4.0 mm diameter**

	Connector + Contact					Positioners
	Type	ø A	ø C	L <sub>g</sub>	Conductor AWG	Part number
<b>2K</b>	302	2.0	2.4	1	12,14,16	DCE.91.202.BVCM
		2.0	1.9	2	14,16,18	
	303	1.6	1.9	1	14,16,18	DCE.91.162.BVCM
		1.6	1.4	2	18,20,22	
<b>3K</b>	302	3.0	2.9	1	10,12,14	DCE.91.303.BVCM
	303/304 309	2.0	2.4	1	12,14,16	DCE.91.203.BVCM
		2.0	1.9	2	14,16,18	
	305/306 307	1.6	1.9	1	14,16,18	DCE.91.163.BVCM
		1.6	1.4	2	18,20,22	
	<b>4K</b>	304	3.0	2.9	1	10,12,14
306/307		2.0	2.4	1	12,14,16	DCE.91.204.BVCM
		2.0	1.9	2	14,16,18	
310		1.6	1.9	1	14,16,18	DCE.91.164.BVCM
		1.6	1.4	2	18,20,22	
<b>5K</b>		304	4.0	4.0	1	8,10,12
	310	3.0	2.9	1	10,12,14	DCE.91.305.BVCM
	314/316	2.0	2.4	1	12,14,16	DCE.91.205.BVCM
		2.0	1.9	2	14,16,18	
	320	1.6	1.9	1	14,16,18	DCE.91.165.BVCM
		1.6	1.4	2	18,20,22	
	752	1.6	1.9	1	14,16,18	DCE.91.165.BVCM
		1.6	1.4	2	18,20,22	
	857/877	2.0	2.4	1	12,14,16	DCE.91.205.BVCM
		2.0	1.9	2	14,16,18	

● Standard, typically 0-6 weeks delivery for quantities of 250 or less.  
 ○ Non-standard product, contact LEMO USA, typically 6-12 weeks delivery for quantities of 250 or less.  
 Non-standard product is defined as any product which contains one or more components which are not standard.

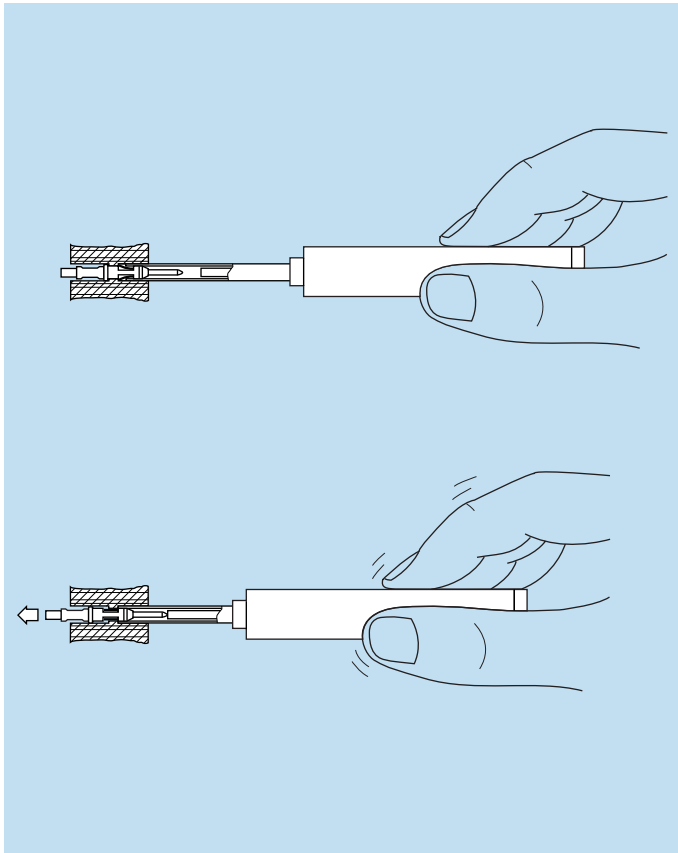
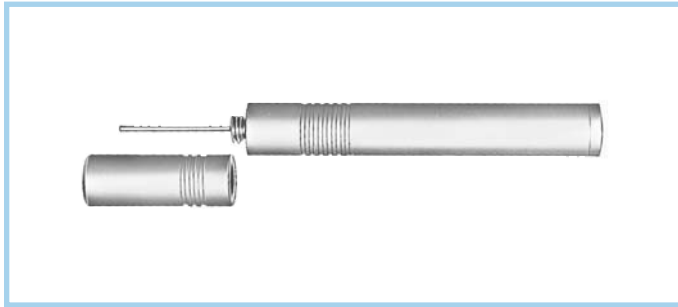

**Note:** This model is used for male and female contacts.

### DCF Extraction tools for crimp contacts

	Connector		Extractors	
	Type	Contact ø A	Part number	
<b>0K</b>	302/303	0.9	DCF.91.090.2LT	
	304/305	0.7	DCF.91.070.2LT	
	306/307/309	0.5	DCF.91.050.2LT	
<b>1K</b>	302/303	1.3	DCF.91.131.2LT	
	304/305	0.9	DCF.91.090.2LT	
	306/307/308	0.7	DCF.91.070.2LT	
	702/731	1.3	DCF.91.131.2LT	
<b>2K</b>	302	2.0	DCF.91.202.2LT	
	303	1.6	DCF.91.162.2LT	
	304/305/306/307	1.3	DCF.91.131.2LT	
	308/310	0.9	DCF.91.090.2LT	
	312/314/316/318/319	0.7	DCF.91.070.2LT	
	704	0.7	DCF.91.070.2LT	
	706	1.3	DCF.91.131.2LT	
	708	0.9	DCF.91.090.2LT	
	802	0.9	DCF.91.090.2LT	
	804/806/810	0.7	DCF.91.070.2LT	
	<b>3K</b>	302	3.0	DCF.91.303.5LT
		303/304/309	2.0	DCF.91.203.5LT
		305/306/307	1.6	DCF.91.163.5LT
308/309/310		1.3	DCF.91.133.5LT	
312/314/316/318		0.9	DCF.91.093.5LT	
320/322/324/326/330		0.7	DCF.91.073.5LT	
709		0.7	DCF.91.073.5LT	
712		0.9	DCF.91.093.5LT	
718/740		0.7	DCF.91.073.5LT	
803		0.9	DCF.91.093.5LT	
806/809		0.7	DCF.91.073.5LT	
812		0.9	DCF.91.093.5LT	
813/822		0.7	DCF.91.073.5LT	
844/846		0.9	DCF.91.093.5LT	
850/856		0.7	DCF.91.073.5LT	
862		0.9	DCF.91.093.5LT	
<b>4K</b>		304	3.0	DCF.91.303.5LT
		306/307	2.0	DCF.91.203.5LT
	310	1.6	DCF.91.163.5LT	
	312	1.3	DCF.91.133.5LT	
	316/320/324/330	0.9	DCF.91.093.5LT	
	340	0.7	DCF.91.073.5LT	
	745	0.9	DCF.91.093.5LT	
	802/804/806/822/824	0.9	DCF.91.093.5LT	
	826/842/844/852/856	0.9	DCF.91.093.5LT	
	858/866/879/885	0.7	DCF.91.073.5LT	



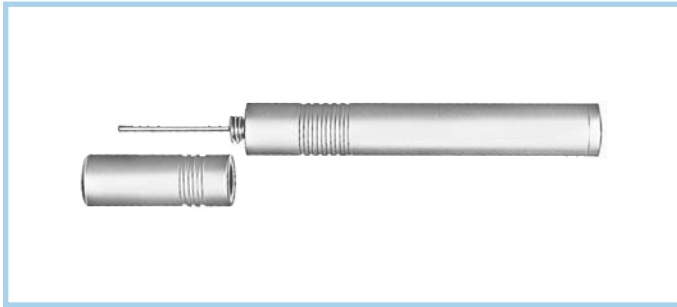

**DCF Extraction tools for crimp contacts**

	Connector		Extractors
	Type	Contact $\varnothing$ A	Part number
<b>5K</b>	304	4.0	DCF.91.405.5LT
	310	3.0	DCF.91.303.5LT
	314/316	2.0	DCF.91.203.5LT
	320	1.6	DCF.91.163.5LT
	330/340/348	1.3	DCF.91.133.5LT
	350/354/364	0.9	DCF.91.093.5LT
	752	1.3	DCF.91.133.5LT
	752	1.6	DCF.91.163.5LT
	759	0.9	DCF.91.093.5LT
	850/856/857	0.9	DCF.91.093.5LT
	857	2.0	DCF.91.203.5LT
	864	1.3	DCF.91.133.5LT
	870/876/877	0.9	DCF.91.093.5LT
	877	2.0	DCF.91.203.5LT
	892	0.9	DCF.91.093.5LT
	997	1.3	DCF.91.133.5LT

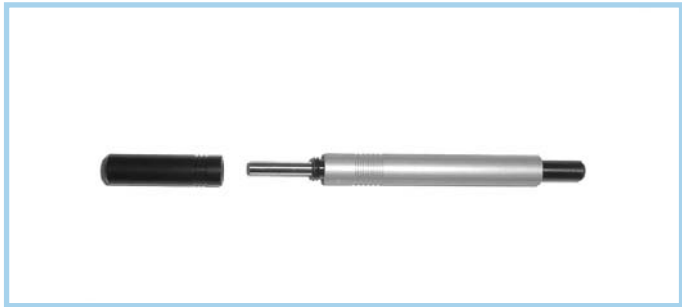

**DCC Extraction tools for coax contacts**

	Connector		Extractors
	Type	Coax Type	Part number
<b>2B</b>	810	C	DCC.91.384.5LA
<b>3B</b>	242/243	C	DCC.91.384.5LA
	822/844/846	C	DCC.91.384.5LA
	856/862	C	DCC.91.384.5LA
<b>4B</b>	244	C	DCC.91.384.5LA
	852/856/858/866	C	DCC.91.384.5LA
	879/885	C	DCC.91.384.5LA
<b>5B</b>	240	C	DCC.91.384.5LA
	260	D	DCB.91.685.BTN
	273/274	B	DCC.91.804.5LA
	850/856/857/864	B	DCC.91.804.5LA
	870/876/877	B	DCC.91.804.5LA
	892	D	DCB.91.685.BTN

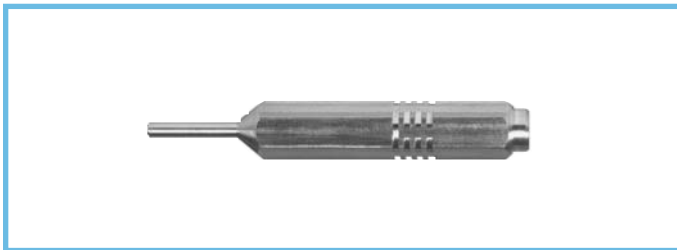

**DCK Retention testing tools for crimp contacts  
0.5-0.7-0.9 and 1.3 mm diameter**

Contact $\varnothing$ A	Test force (F)	Testing tool part number	
		For male contact	For female contact
0.5	8	DCK.91.050.8LRC	DCK.91.050.8LRM
0.7	14	DCK.91.071.4LRC	DCK.91.071.4LRM
0.9	14	DCK.91.091.4LRC	DCK.91.091.4LRM
1.3	25	DCK.91.132.5LRC	DCK.91.132.5LRM

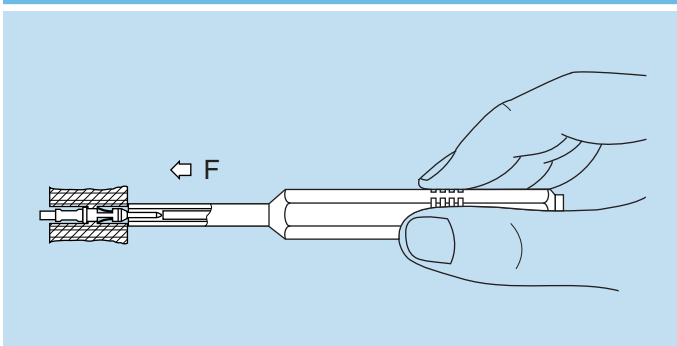

● Standard, typically 0-6 weeks delivery for quantities of 250 or less.  
 ○ Non-standard product, contact LEMO USA, typically 6-12 weeks delivery for quantities of 250 or less.  
 Non-standard product is defined as any product which contains one or more components which are not standard.

## Panel Cut-outs

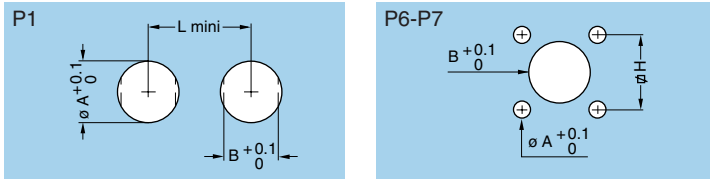

## K series

Series	P1			P6			P7		
	$\varnothing A$	B	L	$\varnothing A$	B	H	$\varnothing A$	B	H
0K	14.1	12.6	20.5	-	-	-	-	-	-
1K	16.1	14.6	22.5	-	-	-	-	-	-
2K	20.2	18.6	29.0	-	-	-	-	-	-
3K	24.2	22.6	35.5	3.5	22.6	20.6	3.5	23.1	23.0
4K	30.2	28.6	43.0	3.5	28.6	27.0	3.5	30.1	29.0
5K	45.2	42.6	57.0	4.5	42.6	38.0	4.5	45.1	44.0

## Cut-out types

Model	Type	Model	Type	Model	Type
EBG	P7	ENG	P1	PBG	P7 <sup>3)</sup>
EDG	P7 <sup>2)</sup>	EVG	P1	PEG	P1
EEG	P1	FAG	P1	PKG	P1
EGG	P1	FXG	P6	S●●	P1
EHG	P1	HEG	P1		
EMG	P1	HGG	P1		

## Mounting nut torque

Series	Torque (Nm)
0K	5
1K	7
2K	9
3K	12
4K	17
5K	22

1 N = 0.102 kg

**Note:** <sup>2)</sup> For this model dimension B = 18.1. <sup>3)</sup> For this model dimension B = 19.1.

## E series

Series	P1			P6		
	$\varnothing A$	B	L	$\varnothing A$	B	H
0E	14.1	12.6	20.5	-	-	-
1E	16.1	14.6	22.5	-	-	-
2E	20.2	18.6	29.0	2.9	19.1	11.8x20.4
3E	24.2	22.6	35.5	-	-	-
4E	30.2	28.6	43.0	-	-	-
5E	45.2	42.6	57.0	-	-	-
6E	55.3	52.1	68.0	-	-	-

## Cut-out types

Model	Type	Model	Type	Model	Type
EBR	P6	ERB	P1	PSA	P1
EEP	P1	ERC	P1	PSP	P1
EHP	P1	FAA	P1	SWH	P1
ERA	P1	HGP	P1		

## Mounting nut torque

Series	Torque (Nm)
0E	5
1E	7
2E	9
3E	12
4E	17
5E	22
6E	27

1 N = 0.102 kg

### PCB Drilling Pattern

#### Fixed receptacle with straight printed circuit contact (K series)

P15

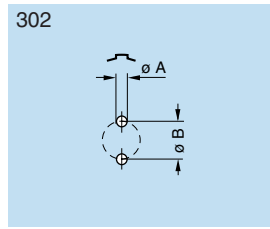

Series	Dimensions	
	A	B
0K	0.8	2.2
1K	0.8	2.8
2K	0.8	4.4

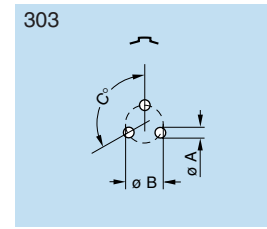

Series	Dimensions		
	A	B	C
0K	0.8	2.30	120°
1K	0.8	3.00	120°
2K	0.8	4.60	120°
3K	0.8	5.60	120°

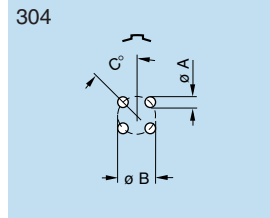

Series	Dimensions		
	A	B	C
0K	0.6	2.5	45°
1K	0.8	3.1	45°
2K	0.8	5.0	45°
3K	0.8	6.2	45°

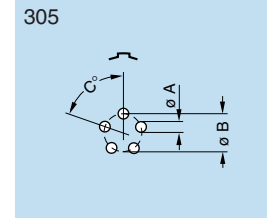

Series	Dimensions		
	A	B	C
0K	0.6	2.8	72°
1K	0.8	3.4	72°
2K	0.8	5.2	72°

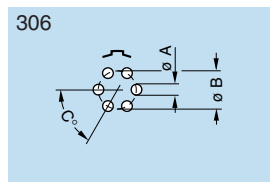

Series	Dimensions		
	A	B	C
0K	0.6	3.0	60°
1K	0.8	3.7	60°

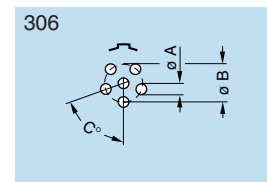

Series	Dimensions		
	A	B	C
2K	0.8	5.6	72°

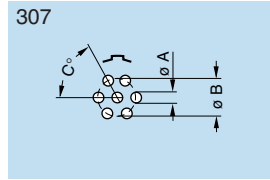

Series	Dimensions		
	A	B	C
0K	0.6	3.0	60°
1K	0.8	3.7	60°
2K	0.8	5.8	60°

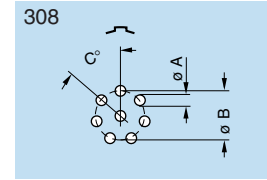

Series	Dimensions		
	A	B	C
1K	0.8	3.8	51°26'

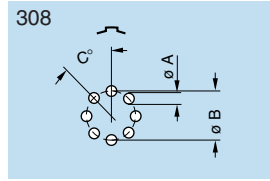

Series	Dimensions		
	A	B	C
2K	0.8	6.4	45°
3K	0.8	7.5	45°

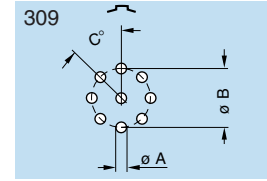

Series	Dimensions		
	A	B	C
3K	0.8	7.5	45°

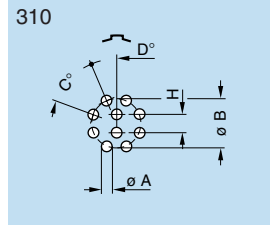

Series	Dimensions				
	A	B	C	D	H
1K	0.6	3.95	45°	22°30'	1.40
2K	0.8	6.20	45°	22°30'	2.15
3K	0.8	7.90	45°	22°30'	2.80

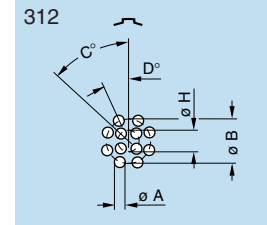

Series	Dimensions				
	A	B	C	D	H
2K	0.8	6.50	45°	22°30'	2.80
3K	0.8	8.20	45°	22°30'	3.40

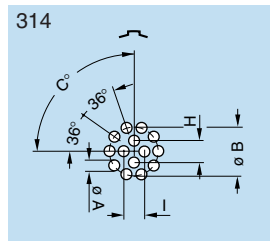

Series	Dimensions				
	A	B	C	H	I
1K	0.6	4.4	90°	1.90	1.80
2K	0.8	6.5	90°	2.65	2.65
3K	0.8	8.2	90°	3.40	3.40

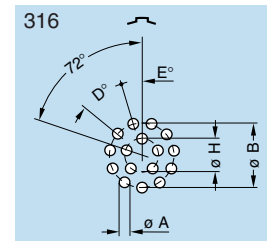

Series	Dimensions			
	A	B	D	H
1K	0.6	4.4	32°44'	2.00

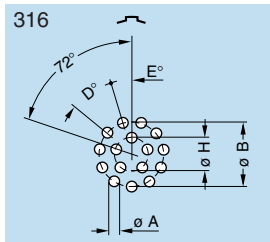

Series	Dimensions				
	A	B	D	E	H
2K	0.8	6.6	32°44'	16°22'	3.10
3K	0.8	8.4	32°44'	16°22'	3.86
4K	0.6	10.5	32°44'	16°22'	5.00

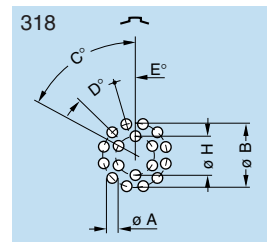

Series	Dimensions					
	A	B	C	D	E	H
2K	0.8	6.7	60°	30°	15°	3.50
3K	0.8	8.4	60°	30°	15°	4.34

Note: All views are from the side of the receptacle.

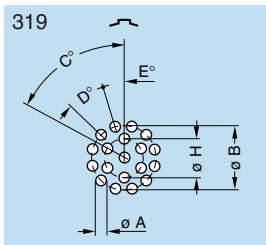

Series	Dimensions					
	A	B	C	D	E	H
2K	0.8	6.7	60°	30°	15°	3.5

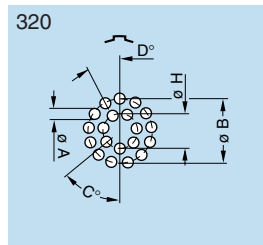

Series	Dimensions				
	A	B	C	D	H
3K	0.6	8.62	51°26'	27°42'	4.78
4K	0.6	11.00	51°26'	27°42'	6.00

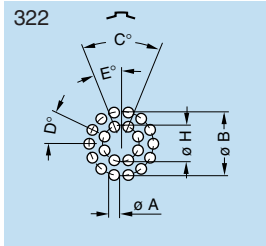

Series	Dimensions					
	A	B	C	D	E	H
3K	0.6	8.8	45°	25°43'	22°30'	5

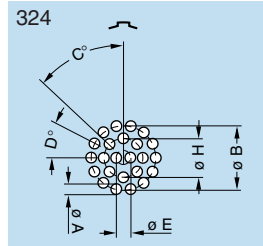

Series	Dimensions					
	A	B	C	D	E	H
3K	0.6	8.8	45°	25°43'	1.8	5.30
4K	0.6	11.1	45°	25°43'	2.2	6.65

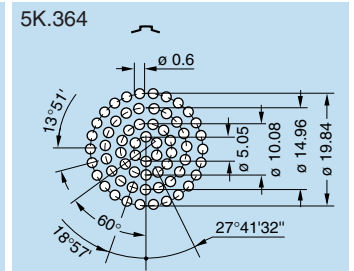
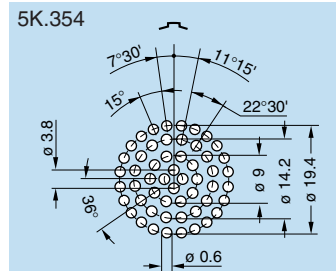
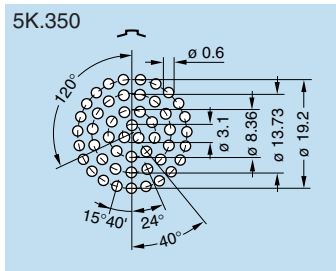
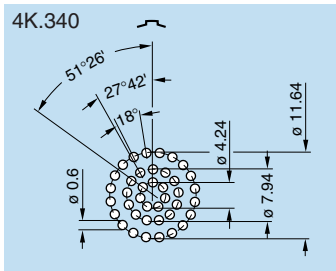
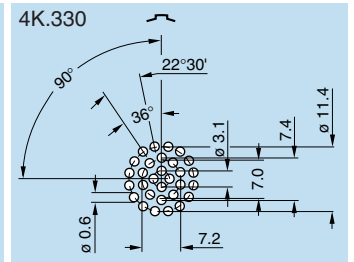
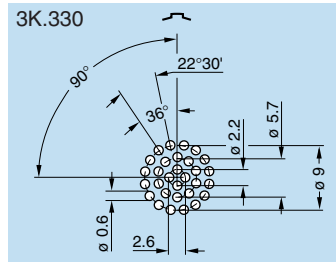
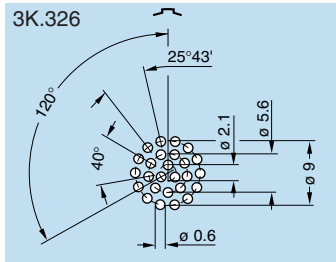
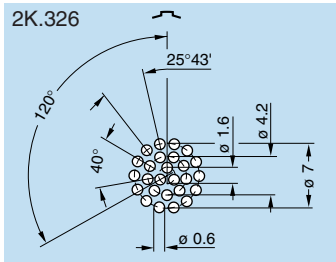

### Length of straight printed circuit contacts (for receptacle E●)

	Type	Dimensions	
		ø C	L
<b>0K</b>	302/303	0.7	3.0
	304/305	0.5	3.0
	306/307	0.5	3.0
<b>1K</b>	302/303/304/305	0.7	3.0
	306/307/308	0.7	3.0
	310/314/316	0.5	3.0
<b>2K</b>	302	0.7	3.0
	303/304/305/306/307/308/310	0.7	5.0
	312/314/316/318/319	0.7	6.0
	326	0.5	3.0
<b>3K</b>	303/304/308/309/310	0.7	3.0
	312/314/316/318	0.7	3.0
	320/322/324/326/328/330	0.5	4.5
<b>4K</b>	316/320	0.5	5.0
	324/330	0.5	5.0
	340	0.5	5.0
<b>5K</b>	350	0.5	5.0
	354	0.5	5.0
	364	0.5	5.0

Fixed receptacle with elbow printed circuit contact (K series) P17

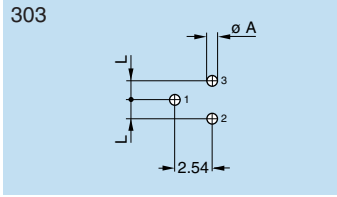
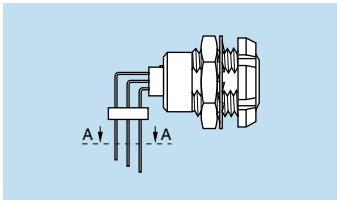

Series	Dim.	
	A	L
0K	0.7	1.27
1K	0.9	1.27
2K	0.9	2.54

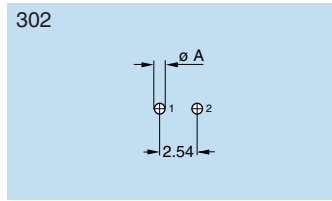

Series	Dim.
	A
0K	0.7
1K	0.9

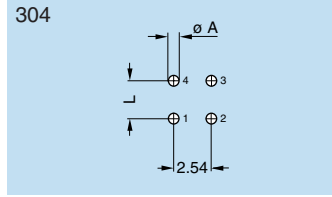

Series	Dim.	
	A	L
0K	0.7	2.54
1K	0.7	2.54
2K	0.9	3.50

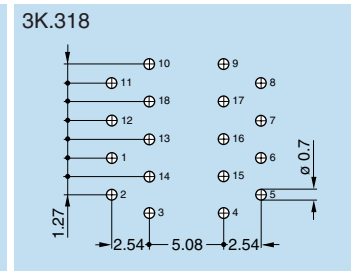
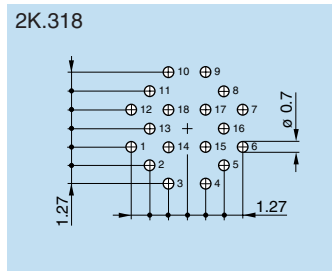
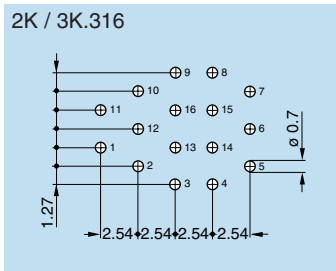
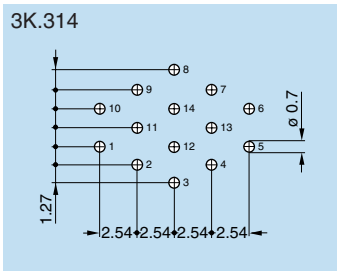
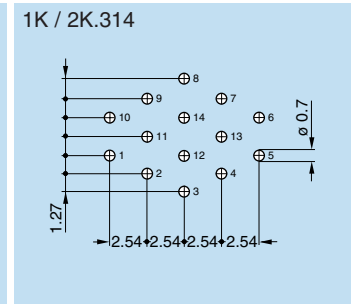
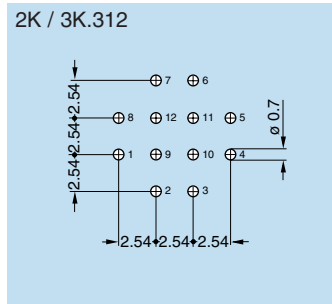
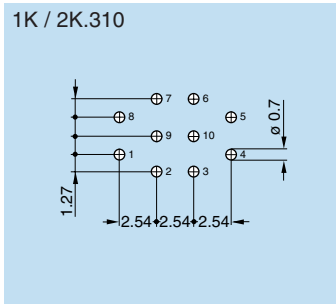
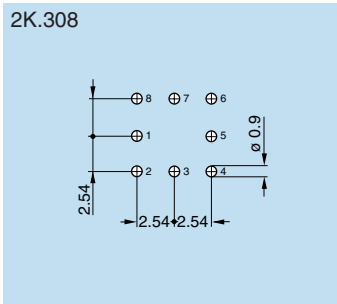
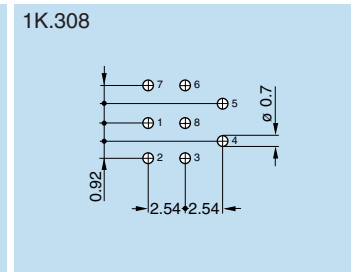
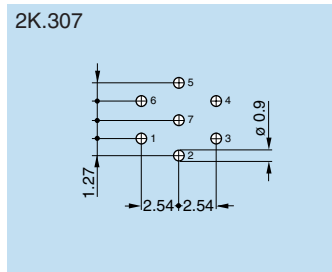
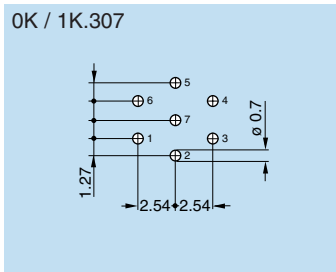
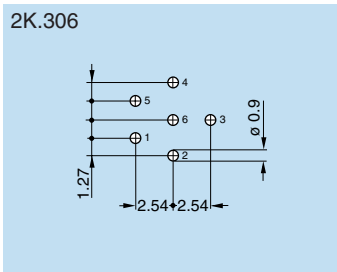
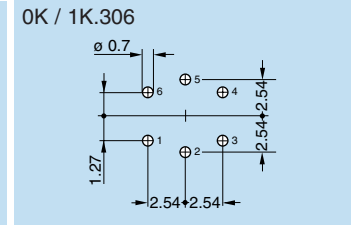
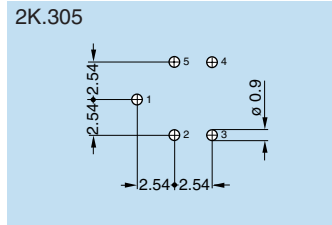
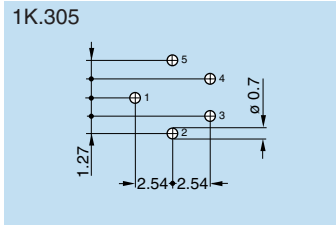
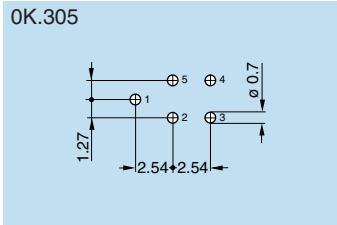

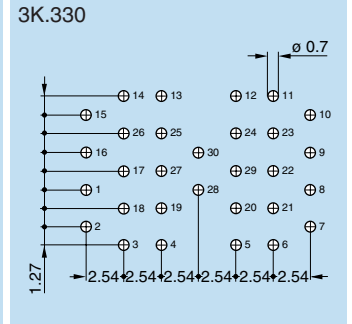
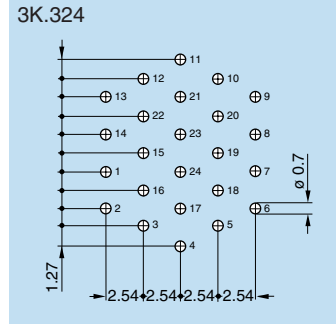
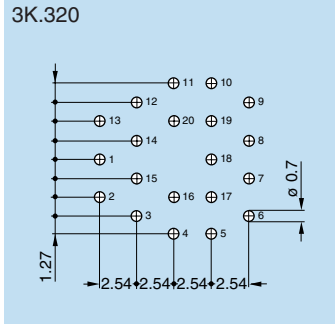
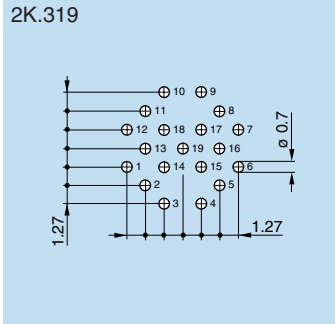

Fixed receptacle with straight printed circuit contact (E series) P21

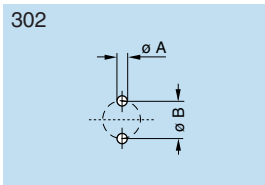

Series	Dimensions	
	A	B
0E	0.6	2.2
1E	0.8	3.0

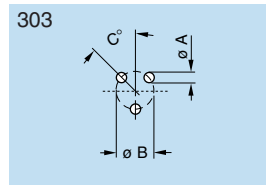

Series	Dimensions		
	A	B	C
0E	0.6	2.8	45°
1E	0.8	3.5	45°
2E	0.8	5.5	60°

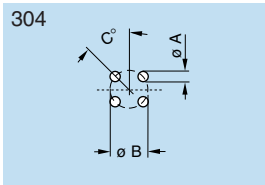

Series	Dimensions		
	A	B	C
0E	0.6	2.8	45°
1E	0.8	3.5	45°
2E	0.8	5.0	45°

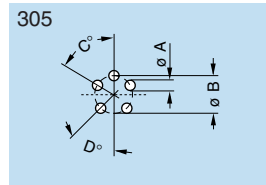

Series	Dimensions			
	A	B	C	D
1E	0.8	3.5	60°	45°
2E	0.8	5.5	60°	60°

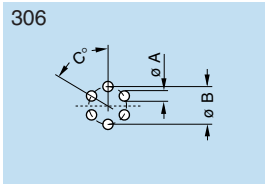

Series	Dimensions		
	A	B	C
1E	0.8	3.5	60°
2E	0.8	5.5	60°
3E	0.8	6.5	60°

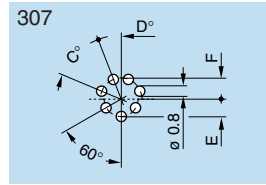

Series	Dimensions			
	C	D	E	F
2E	45°	22°30'	2.75	3.25
3E	45°	22°30'	3.25	3.90

Note: All views are from the side of the receptacle.

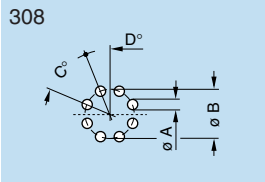

Series	Dimensions			
	A	B	C	D
2E	0.8	6.5	45°	22°30'
3E	0.8	7.8	45°	22°30'

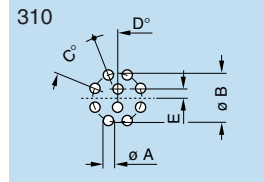

Series	Dimensions				
	A	B	C	D	E
2E	0.8	6.5	45°	22°30'	1.25
3E	0.8	7.8	45°	22°30'	1.50

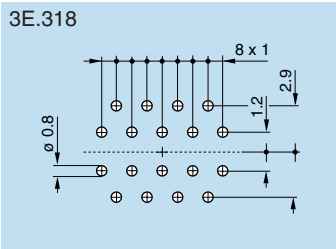
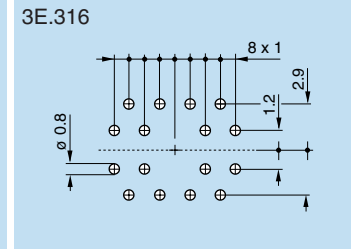
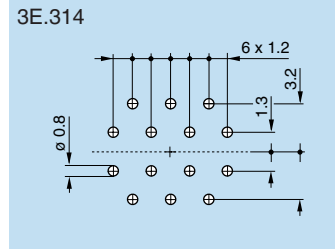
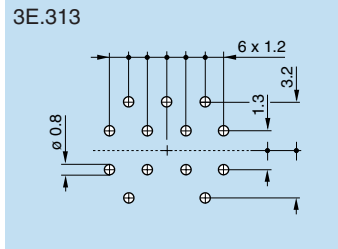
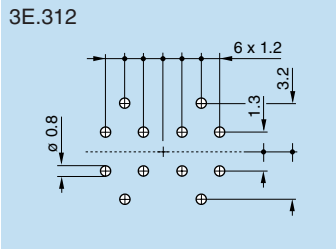

**Length of straight printed circuit contacts (for receptacle E●)**

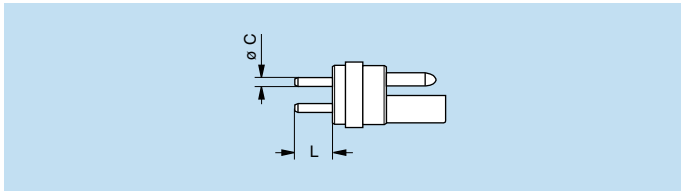

	Type	Dimensions	
		ø C	L
<b>0E</b>	302	0.7	3.0
	303	0.5	3.0
	304	0.5	3.0
<b>1E</b>	302	0.7	3.0
	303/304/305	0.7	3.0
	305/306	0.5	3.0
<b>2E</b>	303/304/305	0.8	3.0
	306/307	0.8	3.0
	307/308/310	0.7	3.0
<b>3E</b>	305/306/307/308/310	0.7	3.0
	312/313/314	0.7	3.0
	316/318	0.7	3.0

**Note:** This table does not apply for HGP and EHP receptacles and for FAA plugs.

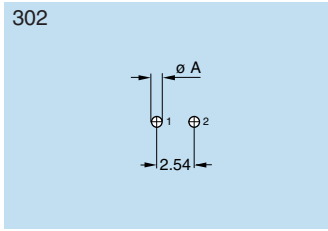
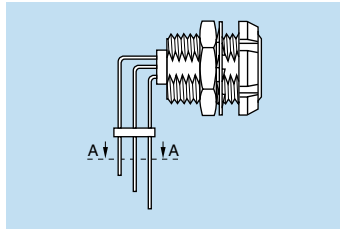
**Fixed receptacle with elbow printed circuit contact (E series) P24**

Series	Dim.
	A
0E	0.7
1E	0.9

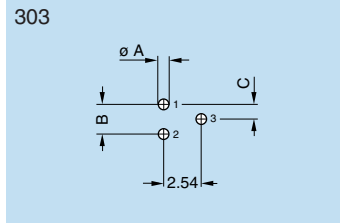

Series	Dimensions		
	A	B	C
0E	0.7	2.00	1.00
1E	0.7	2.48	1.24

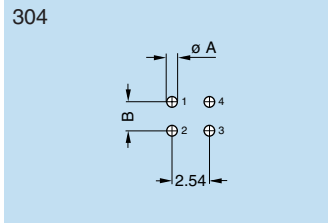

Series	Dimensions	
	A	B
0E	0.7	2.00
1E	0.7	3.50
2E	0.9	3.50

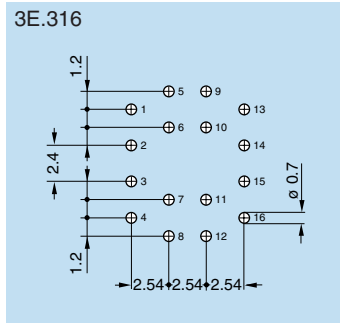
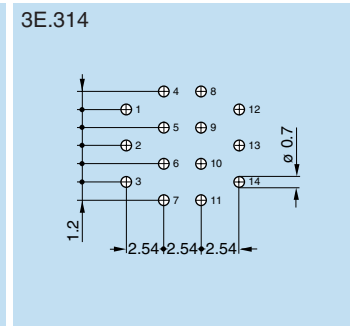
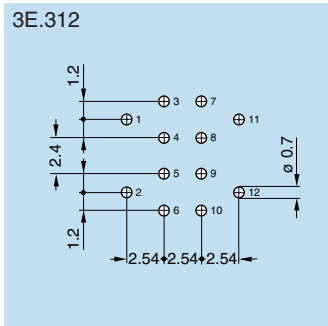
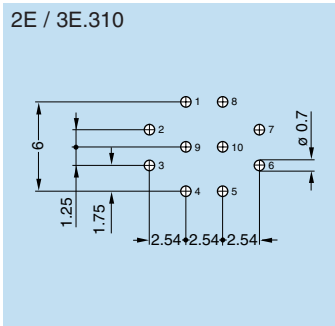
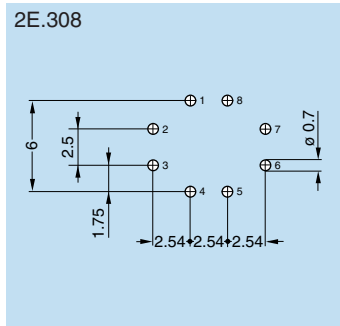
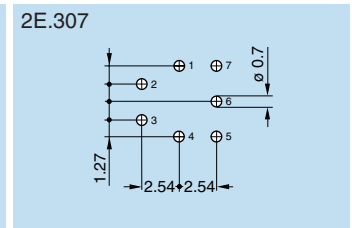
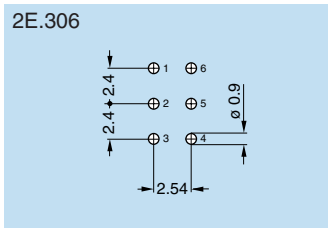
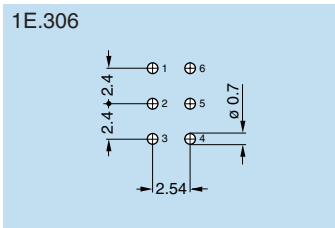
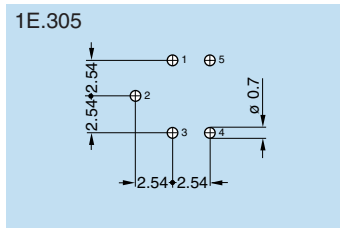



## Cable fixing

Cables are fixed into LEMO connectors with cable collet systems. These collets with latches have a design which is very similar to those used for tool machines. This solution guarantees excellent cable retention and ensures perfectly symmetrical deformation of the cable.

### Material and treatment

Component	Material (standard)	Surface treatment (µm)				
		Nickel		Gold		
		Cu	Ni	Cu	Ni	Au
Center piece	Brass (UNS C 38500)	0.5	3	–	–	–
Collet	Brass (UNS C 38500)	0.5	3	–	–	–
Crimp ferrule	Copper (UNS C 18700)	0.5	3	0.5	3	0.5
Reducer	Brass (UNS C 38500)	0.5	3	–	–	–
Reducing cone	Brass (UNS C 38500)	0.5	3	–	–	–
Grounding cone	Brass (UNS C 38500)	0.5	3	–	–	–
Metal washer	Brass (UNS C 38500)	0.5	3	–	–	–
Gasket	Silicone MQ/MVQ	–				
	FPM (Viton®)					

**Notes:**  
Standards for surface treatment are as follows:  
Nickel-plated: FS QQ-N-290A.

## Cable clamping

### Type C cable clamping (E series)

In standard watertight series (0E to 5E), C type clamping is completed by a flexible gasket ⑥ providing for watertightness on the cable end, by a metal washer ⑤ which prevents the gasket from rotating during the clamping; and by a grounding cone ⑦ which tightens the screen onto the grounding center-piece ③ or ④.

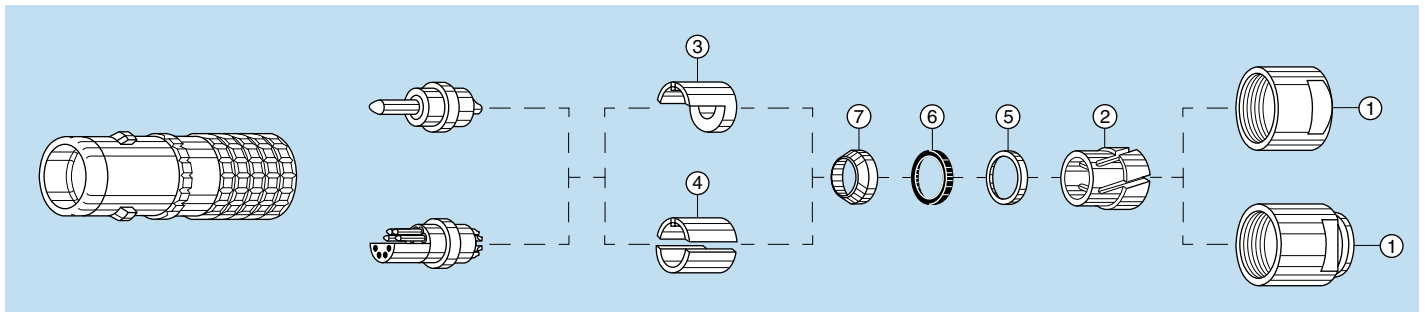

### Type K cable clamping (E series)

In standard watertight series (E series), the K type clamping type is completed by the flexible gasket ⑥ providing for watertightness on the cable end, by the metal washer ⑤ which prevents the gasket from rotating during the clamping ① and the grounding cone ⑦ of the next series size up which clamps the shield onto the longer split center-pieces ④.

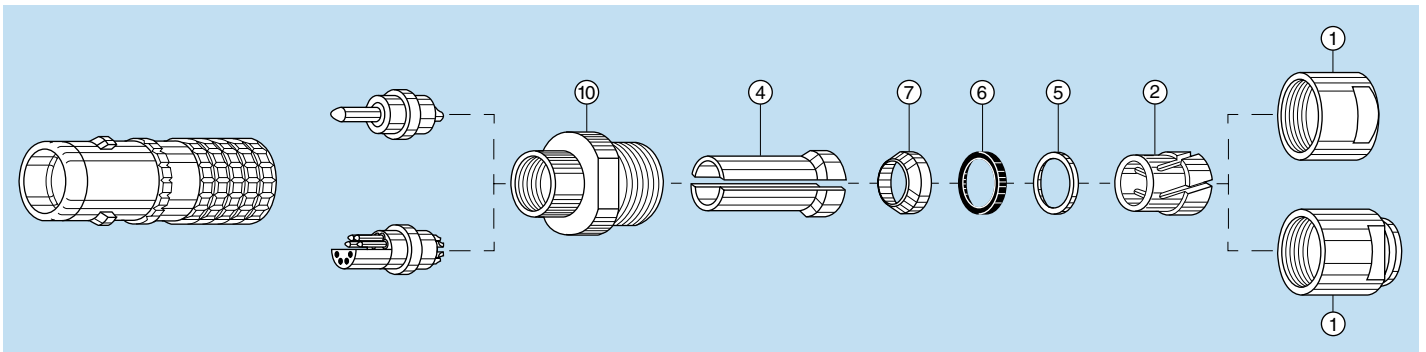

### Type C cable clamping (K series)

In the watertight series (K series), the C type clamping system is completed by a flexible gasket ⑥ providing for watertightness on the cable end, by a metal washer ⑤ preventing the gasket from rotating when the collet nut is clamped and a grounding cone ⑦ which clamps the shield onto the split insert carrier ④.

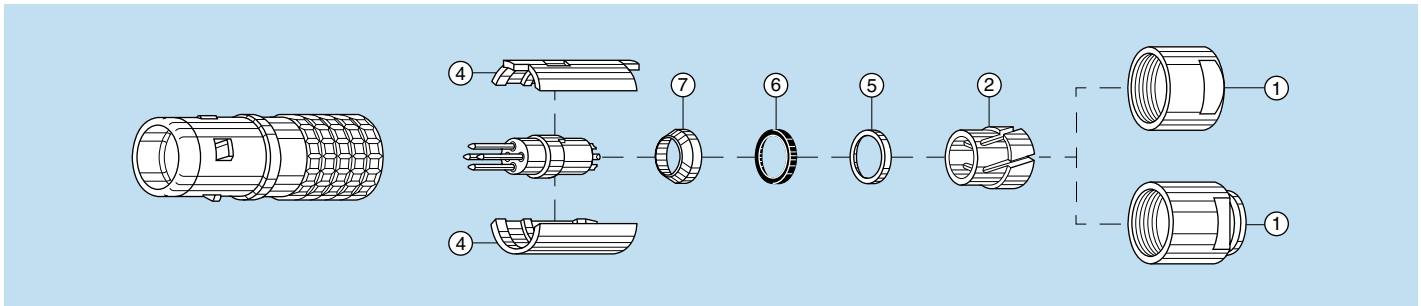

### Type K cable clamping (K series)

In the watertight keyed series (K series), the clamping system provides for using screened or unscreened cables, with a diameter larger than the maximum specified for each series. The shell is completed by an oversize collet housing ⑩. The collet ② and watertightness on the cable end are identical to type C cable clamping but are of the next series size up. The grounding cone ⑦ clamps the shield onto the longer split center-pieces ④.

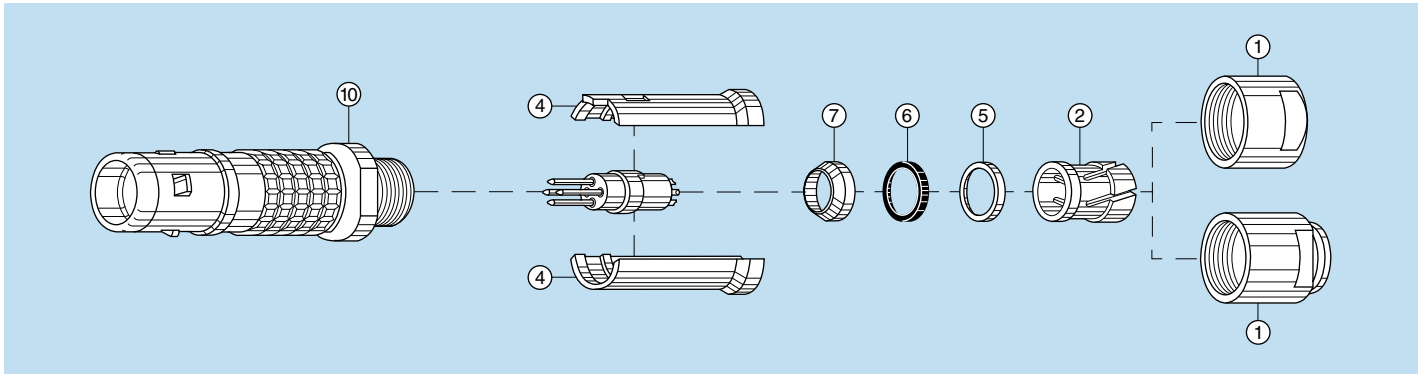

### Maximum metal collet nut tightening torque

#### Watertight series

	Series						
	0E	1E	2E	3E	4E	5E	6E
Torque (Nm)	0.7	0.8	2	3	5	8	12

#### Watertight keyed series

	Series					
	0K	1K	2K	3K	4K	5K
Torque (Nm)	0.7	0.8	2	3	5	8

1N = 0.102 kg

**Note:** See page 97 for correct torque procedure.

## ● Technical Tables

**Table of Wire Gauges**

AWG	Construction		ø wire max		Wire section	
	Strand nb	AWG/strand	(mm)	(in)	(mm <sup>2</sup> )	(sq in)
4	133	25	6.9596	0.274	21.5925	0.0335
6	133	27	5.5118	0.217	13.5885	0.0211
8	168	30	4.4450	0.175	8.5127	0.0132
8	133	29	4.3942	0.173	8.6053	0.0133
10	105	30	3.3020	0.13	5.3204	0.0082
10	37	26	2.9210	0.115	4.7397	0.0073
10	1	10	2.6162	0.103	5.2614	0.0082
12	65	30	2.5146	0.099	3.2936	0.0051
12	37	28	2.3114	0.091	2.9765	0.0046
12	19	25	2.3622	0.093	3.0847	0.0048
12 <sup>1)</sup>	7	20	2.5400	0.1	3.6321	0.0056
12	1	12	2.0828	0.082	3.3081	0.0051
14	41	30	2.0574	0.081	2.0775	0.0032
14	19	27	1.8542	0.073	1.9413	0.0030
14 <sup>1)</sup>	7	22	2.0828	0.082	2.2704	0.0035
14	1	14	1.6510	0.065	2.0820	0.0032
16 <sup>1)</sup>	65	34	1.5748	0.062	1.3072	0.0020
16	26	30	1.5748	0.062	1.3174	0.0020
16	19	29	1.4986	0.059	1.2293	0.0019
16 <sup>1)</sup>	7	24	1.5494	0.061	1.4330	0.0022
16	1	16	1.3208	0.052	1.3076	0.0020
18 <sup>1)</sup>	65	36	1.2700	0.05	0.8234	0.0013
18 <sup>1)</sup>	42	34	1.2700	0.05	0.8447	0.0013
18	19	30	1.3208	0.052	0.9627	0.0015
18	16	30	1.2954	0.051	0.8107	0.0013
18	7	26	1.2700	0.05	0.8967	0.0014
18	1	18	1.0414	0.041	0.8229	0.0013
20 <sup>1)</sup>	42	36	1.0160	0.04	0.5320	8.2 x 10 <sup>-4</sup>
20	19	32	1.0414	0.041	0.6162	0.0010
20	10	30	1.0160	0.04	0.5067	7.9 x 10 <sup>-4</sup>
20	7	28	0.9906	0.039	0.5631	8.7 x 10 <sup>-4</sup>
20	1	20	0.8382	0.033	0.5189	8.0 x 10 <sup>-4</sup>
22	19	34	0.8382	0.033	0.3821	5.9 x 10 <sup>-4</sup>
22	7	30	0.7874	0.031	0.3547	5.5 x 10 <sup>-4</sup>
22	1	22	0.6604	0.026	0.3243	5.0 x 10 <sup>-4</sup>
24 <sup>1)</sup>	42	40	0.6604	0.026	0.2045	3.2 x 10 <sup>-4</sup>
24	19	36	0.6858	0.027	0.2407	3.7 x 10 <sup>-4</sup>
24	7	32	0.6350	0.025	0.2270	3.5 x 10 <sup>-4</sup>
24	1	24	0.5588	0.022	0.2047	3.2 x 10 <sup>-4</sup>
26	19	38	0.5588	0.022	0.1540	2.4 x 10 <sup>-4</sup>
26	7	34	0.5080	0.02	0.1408	2.2 x 10 <sup>-4</sup>
26	1	26	0.4318	0.017	0.1281	2.0 x 10 <sup>-4</sup>
28 <sup>1)</sup>	19	40	0.4318	0.017	0.0925	1.4 x 10 <sup>-4</sup>
28	7	36	0.4064	0.016	0.0887	1.4 x 10 <sup>-4</sup>
28	1	28	0.3302	0.013	0.0804	1.2 x 10 <sup>-4</sup>
30	7	38	0.3302	0.013	0.0568	8.8 x 10 <sup>-5</sup>
30	1	30	0.2794	0.011	0.0507	7.9 x 10 <sup>-5</sup>
32	7	40	0.2794	0.011	0.0341	5.3 x 10 <sup>-5</sup>
32	1	32	0.2286	0.009	0.0324	5.0 x 10 <sup>-5</sup>
34	1	34	0.1693	0.007	0.0201	3.1 x 10 <sup>-5</sup>
36	1	36	0.127	0.005	0.0127	2.0 x 10 <sup>-5</sup>
38	1	38	0.1016	0.004	0.0081	1.3 x 10 <sup>-5</sup>
40	1	40	0.078	0.003	0.0049	7.5 x 10 <sup>-6</sup>

**Table of wire gauges according to IEC-228 standard**

Conductor no x Ø (mm)	Max Ø (mm)	Max Ø (in)	Section (mm <sup>2</sup> )	Section (sq in)
196 x 0.40	7.50	0.295	25.00	0.0387
7 x 2.14	6.10	0.240	25.00	0.0387
125 x 0.40	6.00	0.236	16.00	0.0248
7 x 1.72	4.90	0.192	16.00	0.0248
1 x 4.50	4.50	0.177	16.00	0.0248
80 x 0.40	4.70	0.155	10.00	0.0155
7 x 1.38	3.95	0.155	10.00	0.0155
1 x 3.60	3.60	0.141	10.00	0.0155
84 x 0.30	3.70	0.145	6.00	0.0093
7 x 1.50	3.15	0.124	6.00	0.0093
1 x 2.76	2.76	0.108	6.00	0.0093
56 x 0.30	2.80	0.110	4.00	0.0062
7 x 0.86	2.58	0.098	4.00	0.0062
1 x 2.25	2.25	0.082	4.00	0.0062
50 x 0.25	2.15	0.084	2.50	0.0038
7 x 0.68	2.04	0.080	2.50	0.0038
1 x 1.78	1.78	0.070	2.50	0.0038
30 x 0.25	1.60	0.062	1.50	0.0023
7 x 0.52	1.56	0.061	1.50	0.0023
1 x 1.14	1.40	0.055	1.50	0.0023
32 x 0.20	1.35	0.053	1.00	0.0015
7 x 0.43	1.29	0.050	1.00	0.0015
1 x 1.15	1.15	0.045	1.00	0.0015
42 x 0.15	1.20	0.047	0.75	0.0011
28 x 0.20	1.15	0.045	0.75	0.0011
1 x 1.0	1.00	0.039	0.75	0.0011
28 x 0.15	0.95	0.037	0.50	7.7 x 10 <sup>-4</sup>
16 x 0.20	0.90	0.035	0.50	7.7 x 10 <sup>-4</sup>
1 x 0.80	0.80	0.031	0.50	7.7 x 10 <sup>-4</sup>
7 x 0.25	0.75	0.029	0.34	5.2 x 10 <sup>-4</sup>
1 x 0.60	0.60	0.023	0.28	4.3 x 10 <sup>-4</sup>
14 x 0.15	0.75	0.029	0.25	3.8 x 10 <sup>-4</sup>
7 x 0.20	0.65	0.023	0.22	3.4 x 10 <sup>-4</sup>
18 x 0.10	0.50	0.019	0.14	2.1 x 10 <sup>-4</sup>
14 x 0.10	0.40	0.015	0.11	1.7 x 10 <sup>-4</sup>
21 x 0.07	0.40	0.015	0.09	1.3 x 10 <sup>-4</sup>
14 x 0.10	0.40	0.015	0.09	1.3 x 10 <sup>-4</sup>

**Note:** <sup>1)</sup> Not included in the standard

## • Conversion Tables — millimeters/inches

(mm)	(in)	(mm)	(in)	(mm)	(in)	(mm)	(in)	(mm)	(in)	(mm)	(in)
0.02	0.0007	1.37	0.0539	3.90	0.1535	8.90	0.3504	16.00	0.6299	29.50	1.1614
0.03	0.0011	1.40	0.0551	4.00	0.1575	9.00	0.3543	16.10	0.6338	30.00	1.1811
0.10	0.0039	1.50	0.0590	4.36	0.1716	9.40	0.3701	17.00	0.6693	30.80	1.2125
0.16	0.0062	1.52	0.0598	4.50	0.1771	9.50	0.3740	17.50	0.6889	31.00	1.2204
0.18	0.0071	1.60	0.0629	5.00	0.1968	9.60	0.3779	17.80	0.7007	31.80	1.2519
0.20	0.0078	1.70	0.0669	5.08	0.1999	9.70	0.3818	18.00	0.7086	32.00	1.2598
0.30	0.0118	1.71	0.0673	5.20	0.2047	10.00	0.3937	18.20	0.7165	33.00	1.2992
0.40	0.0157	1.80	0.0708	5.37	0.2114	10.30	0.4055	18.50	0.7283	33.50	1.3188
0.48	0.0188	2.00	0.0787	5.50	0.2165	10.40	0.4094	19.00	0.7480	34.00	1.3385
0.50	0.0196	2.10	0.0826	5.80	0.2283	10.50	0.4134	19.50	0.7677	34.50	1.3582
0.51	0.0201	2.20	0.0866	6.00	0.2362	10.70	0.4212	20.00	0.7874	35.70	1.4055
0.54	0.0212	2.42	0.0953	6.20	0.2441	10.80	0.4252	20.50	0.8071	36.00	1.4173
0.60	0.0236	2.50	0.0984	6.30	0.2480	11.00	0.4331	20.60	0.8110	40.00	1.5748
0.70	0.0275	2.60	0.1023	6.40	0.2519	11.50	0.4527	21.00	0.8267	41.00	1.6141
0.80	0.0315	2.70	0.1063	6.50	0.2559	11.70	0.4606	21.50	0.8464	42.00	1.6535
0.86	0.0338	2.80	0.1102	6.80	0.2677	12.00	0.4724	21.80	0.8582	43.00	1.6929
0.87	0.0342	2.95	0.1161	7.00	0.2755	12.60	0.4961	22.00	0.8661	45.00	1.7716
0.90	0.0354	3.00	0.1181	7.10	0.2795	12.90	0.5078	23.00	0.9055	45.50	1.7913
0.91	0.0358	3.05	0.1201	7.40	0.2913	13.00	0.5118	23.80	0.9370	46.50	1.8307
0.95	0.0374	3.10	0.1220	7.50	0.2952	13.70	0.5393	24.00	0.9448	50.00	1.9685
1.00	0.0393	3.20	0.1259	8.00	0.3149	14.00	0.5512	25.00	0.9842	60.00	2.3622
1.21	0.0476	3.30	0.1299	8.30	0.3267	14.30	0.5629	25.50	1.0039	65.00	2.5590
1.29	0.0507	3.50	0.1378	8.60	0.3385	14.50	0.5708	26.00	1.0236	70.00	2.7559
1.30	0.0512	3.78	0.1488	8.70	0.3425	15.00	0.5905	28.00	1.1023	78.00	3.0708
1.32	0.0519	3.80	0.1496	8.80	0.3464	15.50	0.6102	28.50	1.1220	150.00	5.9055

## ● Terms and Conditions

- 1. Acceptance:** THE ACCEPTANCE OF BUYER'S ORDER IS EXPRESSLY MADE CONDITIONAL ON BUYER'S ASSENT TO ALL OF THE TERMS AND CONDITIONS SET FORTH HEREIN, AND LEMO USA AGREES TO FURNISH THE MATERIALS, PRODUCTS AND SERVICES COVERED THEREBY ONLY UPON THESE TERMS AND CONDITIONS. These Terms & Conditions contain the entire agreement of the parties and there are no other promises or conditions in any other agreements whether oral or written. This document supersedes any prior written or oral agreements between the parties. The terms and conditions of this Agreement shall prevail, notwithstanding the fact Buyer's order may contain written, printed or stamped provisions or conditions inconsistent with and/or in addition to the written, printed or stamped provisions of this Agreement. Buyer shall contact LEMO USA within 10 days of receipt of LEMO USA Terms and Conditions, or prior to shipment of goods, whichever shall occur first, if any objection is raised. Failure of Buyer to timely object shall be deemed an acceptance by Buyer of LEMO USA's Terms and Conditions. If a timely objection is raised by the Buyer to the LEMO USA Terms and Conditions, the order(s) will not be entered until agreement in writing is reached. All orders are subject to acceptance by Lemo USA.
- 2. Pricing and payment:** All prices are F.O.B. Rohnert Park, California. Payment is due within 30 days of invoice date. All invoices are delinquent at 30 days past invoice date and will be subject to 1% per month finance charge. Overdue accounts may be placed on credit hold and shipments held. Buyer agrees to pay all reasonable collection charges, including attorney fees, in the event his account is delinquent more than 30 days. Buyer will be charged any direct additional cost to which Lemo USA is put by reason of any interruption of production due to Buyer's request, act or default.
- 3. Payment of Taxes:** In the event any sales tax, manufacturer's tax, or other tax is applicable to any shipment made by the Buyer on Buyer's order, such tax shall be added to the selling price and shall be paid by the Buyer. In the event Lemo USA is required to pay any such tax, Buyer shall reimburse Lemo USA therefore.
- 4. Title/Risk of Loss:** All sales are complete, and all Lemo USA's obligations hereunder are completed when Lemo USA delivers the items purchased, properly consigned, to a common carrier. Lemo USA's delivery to such carrier shall constitute delivery thereof to the Buyer, and all risk of loss or damage of goods in transit shall be borne by Buyer.
- 5. Security Interest:** Lemo USA shall retain a security interest in goods delivered hereunder, and in proceeds from the sale, exchange, collection, or disposition thereof, until Buyer has made payment in full for such goods. Buyer shall, upon request by Lemo USA, provide all information and signatures required by Lemo USA to perfect such security interest. Lemo USA reserves all rights granted to a secured creditor under the California Uniform Commercial Code, including the right to repossess upon default by Buyer. To simplify such repossession, Lemo USA may require the Buyer to assemble the collateral and make it available to Lemo USA at a place reasonably convenient to both parties and designated by Lemo USA.
- 6. Returns:** All NON-CANCELABLE/NON-RETURNABLE products shall not be returned. If Buyer intends to return standard product, a return authorization number is required prior to return shipment and the product may be subjected to a restocking fee. Lemo USA reserves the right not to issue a return authorization. Product must be returned (with shipping costs prepaid) in original packaging and in original condition as when purchased, undamaged, not reconfigured, not obsolete, fit for use, and shall not have been previously shipped from Lemo USA to Buyer or its customer more than one year prior to the date of return. Lemo USA reserves the right to not accept damaged product for credit, replacement, or substitution. If damaged product is accepted by Lemo USA for credit, and damage is caused by the negligence of the Buyer, the Buyer will pay all costs for refurbishment of damaged product. Discovery of product defect and return of product shall be made in the period of time following delivery as provided in the applicable sections of the Uniform Commercial Code. In the event of a return, Lemo USA shall have the right, in its sole discretion, to replace, substitute, or issue a credit to Buyer.
- 7. Buyer's Liability upon Default:** In the event Buyer cancels the contract embodied by Buyer's Purchase Order and this acceptance thereof, in whole or in part, or such contract is canceled by Lemo USA because of default by the Buyer, the Buyer shall pay Lemo USA by reason of such cancellation or default for reasonable direct costs sustained, including costs associated with completed units, shipped or unshipped, labor and materials on work in process, and raw materials on hand and/or specific to Buyer's Order and all other reasonable direct costs, for lead time specified in advance of requested date of cancellation, at the current price applicable to the total quantity ordered at the time of default. Notwithstanding the foregoing, if item or items ordered are NON-CANCELABLE/NON-RETURNABLE, the Buyer shall purchase 100% of quantity ordered.

In the event Lemo USA does not meet the confirmed delivery date agreed to with the Buyer as evidenced in writing, Lemo USA shall be allowed one opportunity to reschedule the delivery and Buyer shall not be entitled to cancel this contract for such reason. In the event Lemo USA does not meet said rescheduled delivery, Buyer may cancel this contract and not be in default hereunder, including the terms of this Section 7.
- 8. Indemnity:** Buyer hereby specifically agrees to defend Lemo USA, to save Lemo USA harmless and to indemnify Lemo USA against all claims for damage or profits and for all costs and attorney fees incurred by Lemo USA resulting from any suit or suits arising from alleged infringements of patents, design copyrights, or trademarks with respect to all goods manufactured, either in whole or in part, to Buyer's specifications. Lemo USA, at its expense, will defend Buyer and its customer against any reasonable and good faith claim based on an allegation that an unaltered LEMO USA product infringes a U.S. patent, trademark or copyright of another; provided however, that no such obligation shall apply to (i) any LEMO USA product manufactured to Buyer's specifications and/or designs or (ii) any product that has been modified, or altered by Buyer or a third party. Lemo USA shall pay any reasonable resulting costs (including reasonable attorney's fees), and damages finally awarded against Buyer or its customer that are attributable to such claim or will pay the part of any settlement that is attributable to such claim, provided that: (a) Buyer notifies Lemo USA promptly in writing of the claim; (b) Lemo USA is permitted to control the defense or settlement of the claim; and (c) Buyer and its customer cooperate reasonably in such defense or settlement. In the event any such product sold by LEMO USA is

held to constitute an infringement of any such US patent, trademark or copyright, and the use of such product by Buyer is enjoined, LEMO USA shall, at its own expense and option, either procure for Buyer the right to continue using said product, replace same with a non-infringing product, modify it so it becomes a non-infringing product, or have the product returned, and refund the purchase price to Buyer. In no event shall Lemo USA's total liability to Buyer under or as a result of compliance with the provisions of this paragraph exceed the aggregate sum paid by Buyer for the allegedly infringing product. The foregoing states the entire liability of LEMO USA for infringement by said products or by any part thereof, either alone or in combination with other devices or elements.

THE FOREGOING PROVISION IS STATED IN LIEU OF ANY OTHER EXPRESS, IMPLIED, OR STATUTORY WARRANTY AGAINST INFRINGEMENT AND SHALL BE THE SOLE AND EXCLUSIVE REMEDY FOR INFRINGEMENT OF ANY KIND.

- 9. Warranties:** Lemo USA warrants to Buyer that the goods will conform to the applicable drawings or design standards, and shall be free from defects in material and workmanship. The foregoing warranty shall apply for a period of one year from the date of shipment of product to Buyer. Lemo USA's sole responsibility shall be to replace any such nonconforming goods or repair such nonconforming goods without charge to Buyer. The express warranties set forth in this agreement are exclusive and are in lieu of all other express or implied warranties, but not limited to, warranties of merchantability and fitness for a particular purpose, and do not apply to products that have been modified, altered, misused, or damaged during shipment or by Buyer.  
EXCEPT AS EXPRESSLY SET FORTH IN THIS AGREEMENT, LEMO USA DISCLAIMS ALL EXPRESS AND IMPLIED WARRANTIES, INCLUDING WITHOUT LIMITATION, ANY IMPLIED WARRANTIES, WARRANTIES OF MERCHANTABILITY AND WARRANTIES OF FITNESS FOR A PARTICULAR PURPOSE OR USE.
- 10. License:** The submission of a quotation or order acknowledgment does not grant or imply a license under any patents now owned or controlled by Lemo USA, or which may become owned or controlled by Lemo USA.
- 11. Applicable Law:** This Agreement shall be subject to the applicable provisions of the Uniform Commercial Code, under the laws of the State of California.
- 12. Disputes and Resolution; Attorney's Fees:** The parties agree that any disputes or questions arising hereunder including the construction or application of these Terms and Conditions shall be settled in the State of California, according to the laws of the State of California. Any action based on this Agreement must be commenced within one (1) year after the cause of action arises. The parties hereto hereby consent to jurisdiction and venue in the Superior Court of Sonoma County, California, and in the Federal District Court for the Northern District of California, with respect to all disputes or disagreements under these Terms and Conditions and agree that any action with respect to any of the foregoing shall be brought and maintained only in such courts sitting in the Northern District of California or Sonoma County, as appropriate. In any court action at law or in equity, which is brought by one of the parties to enforce or interpret the provisions of these Terms and Conditions, the prevailing party will be entitled to costs and reasonable attorney's fees, in addition to any other relief to which that party may be entitled.
- 13. Confidentiality:** Both parties acknowledge that during the course of business, each may obtain confidential information regarding the other party's business. Both parties agree to treat all such information as confidential and to take all reasonable precautions against disclosure of such information to unauthorized third parties during and for five (5) years after the term of all orders. Upon request by an owner, all documents relating to the confidential information will be returned to such owner.
- 14. Assignment:** It is agreed by the parties that there will be no assignment or transfer of any order or any interest in any orders. Action by a party in violation of this provision will dismiss the other party from any further obligations arising from any orders.
- 15. Amendment:** These Terms & Conditions may be modified or amended if the amendment is made in writing and is signed by both parties.
- 16. Severability:** If any provision of these Terms & Conditions shall be held to be invalid or unenforceable for any reason, the remaining provisions shall continue to be valid and enforceable. If a court finds that any provision is invalid or unenforceable, but that by limiting such provision it would become valid and enforceable, then such provision shall be deemed to be written, construed and enforced as so limited.
- 17. Waiver of Contractual Right:** The failure of either party to enforce any provision of these Terms & Conditions shall not be construed as a waiver or limitation of that party's right to subsequently enforce and compel strict compliance with every provision of this Contract.
- 18. Limitation on Damages:** Buyer's consequential or incidental damages for any Lemo USA breach of the contract, except for Lemo USA's gross negligence or willful misconduct, will be limited to the purchase price. Subject to Section 8 hereof, Lemo USA will have no liability to Buyer for any damages, losses, liabilities, injuries, claims, demands or expenses arising out of or directly or indirectly connected with the use of the product. Lemo USA shall not be liable for any exemplary, indirect, incidental, or consequential damages sustained or incurred in connection with the use of the product regardless of the form of action, whether in contract, tort (including negligence) or strict liability.  
LEMO USA SHALL NOT BE LIABLE FOR ANY DAMAGES DUE TO CAUSES BEYOND THE REASONABLE CONTROL OF LEMO USA OR ATTRIBUTABLE TO ANY SERVICE, PRODUCTS, OR ACTIONS OF ANY PERSON OTHER THAN LEMO USA REGARDLESS OF THE FORM OF ACTION AND WHETHER OR NOT SUCH DAMAGES ARE FORESEEABLE.
- 19. Force Majeure:** NEITHER PARTY SHALL BE LIABLE IN ANY WAY TO THE OTHER PARTY FOR DELAYS, FAILURE IN PERFORMANCE, OR LOSS OR DAMAGE DUE TO FORCE MAJEURE CONDITIONS SUCH AS: FIRE; LIGHTENING; STRIKE; EMBARGO; EXPLOSION; POWER SURGE OR FAILURE; ACTS OF GOD; WAR; TERRORIST ATTACKS; LABOR DISPUTES; CIVIL DISTURBANCES; ACTS OF CIVIL OR MILITARY AUTHORITY; INABILITY TO SECURE MATERIALS, FUEL, PRODUCTS OR TRANSPORTATION FACILITIES; ACTS OR OMISSIONS OF SUPPLIERS, OR ANY OTHER CAUSES BEYOND ITS REASONABLE CONTROL, WHETHER OR NOT SIMILAR TO THE FOREGOING.

## ● Product Safety Notice

**PLEASE READ AND FOLLOW ALL INSTRUCTIONS CAREFULLY AND CONSULT ALL RELEVANT NATIONAL AND INTERNATIONAL SAFETY REGULATIONS FOR YOUR APPLICATION. IMPROPER HANDLING, CABLE ASSEMBLY, OR USE OF CONNECTORS CAN RESULT IN HAZARDOUS SITUATIONS.**

### 1. SHOCK AND FIRE HAZARD

Incorrect wiring, the use of damaged components, foreign objects (such as metal debris), and / or the presence of residue (such as cleaning fluids), can result in short circuits, overheating, and / or risk of electric shock. Mated components should never be disconnected while live as this may result in an exposed electric arc and local overheating, resulting in possible damage to components.

### 2. HANDLING

Connectors and their components should be visually inspected for damage prior to installation and assembly. Suspect components should be rejected or returned to the factory for verification. Connector assembly and installation should only be carried out by properly trained personnel. Proper tools must be used during installation and / or assembly in order to obtain safe and reliable performance.

### 3. USE

Connectors with exposed contacts should never be live (or on the current supply side of a circuit). Under general conditions voltages above 30 VAC and 42 VDC are considered hazardous and proper measures should be taken to eliminate all risk of transmission of such voltages to any exposed metal part of the connector.

### 4. TEST AND OPERATING VOLTAGES

The maximum admissible operating voltage depends upon the national or international standards in force for the application in question. Air and creepage distances impact the operating voltage; reference values are indicated in the catalog however these may be influenced by PC board design and / or wiring harnesses. The test voltage indicated in the catalog is 75% of the mean breakdown voltage; the test is applied at 500 V/s and the test duration is 1 minute.

### 5. CE MARKING

CE Marking is applied to a complete product or device, and implies that the device complies with one or several European safety directives. CE Marking can NOT be applied to electromechanical components such as connectors.

### 6. PRODUCT IMPROVEMENTS

The LEMO Group reserves the right to modify and improve to our products or specifications without providing prior notification.

## ● Design Engineering Services

DATE: \_\_\_\_\_

LEMO creates custom designs to fit your unique application, ranging from connector to multi-component assemblies.

- **Custom Connectors** - Precision designs tested to your specifications
- **Cable Assembly** - Electronic and hybrid fiber optic cable assemblies to meet a wide variety of demanding applications
- **Cable Assembly Integration** - Consultation on routing of cable and connections within your product
- **Rapid Prototyping** - Onsite engineering and rapid prototyping capabilities to assist in the high demands of product development
- **Pro/ENGINEER®** 3D solid CAD models available

## Manufacturing Services

Outsource your manufacturing challenges. LEMO's capable engineering staff can create solutions for your cable assembly or component sub-assembly designs.

- **Cable Assembly** - Expertise in both electronic and fiber optic connector termination
- **Overmolding Design and Manufacture** - Custom overmold designs to enhance aesthetics while providing durability and strength
- **Sub-Assembly Build** - Combine our connectors and cable assemblies with your sub-assemblies to provide a tested and proven module

**I am interested in:**

- Design Engineering Services**
- Manufacturing Services**

**Please send me information on:**

---

---

---

---

---

---

---

---

---

---

Name	Rep. Name
Title	Telephone <span style="float: right;">Fax</span>
Company Name	Email
Street	
City	State <span style="float: right;">Zip</span>

Please detach and fax directly to LEMO at (707) 578-0869,  
or mail to LEMO USA, Attn.: Engineering, P.O. Box 2408, Rohnert Park, CA 94927-2408



# ● Cable Assembly Request Form

DATE: \_\_\_\_\_  BID  BUY  BUDGETARY

Name		Rep. Name	
Title		Telephone	Fax
Company Name		Email	
Street			
City	State	Zip	

ASSEMBLY QUANTITIES \_\_\_\_\_ LENGTH (TIP TO TIP) \_\_\_\_\_

CONNECTORS: \_\_\_\_\_

STRAIN RELIEF:  NO  YES IF YES, SPECIFY COLOR \_\_\_\_\_

OVERMOLDING:  NO  YES IF YES, PROVIDE DETAILED DRAWING AND MATERIAL SPECIFICATION \_\_\_\_\_

END #1 \_\_\_\_\_ END #2 \_\_\_\_\_

END #1 \_\_\_\_\_ END #2 \_\_\_\_\_

WHAT IS YOUR APPLICATION? \_\_\_\_\_ LENGTH (TIP TO TIP) \_\_\_\_\_

CUSTOMER SUPPLIED CABLE:  NO  YES IF YES, PLEASE SUPPLY CABLE SPECIFICATIONS \_\_\_\_\_

IF NO, DO YOU REQUIRE CABLE SELECTION ASSISTANCE?  NO  YES

IF NO, PLEASE PROVIDE PART NUMBER AND MANUFACTURER OF CABLE YOU WISH LEMO TO USE: \_\_\_\_\_

IF YES, PLEASE FILL IN THE INFORMATION BELOW:

NUMBER OF CONDUCTORS \_\_\_\_\_ TWISTED PAIRS:  NO  YES WIRE GAUGE: \_\_\_\_\_

SHIELDING:  NO  YES IF YES, PLEASE SPECIFY TYPE: \_\_\_\_\_

JACKET MATERIALS / JACKET COLOR (GREY IS STANDARD)

OPERATING ENVIRONMENT: VOLTAGE: \_\_\_\_\_ CURRENT: \_\_\_\_\_ TEMPERATURE RANGE: HIGH: \_\_\_\_\_ LOW: \_\_\_\_\_

UNDERWATER: DEPTH: \_\_\_\_\_

CLEAN  WASH DOWN OR SPLASH  SALT WATER SPRAY  DIRT  OTHER: \_\_\_\_\_

STERILIZATION:  NO  YES IF YES, NUMBER OF CYCLES: \_\_\_\_\_

AUTOCLAVING: \_\_\_\_\_  RADIATION: TYPE: \_\_\_\_\_

FLUIDS: TYPE: \_\_\_\_\_  CHEMICALS: TYPE: \_\_\_\_\_

GASES: TYPE: \_\_\_\_\_

PROTOTYPE ORDER QUANTITY: \_\_\_\_\_ EXPECTED DELIVERY DATE: \_\_\_\_\_

PRODUCTION ORDER QUANTITY: \_\_\_\_\_ EXPECTED DELIVERY DATE: \_\_\_\_\_

EAU: \_\_\_\_\_ TARGET PRICING \$ \_\_\_\_\_

PLEASE ATTACHED DRAWING IF POSSIBLE

Please detach and fax directly to LEMO at (707) 578-0869, or mail to LEMO USA, Attn.: Cable Assembly, P.O. Box 2408, Rohnert Park, CA 94927-2408

# ● Custom Connector Design Request Form

DATE: \_\_\_\_\_

Name		Rep. Name	
Title	Telephone	Fax	Email
Company Name			
Street			
City	State	Zip	

### Customer Profile

APPLICATION DESCRIPTION: \_\_\_\_\_

 BUDGET: IS THE PROJECT FUNDED?  YES  NO EXPLANATION: \_\_\_\_\_

 SECOND SOURCE: DOES THE CUSTOMER REQUIRE A SECOND SOURCE?  YES  NO

WHY IS LEMO BEING CONSIDERED? DOES LEMO HAVE A COMPETITIVE ADVANTAGE ACKNOWLEDGED BY THE CUSTOMER? \_\_\_\_\_

### Connector Description

SHELL CONFIGURATION: \_\_\_\_\_ NUMBER OF CONTACTS: \_\_\_\_\_

 SERIES/SIZE: \_\_\_\_\_ IS BEND RELIEF REQUIRED:  YES  NO

 TYPE OF TERMINATION PREFERRED:  SOLDER  CRIMP  PRINTED CIRCUIT  OTHER

JACKET O.D. OF THE CABLE AND TYPE OF MATERIAL: \_\_\_\_\_

 CONDUCTOR DIAMETER OF THE CABLE (AWG) \_\_\_\_\_  IF COAX, CABLE TYPE \_\_\_\_\_

### Electrical Characteristics

WORKING VOLTAGE: \_\_\_\_\_ PEAK: \_\_\_\_\_ CURRENT (AMPS) \_\_\_\_\_

IMPEDANCE (OHMS): \_\_\_\_\_ MAXIMUM VSWR AT MAX. FREQUENCY: \_\_\_\_\_

WORKING FREQUENCY: NORMAL \_\_\_\_\_ MAXIMUM \_\_\_\_\_

NUMBER OF INSERTION CYCLES (1 CYCLE = 1 INSERTION = 1 WITHDRAWAL): \_\_\_\_\_

### Environment

OPERATING TEMPERATURES: \_\_\_\_\_

 ENVIRONMENT:  CLEAN  WASH DOWN OR SPLASH  SALT WATER SPRAY  UNDERWATER

 DIRT  FLUIDS \_\_\_\_\_  DUST  GASES \_\_\_\_\_

 CHEMICALS  IP RATING \_\_\_\_\_  EXPLOSIVES  RADIATION

 STERILIZATION:  YES  NO METHOD \_\_\_\_\_ CYCLES \_\_\_\_\_ TEMP \_\_\_\_\_

### Purchase Projections

PROTOTYPE ORDER QUANTITY (3 OR LESS): \_\_\_\_\_ EXPECTED DELIVERY DATE: \_\_\_\_\_

PRODUCTION ORDER QUANTITY: \_\_\_\_\_ EXPECTED DELIVERY DATE: \_\_\_\_\_

PREPRODUCTION ORDER QUANTITY: \_\_\_\_\_ EXPECTED DELIVERY DATE: \_\_\_\_\_

EXPECTED QUANTITY INVOLVED EACH YEAR: \_\_\_\_\_ TARGET PRICING: \$ \_\_\_\_\_

 APPLICABLE STANDARDS:  UL  IEC  OTHER \_\_\_\_\_

PLEASE ATTACH DRAWING IF POSSIBLE OR NECESSARY

Please detach and fax directly to LEMO at (707) 578-0869, or mail to LEMO USA, Attn.: Engineering, P.O. Box 2408, Rohnert Park, CA 94927-2408



Located 50 miles north of San Francisco, LEMO USA offers a nationwide network of product specialists, sales consultants and distributors, who work closely with customers in offering sales and technical support.



635 Park Court, Rohnert Park, CA 94928  
P.O. Box 2408, Rohnert Park, CA 94927-2408  
**(800) 444-5366** • (707) 578-8811 • fax: (707) 578-0869  
**[www.lemousa.com](http://www.lemousa.com)** • e-mail: [info@lemousa.com](mailto:info@lemousa.com)

